

# GENERATORI DI ARIA CALDA *FORCED AIR SPACE HEATERS*



**MADE IN ITALY**

CATALOGO/LISTINO 2022 *CATALOG/PRICE LIST 2022*

**BM2** **BIEMMEDUE**  
**ARCOTHERM**

Fondata nel 1979, la **Biemmedue S.p.A.** è leader mondiale nella progettazione e produzione di generatori d'aria calda, deumidificatori professionali e macchine per la pulizia industriale.

L'azienda ha sede a Cherasco, in Piemonte, alle porte delle Langhe, non lontana da Torino e da Milano. La struttura produttiva copre un'area di 35.000 m<sup>2</sup> ed è suddivisa in due stabilimenti: la sede legale dove vengono progettati e realizzati i generatori d'aria calda a marchio **Arcotherm** ed i deumidificatori professionali a marchio **Arcodry**; il nuovo stabilimento inaugurato ad inizio 2018 dedicato alla progettazione ed alla produzione di macchine professionali per la pulizia a marchio **Arcomat**: idropulitrici, aspiratori, spazzatrici e monospazzole.

**Biemmedue** vanta diverse eccellenze, tra le quali:

- una tecnologia progettuale d'avanguardia, grazie ai sistemi CAD-CAM e ad un laboratorio prove dotato di sofisticate apparecchiature di test e di collaudo;
- un sistema di produzione, 100% made in Italy, fortemente verticalizzato che consente un monitoraggio di tutte le fasi del processo produttivo ed una ampia flessibilità di adattamento alle esigenze del cliente;
- assemblaggio dei prodotti mediante attrezzature all'avanguardia e moderne linee di montaggio automatizzate;
- i magazzini dei prodotti finiti, della componentistica e dei ricambi sono sempre riforniti garantendo la spedizione entro le ventiquattro ore dall'ordine;

● le più rigorose procedure di controllo di qualità e di rispondenza ai più severi standard internazionali di rendimento e di sicurezza.

**Biemmedue** può contare sulla professionalità di 150 collaboratori che compongono una struttura efficiente, preparata e sempre disponibile; il servizio commerciale affianca il cliente accogliendone esigenze e stimoli, proponendo soluzioni specifiche e d'avanguardia per i più diversi settori di utenza. Il servizio formazione ed assistenza tecnica, grazie alla sua ottima organizzazione interna ed alla sua elevata competenza, assicura al cliente una linea diretta per la formazione, l'installazione, la messa in servizio e la manutenzione dei prodotti. Ecco le ragioni che oggi fanno di **Biemmedue** una delle più importanti realtà produttive a livello mondiale nell'ambito delle apparecchiature al servizio delle aziende.

## L'AZIENDA



**Biemmedue S.p.A.**, founded in 1979, is the world's leading designer and manufacturer of space heaters, professional dehumidifiers, and industrial cleaning machines. We are based in Cherasco (northwest Italy, not far from Turin and Milan), and our factory, that covers an area of 35.000 m<sup>2</sup>, is divided between two plants: the headquarters where we design and manufacture **Arcotherm** space heaters and **Arcodry** professional dehumidifiers; The new plant opened beginning of 2018 and dedicated to the design and production of professional cleaning machines branded **Arcomat**: high pressure cleaners, vacuum cleaners, wet vacuum cleaners and single disc floor machines.

**Biemmedue** has many strong points, including:

- cutting-edge design technology utilising CAD-CAM systems and a laboratory with sophisticated test and inspection equipment;

- a highly verticalised production system, 100% Made in Italy, with constant monitoring of all steps of the production process and rapid, flexible adaptation to our customers' needs;

- products are manufactured and assembled with state of art equipment and automated assembly lines;

- warehouses fully stocked with finished products, components, and spare parts to guarantee shipments within 24 hours after receipt of orders;

- strict Quality Control procedures and conformity to stringent international production and safety standards.

**Biemmedue** has an efficient and helpful team of 150 professionals. Our Customer Service Department

works with customers, listens to their needs and input, and proposes targeted, state-of-the-art solutions for every sector. Our well-organized and expert Training and Technical Service Department provides customers a direct line for training, installation, commissioning, and maintenance of all products.

This is why **Biemmedue** is one of the world's largest manufacturers of these types of equipment.



COMPANY WITH  
QUALITY SYSTEM  
CERTIFIED BY DNV GL  
= ISO 9001 =



# THE COMPANY



Dal 1979 la Biemmedue soddisfa le esigenze dei propri clienti da più di 40 anni, progettando e costruendo prodotti che si sono evoluti con il passare degli anni, che continua a sviluppare con l'obiettivo di poter anticipare i bisogni dei propri clienti.

E' con il bagaglio di esperienza di tutti questi anni, modelli, studi, prove, errori e successi che oggi stiamo tracciando e seguendo la strada del futuro, per continuare con la stessa determinazione per raggiungere nuovi traguardi.



Costituzione della BIEMMEDUE S.p.A. (Bonfante Elio, Marengo Franco, Marengo Luciano), per la commercializzazione in Piemonte, Liguria e Valle D'Aosta della gamma ARCOM SPA (Generatori d'aria calda e idropulitrici).

*Foundation of BIEMMEDUE S.p.A. (Bonfante Elio, Marengo Franco, Marengo Luciano), a company distributing the ARCOM SPA range (Hot air generators and Hydro cleaners) in Piedmont, Liguria and Valle D'Aosta.*



Partnership con il Sig. Charles Wittmer ed internazionalizzazione delle vendite dei prodotti BIEMMEDUE a livello mondiale.

*Partnership with Mr. Charles Wittmer and internationalization of sales of BIEMMEDUE products worldwide.*



Alla linea di generatori d'aria calda Arcotherm viene affiancata la seconda linea Oklima.

*The second Oklima line join the Arcotherm hot air generator line.*

1979

1982

1984

1992

1994

2007



A seguito della chiusura della ARCOM S.p.A., BIEMMEDUE S.p.A. rileva le attrezzature ed inizia la produzione di generatori d'aria calda e Idropulitrici per il mercato locale ed italiano.

*BIEMMEDUE S.p.A. takes over the ARCOM SPA legacy and starts the production of Hot air generators and Hydro cleaners for the local and Italian market.*



Al generatore d'aria calda ed all'idropulitrice si affianca la produzione del DEUMIDIFICATORE PROFESSIONALE.

*The production of the PROFESSIONAL DEHUMIDIFIER is added to hot air generator and pressure washer.*



Ottenimento certificazione qualità UNI EN ISO 9001, ora UNI EN ISO 9001: 2015.

*Achievement of the certification UNI EN ISO 9001, now UNI EN ISO 9001: 2015.*



Founded in 1979, *Biemmedue* has been meeting the needs of its customers for 40 years, designing and building machines that have evolved over the years and which continues to do so today to keep pace with the times but not only: "we like to think to be able to anticipate the needs of our customers".

Via our experience over all these years with models, studies, trials, mistakes and successes that today we are designing the path of the future, to continue with the same spirit that has pushed us here.



Acquisizione del 100 % delle azioni *Biemmedue S.p.A.* da parte dei fratelli Mariano e Pier Antonio Costamagna.

Acquisition of the 100% of shares of *Biemmedue S.p.A.* by the brothers Mariano and Pier Antonio Costamagna.



Ottenimento dell'omologazione CSA (Canadian Standard Association) per l'esportazione dei generatori d'aria calda nel mercato del Nord America (Stati Uniti e Canada).

Obtaining of the CSA (Canadian Standard Association) approval for the export of hot air generators in the North American market (United States and Canada).

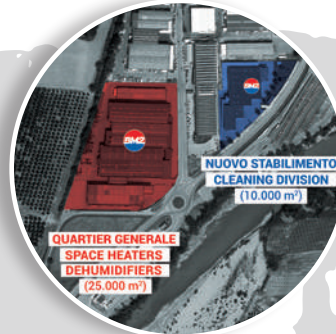

Concentramento delle attività del ramo cleaning in unico, moderno e dedicato stabilimento in Cherasco, di fronte alla sede legale dell'azienda.

Moving of the whole cleaning division to a dedicated facility in Cherasco: modern, bigger and in front of the company's head quarters.



Acquisizione ramo d'azienda *Batclean S.r.l.* di Summaga di Portogruaro (VE), azienda produttrice di motospazzatrici.

Acquisition of *Batclean S.r.l.* company in of Summaga di Portogruaro (VE), a company producing motorized sweepers.



Acquisizione ramo d'azienda *Solo S.r.l.* di Codogno (LO), azienda produttrice di Aspiratori e monospazzole.

Acquisition of the *Solo S.r.l.* in Codogno (LO), a company producing commercial vacuum cleaners, industrial vacuum cleaners and single disc brush units.



Alla gamma di prodotti per la pulizia professionale si aggiunge la linea di pulitori a vapore dedicati alla sanificazione di superfici e ambienti.

In the professional cleaning range is added the line of steam cleaners dedicated to the sanitization of surfaces and environments.



# NOVITÀ 2022

## 2022 NEWS



### EKT

GENERATORI MOBILI D'ARIA CALDA A CORRENTE ELETTRICA CON VENTILATORE CENTRIFUGO  
ELECTRICAL MOBILE SPACE HEATERS WITH CENTRIFUGAL FAN

(page 63)



### GA/N

GENERATORI D'ARIA CALDA PENSILI IN BASSA PRESSIONE A COMBUSTIONE DIRETTA  
DIRECT COMBUSTION LOW PRESSURE SUSPENDED SPACE HEATERS

(page 87)



### CH

GENERATORI D'ARIA CALDA PENSILI A GRANDE PORTATA A COMBUSTIONE INDIRETTA  
INDIRECT COMBUSTION HEAVY DUTY SUSPENDED SPACE HEATERS

(page 97)



### CONFORT

GENERATORI D'ARIA CALDA FISSI INDUSTRIALI PLUG & PLAY A COMBUSTIONE INDIRETTA  
INDIRECT COMBUSTION INDUSTRIAL PLUG AND PLAY CABINET SPACE HEATERS

(page 121)



### SP

GENERATORI D'ARIA CALDA FISSI INDUSTRIALI A COMBUSTIONE INDIRETTA  
INDIRECT COMBUSTION INDUSTRIAL CABINET SPACE HEATERS

(page 125)



# SOMMARIO SUMMARY

<b>EDILIZIA ED EVENTI</b>				
<i>CONSTRUCTION AND EVENTS</i>		9		
FIRE		13		
GE		17		
EC		21		
PHOEN		25		
JUMBO		29		
TITAN		37		
SCUDO		45		
FT		51		
GP		53		
GW		57		
EK		59		
<b>NEW</b> EKT		63		
<b>AGRICOLTURA E ALLEVAMENTO</b>				
<i>AGRICULTURE AND BREEDING</i>		67		
GE/S		71		
EC/S		75		
GE AGRI		79		
GA		83		
<b>NEW</b> GA/N		87		
			BH	91
			<b>NEW</b> CH	97
			FARM	101
			EK P	111
			FJ	113
			<b>INDUSTRIA</b>	
			<i>INDUSTRY</i>	
				115
			VERTIGO	117
			<b>NEW</b> CONFORT	121
			<b>NEW</b> SP	125
			ATTREZZATURE	
			<i>EQUIPMENT</i>	132
			PESI E DIMENSIONI	
			<i>WEIGHTS AND DIMENSIONS</i>	133
			FORMULE ED EQUIVALENZE	
			<i>FORMULAS AND EQUIVALENCES</i>	136
			CONDIZIONI DI VENDITA	
			<i>TERMS OF SALE</i>	137





# EDILIZIA ED EVENTI *CONSTRUCTION AND EVENTS*



## EDILIZIA ED EVENTI - CONSTRUCTION AND EVENTS

Fanno parte di questa famiglia i generatori mobili di aria calda rispondenti alla logica del riscaldamento mobile o temporaneo di emergenza, in ambiente interno ed esterno, dal prezzo relativamente contenuto e soprattutto esenti da necessità di installazioni. Grazie alla maneggevolezza, alla mobilità, alla robustezza, all'affidabilità ed alla flessibilità, trovano applicazione principalmente nei settori edilizia (cantieri, costruzioni, ecc...) e nelle strutture o ricoveri temporanei (tendoni, tensostrutture, ecc...). Si tratta generalmente di prodotti monocombustibili (gasolio o gas), dotati di ruote e/o maniglie di movimentazione, equipaggiabili con accessori vari che ne consentono diverse applicazioni, a seconda delle esigenze della clientela. Fanno parte di questa famiglia:

*This family includes mobile space heaters for temporary mobile or emergency heating, outdoors or indoors, at a relatively low price and, most important, without need of installation.*

*These heaters are easy to handle and move, sturdy, reliable, and flexible, making them perfect for the building sector (yards, construction projects, etc.) and in temporary structures or shelters (tents, tensile structures, etc.).*

*These are generally single-fuel-fired products (diesel or gas) with wheels and/or handles, and fit with accessories for a wide variety of applications.*

*This family includes:*



**FIRE:** alimentati a gasolio, con bruciatore integrato, ad irraggiamento: la caratteristica che contraddistingue questi modelli è l'assenza di movimentazione d'aria; la fiamma che viene generata dal bruciatore scalda la parabola la quale, grazie alle alte temperature, ferma e brucia tutti i residui della combustione, garantendo una combustione pulita ed un rendimento del 100%. Trovano impiego per il riscaldamento localizzato di ambienti particolarmente grandi (magazzini, capannoni, cantieri, spazi aperti, ecc...) oppure dove è opportuno evitare di aver polveri sospese nell'ambiente.

***FIRE:** diesel-fuelled, with integrated burner, heating by radiation. These models are characterised by the absence of moving air: the flame generated by the burner heats the parabola, which, thanks to its high temperature, stops and burns all combustion residues, guaranteeing clean combustion and 100% efficiency. They are used for heating very large spaces (warehouses, industrial sheds, yards, open spaces, etc.) or where suspended dust particles must be avoided.*



**GE:** alimentati a gasolio, con bruciatore integrato, a combustione diretta: i residui della combustione vengono espulsi con l'aria calda prodotta dal generatore e contribuiscono al suo riscaldamento, per questo motivo hanno un rendimento del 100% ovvero trasformano tutta la potenza bruciata in potenza termica resa. Sono i più economici, anche per quel che riguarda l'esercizio ma per contro possono essere impiegati solamente in locali areati.

***GE:** diesel-fuelled, with integrated burner, heating by direct combustion. Combustion residues are expelled with the hot air produced by the generator and contribute to its heating, making these heaters 100% efficient, i.e., they transform all of nominal input power into generated thermal power. They are the most economical models, including with regard to operation. On the other hand, they can be used only in ventilated rooms.*



**EC e PHOEN:** alimentati a gasolio, con bruciatore integrato (EC) e separato (PHOEN) dal ventilatore, a combustione indiretta: impiegano uno scambiatore di calore che permette l'evacuazione dei fumi attraverso un camino collegabile con l'esterno; possono quindi essere collocati all'interno di locali chiusi, per contro hanno un costo più elevato ed un rendimento intorno al 90%, dovendosi calcolare, in riduzione, la quantità di calore evacuata attraverso il camino.

**JUMBO:** a combustione indiretta, macchine di grande dimensione per ambienti più voluminosi, possono montare indifferentemente un bruciatore esterno a gasolio, GPL o metano. Equipaggiate con ventilatore assiale rispondente alle normative ERP 2015 sono un ottimo compromesso per rendimento (93%), silenziosità e prevalenza, caratteristica consigliabile in particolare per montaggi ove sono previste canalizzazioni.

**TITAN:** a combustione indiretta, macchine di grandi dimensioni per ambienti più voluminosi possono montare indifferentemente un bruciatore esterno a gasolio, gpl o metano. Equipaggiate con ventilatore centrifugo che, oltre ad essere molto silenzioso, garantisce elevata prevalenza (500 Pa), caratteristica consigliabile in particolare per installazioni ove è prevista lunga canalizzazione e/o ripresa aria. La camera di combustione a 5 giri di fumi garantisce inoltre un rendimento termico del 96%.

**SCUDO:** di derivazione dal modello TITAN, robusto e potente generatore d'aria calda, particolarmente indicato per il riscaldamento e l'asciugatura di grandi spazi, tensostrutture come cantieri edili, luoghi di lavoro ma anche zone residenziali

**EC e PHOEN:** diesel-fuelled, with integrated (EC) and separate (PHOEN) burner from ventilator. Heating by indirect combustion with a heat exchanger that expels fumes through a chimney connected to the outside. Therefore, they can be operated in closed rooms. On the other hand, they have higher cost and efficiency of about 90% due to the heat lost through the chimney.

**JUMBO:** indirect fired heater with considerable size, ideal for large buildings. It features external burner that can be chosen between gas (GPL or natural gas) and diesel. Equipped with axial fan in compliance with ERP 2015, it is a good compromise for efficiency (93%), low noise and static pressure, characteristic particularly usefully where ducts are needed.

**TITAN:** indirect fired heater with considerable size, ideal for large buildings. It features external burner that can be chosen between gas (GPL or natural gas) and diesel. Equipped with centrifugal fan that guarantees low noise operations as well as high static pressure (500 Pa), that makes it suitable in installation with long ducts. The combustion chamber features 5-loop smoke technology to ensure 96% thermal efficiency.

**SCUDO:** derivation from the TITAN model, strong and sturdy space heater, particularly suitable for the heating and drying of large spaces, technical structures such as construction sites, work places, and also residential areas



**GP:** alimentati a GPL in alta pressione (1,5 bar), con bruciatore integrato ed a combustione diretta. Sono realizzati in due versioni: ad accensione manuale (M) tramite piezoelettrico ed ad accensione automatica (A) grazie ad una apparecchiatura di controllo fiamma, che consente il collegamento di un termostato per controllare accensione e spegnimento. Per la loro alimentazione vengono in genere collegati alle bombole di GPL, il che li rende maneggevoli e molto economici.

**GP:** powered by high-pressure (1.5 bar) LPG, with integrated burner and direct combustion. There are two versions: with flame manual start (M) by piezoelectric, and automatic start (A) with a control unit that connects to a thermostat that controls starting and stopping. They are usually connected to LPG tanks, which makes them easy to handle and very economical.



**GW:** alimentati a GPL in alta pressione (1,5 bar), con bruciatore integrato ed a combustione diretta. Autonomi, non necessitano di alimentazione elettrica, l'accensione è manuale tramite piezoelettrico. Per la loro alimentazione vengono in genere collegati alle bombole di GPL, il che li rende maneggevoli e molto economici.

**GW:** powered by high-pressure (1.5 bar) LPG, with integrated burner and direct combustion. Stand-alone, no electricity required, with flame manual start by piezoelectric. They are usually connected to LPG tanks, which makes them easy to handle and very economical.



**EK:** di struttura simile ai modelli GP, sono alimentati a corrente elettrica. Infatti, in sostituzione del bruciatore vi sono delle resistenze elettriche le quali garantiscono il riscaldamento dell'aria, che viene convogliata mediante il ventilatore. Questa caratteristica li rende idonei all'impiego in qualsiasi condizione, anche nei locali chiusi, per contro la potenza termica è limitata e vengono preferibilmente impiegati ove l'energia elettrica è disponibile a basso costo.

**EK:** these have a structure similar to GP models, but run on electricity. Instead of the burner they have electrical resistors that heat the air conveyed by the fan. This characteristic makes them suitable under all conditions, even in closed rooms. On the other hand, they have limited thermal power and are generally used where low-cost electrical energy is available.



**EKT:** alimentati a corrente elettrica, sono studiati per applicazioni in tensostrutture, tende, emergenze ed applicazione mobili dove non è consentito l'utilizzo di combustibili fossili. Sono equipaggiati con ventilatore centrifugo che, oltre ad essere molto silenzioso, garantisce elevata prevalenza.

**EKT:** powered by electricity, these models are designed for applications in structures, tents, emergencies and mobile applications where the use of fossil fuels is not allowed. EKT are equipped with centrifugal fan that guarantees low noise operations as well as high static pressure.



# FIRE



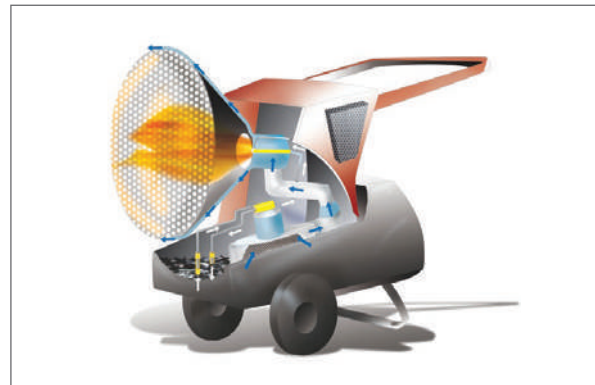

GENERATORI MOBILI D'ARIA CALDA A RAGGI INFRAROSSI, COMBUSTIONE DIRETTA  
*DIRECT COMBUSTION INFRARED MOBILE SPACE HEATERS*

## FIRE - GENERATORI MOBILI D'ARIA CALDA A RAGGI INFRAROSSI, COMBUSTIONE DIRETTA

- Flusso diretto di calore per irraggiamento senza movimentazione d'aria
- Basso livello di rumore
- Bruciatore BM2 dedicato con componentistica UE standard (vedere pag. 28)
- Pompa gasolio ad ingranaggi
- Controllo elettronico di fiamma con fotoresistenza
- Possibilità di interfaccia con termostato, umidostato o timer
- Cavo alimentazione elettrica (1,5 m) con spina
- Camera di combustione in acciaio inox AISI 430
- Raffreddamento involucro esterno mediante aria forzata su tutta la superficie del cono
- Post-ventilazione temporizzata di raffreddamento della camera di combustione
- Tubi alimentazione gasolio in gomma resistente agli idrocarburi con rivestimento metallico
- Serbatoio in rotazionale polietilene antiurto
- Tappo chiusura serbatoio gasolio a vite con valvola di sfogo
- Tappo di scarico gasolio
- Orientabilità del cono diffusore con bloccaggio
- Ganci di sollevamento
- *Direct heat flow by radiation with no movement of air*
- *Low noise level*
- *Dedicated BM2 burner with standard UE components (see page 28)*
- *Geared fuel pump*
- *Electronic flame control with photo resistance sensor*
- *Possibility of interface with thermostat, humidistat or timer*
- *Power cord (1,5 m) with plug*
- *AISI 430 stainless steel combustion chamber*
- *Outer cover cooled by forced air over the complete surface of the cone*
- *Timed post ventilation to cool the combustion chamber*
- *Fuel pipes in hydrocarbon-resistant rubber with a metal casing*
- *Shockproof rotomoulding polythene fuel tank*
- *Screw-on fuel cap*
- *Fuel drain plug*
- *Possibility of directing the cone and blocking it in position*
- *Lifting hooks*



ACCESSORI A RICHIESTA / ACCESSORIES ON DEMAND

<b>INDICATORE DI LIVELLO</b> <b>FUEL LEVEL GAUGE</b>	<b>TERMOSTATO AMBIENTE +5/+30°C</b> <b>CON CAVO L=10 m E SPINA 90°</b> <b>ROOM THERMOSTAT +5/+30°C</b> <b>CABLE 10 m, PLUG 90°</b>	<b>TERMOSTATO</b> <b>AGRICOLTURA/CANTIERE -5/+50°C</b> <b>CON CAVO L=10 m E SPINA 90°</b> <b>HEAVY DUTY THERMOSTAT -5/+50°C</b> <b>CABLE 10 m, PLUG 90°</b>
		
<b>Cod. 02AC583</b> <b>€50,90</b>	<b>Cod. 02AC581</b> <b>€49,30</b>	<b>Cod. 02AC582</b> <b>€98,80</b>
<b>FILTRO GASOLIO RISCALDANTE</b> <b>PRE-HEATED FUEL FILTER</b>		
		
<b>Mod. FIRE 45</b> <b>Cod. 02AC548</b> <b>€175,50</b>		

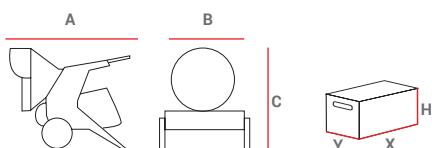

MOD	PESI E DIMENSIONI MACCHINA WEIGHTS AND DIMENSIONS MACHINE				IMBALLO PACKAGING			
	A	B	C	Netto/Net	X	Y	H	Lordo/Gross
	[mm]	[mm]	[mm]	[kg]	[mm]	[mm]	[mm]	[kg]
FIRE 25	895	532	808	42	740	570	705	47
FIRE 45 1S	1.410	712	1.053	73	1.027	705	1.036	91

		FIRE 25	FIRE 45 (1 SPEED)
codice - code		06VA113	06VA101
potenza term. nominale 2° stadio - rated heat power 2nd stage	Hs [kW] Hs [kcal/h - BTU/h]	25,8 22.185 - 88.294	45,5 39.130 - 155.737
rendimento - heat efficiency	[%]	100	100
consumo - fuel consumption	1s stage [kg/h]	2,04	3,6
potenza elettrica - power consumption 230 V	[W]	140	370
alimentazione elettrica - electrical power	[V - ph - Hz]	230 - 1 - 50	230 - 1 - 50
capacità serbatoio - tank capacity	[l]	43	65
quantità per pallet - pallet quantities	[pz - pcs]	6	1
<b>PREZZO - PRICE</b>	<b>EURO</b>	<b>1.467,00</b>	<b>2.780,00</b>

### Innovazione Biemmedue soggetta a brevetto

L'innovazione del generatore BM2 è l'adozione di un bruciatore dedicato BM2, in sostituzione di quelli tradizionali che si trovano in commercio (Ecoflam, Riello, Lamborghini, ecc.). Questo consente di eliminare il cono refrattario in fibra di ceramica presente nelle camere di combustione di macchine analoghe e di sostituirlo con un cono multistrato composto da 3 coni concentrici il cui raffreddamento è assicurato da un ventilatore che provvede, nel contempo, a generare il flusso d'aria necessario per la combustione del gasolio e la conseguente fiamma. Grazie a questa innovazione si eliminano i problemi tecnici dovuti alla fragilità e friabilità della fibra in ceramica e si ottiene un maggior raffreddamento dell'involucro esterno del generatore.



### *Biemmedue innovation patent pending*

*The innovation of the BM2 generator lies in the adoption of a specific BM2 burner, that substitutes the traditional ones on the market (Ecoflam, Riello, Lamborghini, etc.). This allows the elimination of the ceramic fibre refractory cone to be found in the combustion chamber of similar machines and to replace it with a multilayer cone consisting of three concentric cones which are cooled by a fan that, at the same time, generates the flow of air necessary for the fuel combustion and the flame. Thanks to this innovation technical problems related to the fragility and brittleness of ceramic fibre have been eliminated. Furthermore there is an improvement in the cooling of the outer covering of the generator.*

### Protezione inferiore estensibile per evitare surriscaldamento della pavimentazione

*Lower protection sliding shield to avoid the floor overheating*



### Orientabilità del cono diffusore *Tilting infrared cylinder*







# GE

GENERATORI MOBILI D'ARIA CALDA A COMBUSTIONE DIRETTA  
*DIRECT COMBUSTION MOBILE SPACE HEATERS*

## GE - GENERATORI MOBILI D'ARIA CALDA A COMBUSTIONE DIRETTA

- Bruciatore di gasolio integrato
- Controllo elettronico di fiamma
- Termostato di surriscaldamento
- Presa per collegamento a termostato, umidostato o timer (GE 36, GE 46, GE 65, GE 105)
- Cavo alimentazione elettrica (1,5 m) con spina
- Camera di combustione in acciaio inox AISI 430
- Post-ventilazione temporizzata di raffreddamento della camera di combustione
- Tubi alimentazione gasolio in gomma resistente agli idrocarburi con rivestimento in maglia rinforzante tessile (GE 20, GE 36, GE 46), metallica (GE 65, GE 105)
- Serbatoio in polietilene antiurto (GE 20, GE 36, GE 46), in acciaio (GE 65, GE 105)
- Tappo chiusura serbatoio a baionetta
- Tappo di scarico combustibile dal serbatoio
- *Build-in diesel burner*
- *Electronic flame-control*
- *Safety thermostat*
- *Set to be connected to a thermostat or a humidistat or a timer (GE 36, GE 46, GE 65, GE 105)*
- *Power cord (1,5 m) with plug*
- *AISI 430 stainless steel combustion chamber*
- *Automatic post ventilation of unit*
- *Fuel feed lines in hydrocarbon resistant rubber, whit a reinforced textile (GE 20, GE 36, GE 46) or metal sheath (GE 65, GE 105)*
- *Tank in tough hydrocarbon resistant polythene (GE 20, GE 36, GE 46) or steel (GE 65, GE 105)*
- *Bayonet-type fuel tank cap*
- *Fuel tank drain plug*

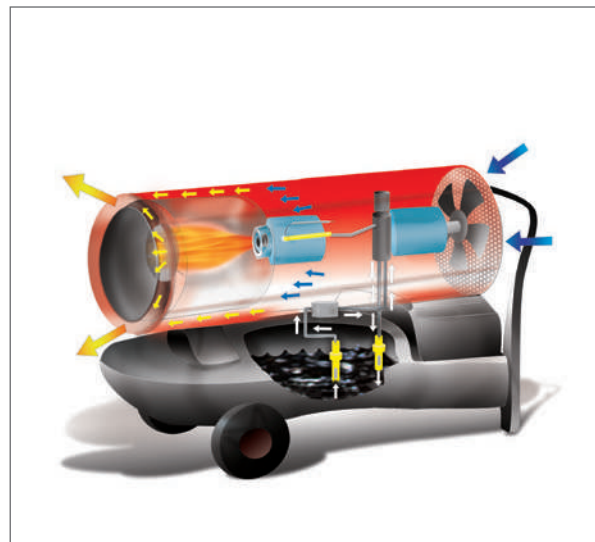

ACCESSORI A RICHIESTA / ACCESSORIES ON DEMAND

<p>INDICATORE DI LIVELLO FUEL LEVEL GAUGE</p>	<p>FILTRO RIEMPIMENTO SERBATOIO GASOLIO FUEL TANK FILLER FILTER</p>	<p>STAFFE SOLLEVAMENTO (4 PEZZI) LIFTING BRACKETS (4 PIECES)</p>
		
<p>Mod. GE 36 - GE 46 - GE 65 - GE 105 Cod. 02AC508 €50,90</p>	<p>Mod. GE 36 - GE 46 - GE 65 - GE 105 Cod. 02AC556 €16,80</p>	<p>Mod. GE 65 - GE 105 Cod. 02AC511 €44,90</p>
<p>KIT RUOTE PNEUMATICHE Ø 250 mm PNEUMATIC WHEELS KIT Ø 250 mm</p>	<p>TERMOSTATO AMBIENTE +5/+30°C CON CAVO L=10 m E SPINA 90° ROOM THERMOSTAT +5/+30°C CABLE 10 m, PLUG 90°</p>	<p>TERMOSTATO AGRICOLTURA/CANTIERE -5/+50°C CON CAVO L=10 m E SPINA 90° HEAVY DUTY THERMOSTAT -5/+50°C CABLE 10 m, PLUG 90°</p>
		
<p>Mod. GE 65 Cod. 02AC598 €116,00</p>	<p>Cod. 02AC581 €49,30</p>	<p>Cod. 02AC582 €98,80</p>
<p>Mod. GE 105 Cod. 02AC599 €116,00</p>		
<p>CARRELLO, MANIGLIA E RUOTE TROLLEY, HANDLE AND WHEELS</p>	<p>FILTRO GASOLIO RISCALDANTE PRE-HEATED FUEL FILTER</p>	<p>KIT COLLEGAMENTO SERBATOIO ESTERNO MONOTUBO CON DE-AERATORE SINGLE-PIPE EXTERNAL FUEL TANK CONNECTION KIT WITH DE-AERATOR</p>
		
<p>Mod. GE 20 Cod. 02AC596 €57,60</p>	<p>Mod. GE 65 - GE 105 Cod. 02AC548 €175,50</p>	<p>Mod. GE 65 - GE 105 Cod. 02AC632 €267,50</p>

## GE - GENERATORI MOBILI D'ARIA CALDA A COMBUSTIONE DIRETTA DIRECT COMBUSTION MOBILE SPACE HEATERS

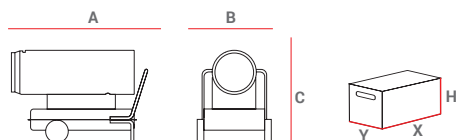

PESI E DIMENSIONI MACCHINA WEIGHTS AND DIMENSIONS MACHINE					IMBALLO PACKAGING			
MOD	A	B	C	Netto/Net	X	Y	H	Lordo/Gross
	[mm]	[mm]	[mm]	[kg]	[mm]	[mm]	[mm]	[kg]
GE 20	720	300	450	20	760	320	425	23
GE 36	1.075	440	615	25	1.050	400	520	29
GE 46	1.075	440	630	38	1.050	400	580	45
GE 65	1.200	555	860	58	1.200	480	900	68
GE 105	1.492	670	1.005	86	1.690	620	1.050	111

		GE 20	GE 36	GE 46	GE 65	GE 105
codice - code		02GE131	02GE102	02GE103	02GE104	02GE105
potenza term. nominale - rated heat power	Hs [kW]	21,4	38,4	49	69,3	111,1
	Hs [kcal/h - BTU/h]	18.369 - 73.110	33.043 - 131.512	42.173 - 167.850	59.565 - 237.067	95.507 - 380.331
rendimento - heat efficiency	[ % ]	100	100	100	100	100
portata d'aria - air flow	[ m <sup>3</sup> /h ]	350	605	1400	2500	4600
temperatura aria - air temperature	a 20°C [ °C ]	92	98	84	77	68
consumo - fuel consumption	[ kg/h ]	1,69	3,04	3,88	5,48	8,85
capacità serbatoio - tank capacity	[ l ]	17	42	42	65	105
potenza elettrica - power consumption 230 V	[ W ]	200	232	400	598	1170
alimentazione elettrica - electrical power	[ V - ph - Hz ]	230 - 1 - 50	230 - 1 - 50	230 - 1 - 50	230 - 1 - 50	230 - 1 - 50
quantità per pallet - pallet quantities	[ pz - pcs ]	20	12	9	1	1
<b>PREZZO - PRICE</b>	<b>EURO</b>	<b>891,00</b>	<b>1.075,00</b>	<b>1.393,00</b>	<b>2.326,00</b>	<b>3.103,00</b>

## Quadro elettrico / Electrical control board

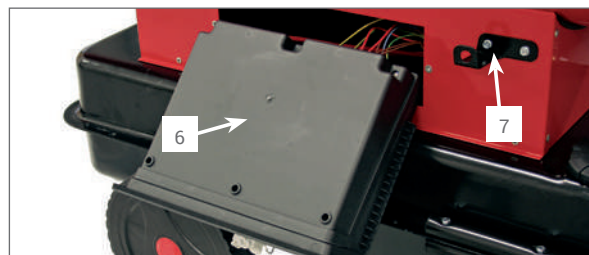
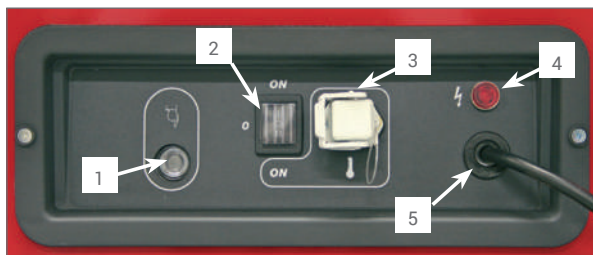

### Legenda

- 1 Pulsante di reset con spia di blocco (rosso), funzionamento (verde) e stand-by (arancione)
- 2 Interruttore di comando a tre posizioni:
  - posizione 0 per macchina ferma,
  - posizione 1 per macchina funzionante in "continuo"
  - posizione 2 per macchina funzionante con termostato ambiente, umidostato, timer
- 3 Presa per termostato ambiente, umidostato, timer
- 4 Spia di presenza tensione
- 5 Uscita cavo di linea
- 6 Coperchio (GE-GE/S 65, GE-GE/S 105, EC-EC/S 55, EC-EC/S 85)
- 7 Supporto cavo elettrico

### Legend

- 1 Reset button with block (red), working (green) and stand-by (orange) indicator light
- 2 Three way control switch:
  - position 0 for stop
  - position 1 for "continuous" on
  - position 2 for on with ambient thermostat, humidistat, timer
- 3 Socket for ambient thermostat, humidistat, timer
- 4 Voltage warning light (connected to the mains)
- 5 Power cord outlet
- 6 Plastic cover (GE-GE/S 65, GE-GE/S 105, EC-EC/S 55, EC-EC/S 85)
- 7 Power cord bracket



# EC







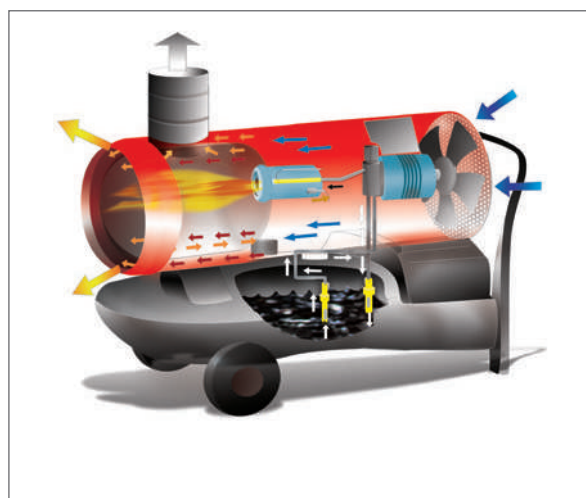



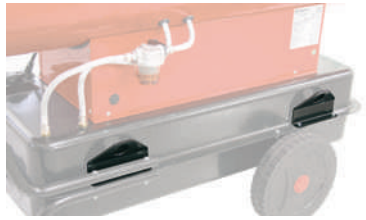

GENERATORI MOBILI D'ARIA CALDA A COMBUSTIONE INDIRECTA  
INDIRECT COMBUSTION MOBILE SPACE HEATERS

## EC - GENERATORI MOBILI D'ARIA CALDA A COMBUSTIONE INDIRECTA

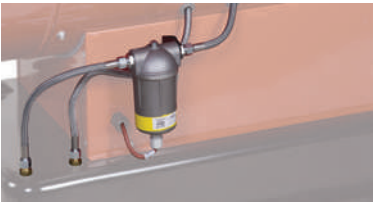
- Bruciatore di gasolio integrato
  - Presa per collegamento a termostato, umidostato o timer
  - Cavo alimentazione elettrica (1,5 m) con spina
  - Camera di combustione in acciaio inox AISI 430; a tre giri di fumo (EC 22, EC 32), a quattro giri di fumo (EC 55, EC 85)
  - Post-ventilazione temporizzata di raffreddamento della camera di combustione
  - Controllo elettronico di fiamma
  - Termostato di surriscaldamento
  - Tubi alimentazione gasolio in gomma resistente agli idrocarburi con rivestimento in maglia rinforzante tessile (EC 22, EC 32), metallica (EC 55, EC 85)
  - Serbatoio in polietilene antiurto (EC 22, EC 32), in acciaio (EC 55, EC 85)
  - Tappo chiusura serbatoio a baionetta
  - Tappo di scarico combustibile dal serbatoio
  - Quadro elettrico di comando (vedere pag. 20)
- *Build-in diesel burner*
  - *Set to be connected to a thermostat or a humidistat or a timer*
  - *Power cord (1,5 m) with plug*
  - *AISI 430 stainless steel combustion chamber; with three smoke revolutions (EC 22, EC 32), with four smoke revolutions (EC 55, EC 85)*
  - *Automatic post ventilation of unit*
  - *Electronic flame-control*
  - *Safety thermostat*
  - *Fuel feed lines in hydrocarbon resistant rubber, with a reinforced textile (EC 22, EC 32) or metal sheath (EC 55, EC 85)*
  - *Tank in tough hydrocarbon resistant polythene (EC 22, EC 32) or steel (EC 55, EC 85)*
  - *Bayonet-type fuel tank cap*
  - *Fuel tank drain plug*
  - *Electric control panel (see page 20)*



ACCESSORI A RICHIESTA / ACCESSORIES ON DEMAND

INDICATORE DI LIVELLO FUEL LEVEL GAUGE	FILTRO RIEMPIMENTO SERBATOIO GASOLIO FUEL TANK FILLER FILTER	STAFFE SOLLEVAMENTO (4 PEZZI) LIFTING BRACKETS (4 PIECES)
		
Cod. 02AC508 €50,90	Cod. 02AC556 €16,80	Mod. EC 55 - EC 85 Cod. 02AC511 €44,90
KIT RUOTE PNEUMATICHE Ø 250 mm PNEUMATIC WHEELS KIT Ø 250 mm	TERMOSTATO AMBIENTE +5/+30°C CON CAVO L=10 m E SPINA 90° ROOM THERMOSTAT +5/+30°C CABLE 10 m, PLUG 90°	TERMOSTATO AGRICOLTURA/CANTIERE -5/+50°C CON CAVO L=10 m E SPINA 90° HEAVY DUTY THERMOSTAT -5/+50°C CABLE 10 m, PLUG 90°
		
Mod. EC 55 Cod. 02AC598 €116,00	Cod. 02AC581 €49,30	Cod. 02AC582 €98,80
Mod. EC 85 Cod. 02AC599 €116,00		
FILTRO GASOLIO RISCALDANTE PRE-HEATED FUEL FILTER	KIT COLLEGAMENTO SERBATOIO ESTERNO MONOTUBO CON DE-AERATORE SINGLE-PIPE EXTERNAL FUEL TANK CONNECTION KIT WITH DE-AERATOR	GUAINA FLESSIBILE IN PVC L= 6 m CON CINGHIA DI FISSAGGIO FLEXIBLE AIR DUCT 6 m LONG WITH CLIP
		
Mod. EC 55 - EC 85 Cod. 02AC548 €175,50	Mod. EC 55 - EC 85 Cod. 02AC632 €267,50	Cod. 02AC562 (Ø 300 mm) €279,70
		Cod. 02AC563 (Ø 350 mm) €320,70
		Cod. 02AC564 (Ø 400 mm) €364,30
RACCORDO UNA VIA COLLEGAMENTO GUAINA ONE-WAY DUCT ADAPTER	RACCORDO DUE VIE COLLEGAMENTO GUAINA TWO-WAY DUCT ADAPTER	KIT COLLEGAMENTO GUAINA RIPRESA ARIA AIR INLET DUCT ADAPTER
		
Mod. EC 32 (Ø 300 mm) Cod. 02AC501 €105,90	Mod. EC 55 (Ø 300 mm) Cod. 02AC546 €250,50	Mod. EC 55 (Ø 430 mm) Cod. 02AC678 €177,10
Mod. EC 55 (Ø 350 mm) Cod. 02AC502 €135,40		Mod. Guaina/Duct 6 m (Ø 450 mm) Cod. 02AC647 €415,30
Mod. EC 85 (Ø 400 mm) Cod. 02AC503 €182,20	Mod. EC 85 (Ø 300 mm) Cod. 02AC505 €308,50	Mod. EC 85 (Ø 500 mm) Cod. 02AC679 €207,50
		Mod. Guaina/Duct 6 m (Ø 510 mm) Cod. 02AC795 €447,90
		Mod. Tutti/All Fascetta fissaggio guaina clip for flexible duct (Ø 400-750 mm) Cod. 02AC663 €11,70

## EC - GENERATORI MOBILI D'ARIA CALDA A COMBUSTIONE INDIRECTA INDIRECT COMBUSTION MOBILE SPACE HEATERS

TUBO SCARICO FUMI INOX L = 1 m STAINLESS STEEL EXHAUST PIPE L = 1 m		TERMINALE PER CAMINO IN INOX STAINLESS STEEL CHIMNEY POT	
			
Mod. Ø 120 mm Cod. 02AC420	€54,60	Mod. Ø 120 mm Cod. 02AC422	€48,10
Mod. Ø 150 mm Cod. 02AC285	€69,10	Mod. Ø 150 mm Cod. 02AC282	€54,60

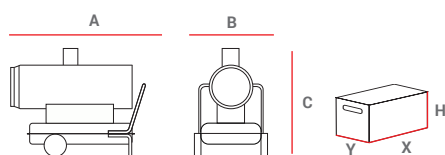

MOD	PESI E DIMENSIONI MACCHINA WEIGHTS AND DIMENSIONS MACHINE				IMBALLO PACKAGING			
	A [mm]	B [mm]	C [mm]	Netto/Net [kg]	X [mm]	Y [mm]	H [mm]	Lordo/Gross [kg]
EC 22	1.075	440	615	40	1.050	400	520	45
EC 32	1.215	440	670	48	1.175	400	605	55
EC 55	1.435	555	940	81	1.310	510	965	95
EC 85	1.740	690	1.025	110	1.690	620	1.050	135

	EC 22	EC 32	EC 55	EC 85
codice - code	02EC101	02EC102	02EC103	02EC104
potenza term. nominale - rated heat power	Hs [kW] 23,4 Hs [kcal/h - BTU/h] 20.108 - 80.032	34,1 28.349 - 116.803	58,6 50.434 - 200.728	90,6 77.934 - 310.177
potenza term. resa - output heat power	Hs [kW] 19,6 Hs [kcal/h - BTU/h] 16.891 - 67.227	28,9 24.828 - 98.815	52,5 45.139 - 179.652	80,2 68.972 - 274.507
rendimento - heat efficiency	[ % ] 84	87,3	89,5	88,5
portata d'aria - air flow	[ m³/h ] 550	1150	2500	4300
salto termico - temperature rise	a 20°C [ °C ] 95	75	66	66
consumo - fuel consumption	[ kg/h ] 1,85	2,7	4,64	7,17
capacità serbatoio - tank capacity	[ l ] 42	42	65	105
potenza elettrica - power consumption 230V	[ W ] 300	370	850	1140
alimentazione elettrica - electrical power	[ V - ph - Hz ] 230 - 1 - 50	230 - 1 - 50	230 - 1 - 50	230 - 1 - 50
Ø camino - Ø flue	[ mm ] 120	150	150	150
Ø guaina uscita aria - Ø outlet hose	1 - 2 vie [ mm ] n.a.	300 - n.a	350 - 300	400 - 300
quantità per pallet - pallet quantities	[ pz - pcs ] 12	6	1	1
<b>PREZZO - PRICE</b>	<b>EURO 1.425,00</b>	<b>1.914,00</b>	<b>2.815,00</b>	<b>3.437,00</b>

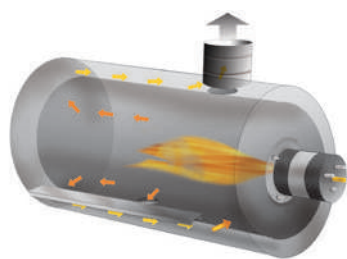

### Camera di combustione a quattro giri di fumo

Le camere di combustione sono realizzate tutte in acciaio inox AISI 430 con scambiatori di calore in acciaio alluminato per un miglior scambio termico con l'aria di raffreddamento. Nei modelli EC 55, EC 85 e PHOEN l'utilizzo dell'innovativa camera di combustione a quattro giri di fumo consente l'aumento dello scambio termico all'interno della stessa con conseguente aumento del raffreddamento dei fumi di combustione tali da consentire un rendimento prossimo al 90%.

### Combustion chamber with four smoke loops

The combustion chambers are manufactured using AISI 430 stainless steel with aluminised steel heat exchangers to guarantee a better heat exchange with the cooling air. In model EC 55, EC 85 and PHOEN the new combustion chamber with four smoke loops allows increasing the heat exchange inside it, and so the combustion smokes cooling, obtaining in this way an output of almost 90%.





# PHOEN

GENERATORI MOBILI D'ARIA CALDA A COMBUSTIONE INDIRECTA  
CON BRUCIATORE DEDICATO A DOPPIO STADIO

*INDIRECT COMBUSTION MOBILE SPACE HEATERS  
WITH DEDICATED TWO STAGES BURNER*

## PHOEN - GENERATORI MOBILI D'ARIA CALDA A COMBUSTIONE INDIRECTA CON BRUCIATORE DEDICATO A DOPPIO STADIO

- Bruciatore gasolio integrato con ventilazione indipendente
- Selettore di potenza: 1° stadio (75 kW), 2° stadio (110 kW)
- Presa per collegamento a termostato, umidistato o timer
- Cavo alimentazione elettrica (1,5 m) con spina
- Camera di combustione in acciaio inox AISI 430 a quattro giri di fumo (vedere pag. 24)
- Termostato ventilazione: accende/spegne il ventilatore solamente quando la camera di combustione è calda/fredda
- Controllo elettronico di fiamma
- Termostato di surriscaldamento, termostato limit
- Tubi alimentazione gasolio in gomma resistente agli idrocarburi con rivestimento in maglia rinforzante metallica
- Tappo chiusura serbatoio a baionetta
- Tappo di scarico combustibile dal serbatoio
- Commutatore inverno ed estate per utilizzo solo come ventilatore
- BM2 dedicated burner, separated from the ventilator
- Power selector: 1° stage (75 kW), 2° stage (110 kW)
- Set to be connected to a thermostat or a humidistat or a timer
- Power cord (1,5 m) with plug
- AISI 430 stainless steel combustion chamber with four smoke revolutions (see page 24)
- Ventilation thermostat: controls the switching on/switching off of the fan only when the combustion chamber is hot/cold
- Electronic flame-control
- Safety thermostat, limit thermostat
- Fuel feed lines in hydrocarbon resistant rubber, with a reinforced metal sheath
- Bayonet-type fuel tank cap
- Fuel tank drain plug
- Dedicated switch to swap from Winter Heating mode to Summer Ventilation mode

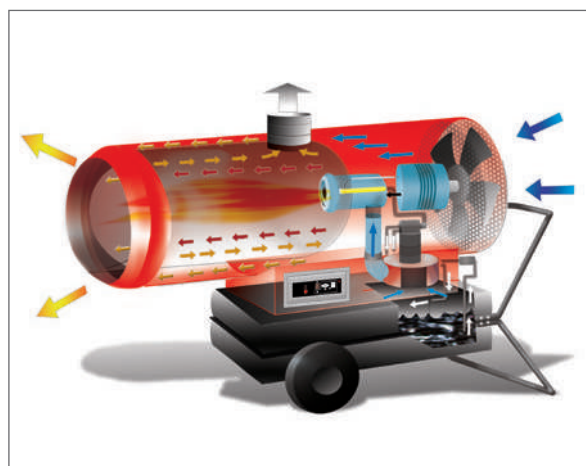

ACCESSORI A RICHIESTA / ACCESSORIES ON DEMAND

<p>INDICATORE DI LIVELLO FUEL LEVEL GAUGE</p>	<p>FILTRO RIEMPIMENTO SERBATOIO GASOLIO FUEL TANK FILLER FILTER</p>	<p>STAFFE SOLLEVAMENTO (4 PEZZI) LIFTING BRACKETS (4 PIECES)</p>
		
<p>Cod. 02AC510 €57,60</p>	<p>Cod. 02AC556 €16,80</p>	<p>Cod. 02AC511 €44,90</p>
<p>KIT SNORKEL PER PRESA ARIA PULITA DALL'ESTERNO MEDIANTE COLLEGAMENTO GUAINA FRESH AIR INTAKE DUCT ADAPTER</p>	<p>TERMOSTATO AMBIENTE +5/+30°C CON CAVO L=10 m E SPINA 90° ROOM THERMOSTAT +5/+30°C CABLE 10 m, PLUG 90°</p>	<p>TERMOSTATO AGRICOLTURA/CANTIERE -5/+50°C CON CAVO L=10 m E SPINA 90° HEAVY DUTY THERMOSTAT -5/+50°C CABLE 10 m, PLUG 90°</p>
		
<p>Mod. Ø 100 mm Cod. 02AC535 €65,80</p>	<p>Cod. 02AC581 €49,30</p>	<p>Cod. 02AC582 €98,80</p>
<p>Mod. Guaina/Duct 5 m (Ø 100 mm) Cod. 02AC577 €140,40</p>		
<p>FILTRO GASOLIO RISCALDANTE PRE-HEATED FUEL FILTER</p>	<p>KIT COLLEGAMENTO SERBATOIO ESTERNO GASOLIO CON DE-AERATORE EXTERNAL FUEL TANK CONNECTION KIT WITH DE-AERATOR</p>	<p>GUAINA FLESSIBILE IN PVC L= 6 m CON CINGHIA DI FISSAGGIO FLEXIBLE AIR DUCT 6 m LONG WITH CLIP</p>
		 <p>T MAX 100° C</p>
<p>Cod. 02AC569 €175,50</p>	<p>Cod. 02AC632 €267,50</p>	<p>Mod. Ø 400 mm Cod. 02AC564 €364,30</p>
		<p>Mod. Ø 500 mm Cod. 02AC566 €446,70</p>
<p>RACCORDO UNA VIA COLLEGAMENTO GUAINA ONE-WAY DUCT ADAPTER</p>	<p>RACCORDO DUE VIE COLLEGAMENTO GUAINA TWO-WAY DUCT ADAPTER</p>	<p>KIT COLLEGAMENTO GUAINA RIPRESA ARIA AIR INLET DUCT ADAPTER WITH SLIDING DOOR</p>
		
<p>Mod. Ø 500 mm Cod. 02AC504 €204,90</p>	<p>Mod. Ø 400 mm Cod. 02AC506 €365,60</p>	<p>Mod. Ø 500 mm Cod. 02AC558 €408,60</p>
		<p>Mod. Guaina/Duct 6 m (Ø 510 mm) Cod. 02AC795 €447,90</p>
		<p>Mod. Tutti/All Fascetta fissaggio guaina clip for flexible duct (Ø 400-750 mm) Cod. 02AC663 €11,70</p>

# PHOEN - GENERATORI MOBILI D'ARIA CALDA A COMBUSTIONE INDIRECTA CON BRUCIATORE DEDICATO A DOPPIO STADIO

## INDIRECT COMBUSTION MOBILE SPACE HEATERS WITH DEDICATED TWO STAGES BURNER

TUBO SCARICO FUMI INOX L=1 m STAINLESS STEEL EXHAUST PIPE L=1 m	TERMINALE PER CAMINO IN INOX STAINLESS STEEL CHIMNEY POT	KIT SERRANDA TAGLIAFUOCO REI 120 FIRE STOP SHUTTER REI 120
		
Mod. Ø 150 mm Cod. 02AC285 €69,10	Mod. Ø 150 mm Cod. 02AC282 €54,60	Mod. Ø 500 mm Cod. 02AC570 €883,70

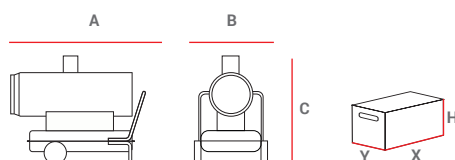

PESI E DIMENSIONI MACCHINA WEIGHTS AND DIMENSIONS MACHINE					IMBALLO PACKAGING			
MOD	A	B	C	Netto/Net	X	Y	H	Lordo/Gross
	[mm]	[mm]	[mm]	[kg]	[mm]	[mm]	[mm]	[kg]
PHOEN 110	1.918	731	1.220	149	1.870	660	1.210	174

		PHOEN 110
codice - code		02EC110
potenza term. nominale 2° stadio - rated heat power 2nd stage	Hs [kW] Hs [kcal/h - BTU/h]	117,26 100.847 - 403.387
potenza term. nominale 1° stadio - rated heat power 1st stage	Hs [kW] Hs [kcal/h - BTU/h]	80 68.804 - 275.214
potenza term. resa 2° stadio - output heat power 2nd stage	Hs [kW] Hs [kcal/h - BTU/h]	105,54 90.762 - 363.048
potenza term. resa 1° stadio - output heat power 1st stage	Hs [kW] Hs [kcal/h - BTU/h]	71,20 61.235 - 244.941
rendimento - heat efficiency	[ % ]	90
portata d'aria - air flow	[ m³/h ]	5.500
salto termico - temperature rise	1°- 2° stadio a 20°C [ °C ]	60 - 75
consumo - fuel consumption	1°-2° stadio [kg/h]	6,33 - 9,278
capacità serbatoio - tank capacity	[ l ]	135
potenza elettrica - power consumption 230 V	[ W ]	1.820
alimentazione elettrica - electrical power	[ V - ph - Hz ]	230 - 1 - 50
Ø camino - Ø flue	[ mm ]	150
Ø guaina uscita aria - Ø outlet hose	1 - 2 vie [ mm ]	500 - 400
quantità per pallet - pallet quantities	[ pz - pcs ]	1
Ø camino - Ø flue	[ mm ]	150
<b>PREZZO - PRICE</b>	<b>EURO</b>	<b>4.392,00</b>

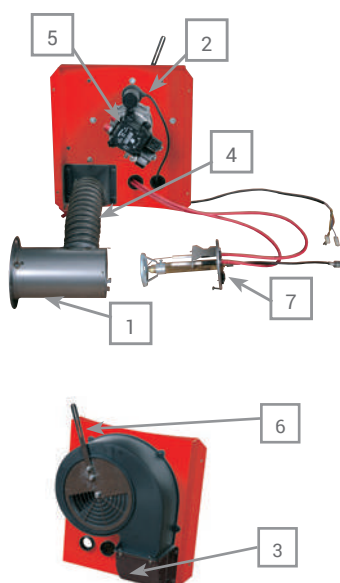

### Bruciatore gasolio BM2

Caratteristica che rende unica questa serie è l'adozione di un bruciatore BM2 dedicato, in sostituzione di quelli tradizionali che si trovano in commercio (Ecoflam, Riello, Lamborghini, ...) o dei sistemi integrati utilizzati sulle macchine economiche dove l'aria di combustione è generata da parte dell'aria del moto-ventilatore.

#### Legenda

- 1 Testa di combustione
- 2 Motore ventilatore bruciatore
- 3 Ventilatore bruciatore
- 4 Tubo flessibile di collegamento moto-ventilatore e testa di combustione
- 5 Pompa gasolio doppio stadio (Suntec)
- 6 Serranda regolazione aria
- 7 Elettrodi - Ugello

### BM2 oil burner

The feature that makes this series unique is that it has a special BM2 burner, that replaces the traditional ones that are on the market (Ecoflam, Riello, Lamborghini, ...) or the integrated systems that are used on cheap machines where the combustion air is generated from the air of the fan-motor.

#### Legend

- 1 Combustion head
- 2 Fan-motor burner
- 3 Burner fan
- 4 Flexible hose connecting fan-motor and combustion head
- 5 Double stage diesel pump (Suntec)
- 6 Air regulation flap
- 7 Electrodes - Nozzle



# JUMBO

GENERATORI D'ARIA CALDA A GRANDE PORTATA A COMBUSTIONE INDIRECTA  
CON VENTILATORE ASSIALE

*INDIRECT COMBUSTION HEAVY DUTY MOBILE SPACE HEATERS WITH AXIAL FAN*

# JUMBO - GENERATORI D'ARIA CALDA A GRANDE PORTATA A COMBUSTIONE INDIRETTA CON VENTILATORE ASSIALE





- Cassetto di copertura del bruciatore che consente la protezione da urti, polvere, acqua, eventi atmosferici e vasca di raccolta del gasolio/condensa
- Bruciatore dotato di presa snorkel per garantire aria di combustione pulita mediante collegamento con guaina di aspirazione dall'esterno
- Il nuovo scambiatore di calore abbinato ai nuovi ventilatori di maggiori prestazioni permettono di ottenere un rendimento termico del 92÷93%
- Un migliore ancoraggio della struttura portante della macchina grazie a robuste staffe di fissaggio che ne consentono la movimentazione su qualunque superficie
- Struttura portante con pannelli rimovibili per il lavaggio interno, anche a macchina appesa
- Pannelli con pieghe di rinforzo a croce per garantire maggior rigidità e robustezza
- Utilizzo esclusivamente di viti e inserti metrici per il fissaggio, no viti autofilettanti
- Protezione di tutti gli elementi soggetti ad urti, eventi atmosferici etc.
- Ventilatore protezione (IP 55):
  - rispondente alle direttive europee ERP 2009/125/CE target 2015;
  - molto silenzioso ( rumore  $\leq 67$  db a 2 metri);
  - 7 pale: alte prestazioni (portata d'aria e pressione statica) per la diffusione omogenea dell'aria calda mediante guaina;
  - boccaglio ventilatore per convogliare l'aria e garantire alta pressione statica;
- Quadro elettrico posteriore di comando (IP 65):
  - posizionato nella parte posteriore evita che sia a contatto con polvere, acqua, neve etc;
  - provvisto di una robusta copertura metallica che consente anche il ricovero di attrezzi e documenti;
- Quadro elettrico anteriore di servizio (IP 65):
  - posizionato nella parte anteriore della macchina dentro il cassetto copertura bruciatore: per evitare che sia a contatto con polvere, acqua, neve per una più facile manutenzione; per un più agevole controllo ed intervento dell'operatore
- Ciascun componente principale (ventilatore, bruciatore, termostati, etc.) è munito di connessioni rapide di collegamento elettrico:
  - velocità di montaggio/smontaggio e di intervento tecnico
  - eliminazione di errori di installazione/smontaggio
- *Burner cover: protects the burner against blows, dust, water, weather and collect diesel fuel/condensation recovery basin*
- *Burner is supplied with snorkel jack to ensure clean air combustion through connection with outdoor air uptake duct*
- *The new heat exchanger with the newly designed higher performance fans ensure heat efficiency of 92 ÷93%*
- *Better anchorage to the machine's weight bearing structure through sturdy attachment rods which allow for movement on any floors*
- *Bearing structure with removable panels for interior washing, also in hanging models*
- *Panels with reinforcement cross pleats to ensure superior rigidity and strength*
- *Exclusive use of metric screws and inserts for fastening, no self-tapping screws*
- *Ventilator (IP 55):*
  - *in conformity with European directives ERP 2009/125/CE target 2015*
  - *very low noise fan (noise level  $\leq 67$ db at 2 meters)*
  - *7-blade fan with high performance (air flow and static pressure) for uniform diffusion of warm air through duct*
  - *fan outlet cone to convey air and ensure high static pressure*
- *Control rear electrical panel (IP 65):*
  - *located at the top rear of the machine to avoid contact with dust, water, snow*
  - *supplied with a sturdy metal cover to prevent damage and unauthorized access; also handy for storage of tools, papers, etc;*
- *Service front electrical panel:*
  - *located at the front of the machine inside the burner cover lid: to prevent contact with dust, water, snow; for easier maintenance; to facilitate controls and maintenance by the operator*
- *Every main component (fan, burner, thermostats, etc.) is supplied with quick couplings of electrical connections IP68:*
  - *fast assembly, disassembly and technical maintenance*
  - *eliminates installation/disassembly mistakes*

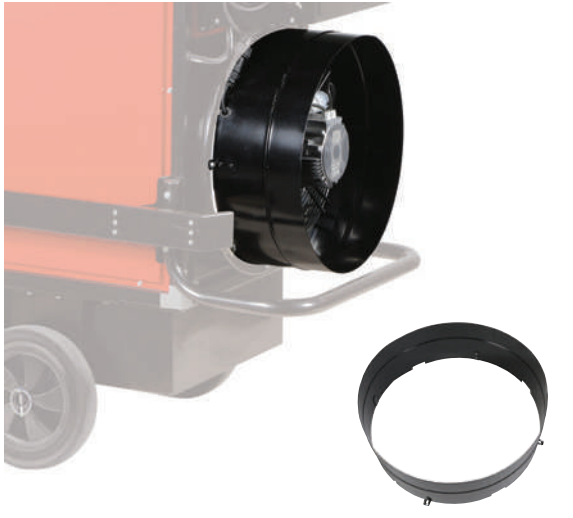

ACCESSORI A RICHIESTA / ACCESSORIES ON DEMAND

RACCORDO 1 VIA ONE WAY ADAPTER		RACCORDO 2 VIE TWO WAYS ADAPTER	
			
			
Mod. JUMBO 85 (Ø 450 mm) Cod. 02AC821	€182,20	Mod. JUMBO 85 (Ø 400 mm) Cod. 02AC822	€203,10
Mod. JUMBO 110 (Ø 500 mm) Cod. 02AC831	€195,80	Mod. JUMBO 110 (Ø 400 mm) Cod. 02AC832	€224,70
Mod. JUMBO 145 (Ø 600 mm) Cod. 02AC841	€211,50	Mod. JUMBO 145 (Ø 500 mm) Cod. 02AC842	€243,90
Mod. JUMBO 185 (Ø 650 mm) Cod. 02AC851	€229,50	Mod. JUMBO 185 (Ø 500 mm) Cod. 02AC852	€271,60
Mod. JUMBO 235 (Ø 700 mm) Cod. 02AC861	€243,90	Mod. JUMBO 235 (Ø 600 mm) Cod. 02AC862	€302,80
RACCORDO 4 VIE FOUR WAYS ADAPTER		GUAINE FLESSIBILI IN PVC L= 6 m CON CINGHIA DI FISSAGGIO FLEXIBLE AIR DUCTS 6 m WITH CLIP	
			
			
Mod. JUMBO 145 (Ø 350 mm) Cod. 02AC843	€260,80	Mod. Ø 350 mm Cod. 02AC563	€320,70
Mod. JUMBO 185 (Ø 350 mm) Cod. 02AC853	€294,40	Mod. Ø 400 mm Cod. 02AC564	€364,30
		Mod. Ø 450/500 mm Cod. 02AC566	€446,70
Mod. JUMBO 235 (Ø 400 mm) Cod. 02AC863	€325,70	Mod. Ø 600 mm Cod. 02AC567	€559,20
		Mod. Ø 650/700 mm Cod. 02AC568	€685,20

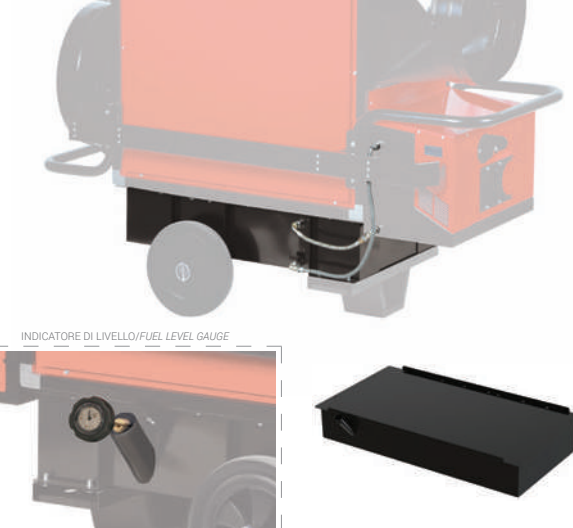
# JUMBO - GENERATORI D'ARIA CALDA A GRANDE PORTATA A COMBUSTIONE INDIRETTA CON VENTILATORE ASSIALE

RACCORDO ASPIRAZIONE 1 VIA AIR INLET ADAPTER	GUAINA RINFORZATA PER RIPRESA ARIA REINFORCED FLEXIBLE AIR INLET DUCT
	
Mod. JUMBO 85 (Ø 505 mm) Cod. 02AC724	Mod. JUMBO 85 (Ø 510 mm, l=6m) Cod. 02AC795
€87,90	€447,90
Mod. JUMBO 110 (Ø 565 mm) Cod. 02AC734	Mod. JUMBO 110 (Ø 570 mm, l=6m) Cod. 02AC796
€95,60	€550,70
Mod. JUMBO 145-185 (Ø 625 mm) Cod. 02AC744	Mod. JUMBO 145-185 (Ø 650 mm, l=6m) Cod. 02AC797
€101,90	€751,80
Mod. JUMBO 235 (Ø 715 mm) Cod. 02AC764	Mod. JUMBO 235 (Ø 720 mm, l=6m) Cod. 02AC798
€114,90	€1.157,20
Mod. Tutti/All Fascetta fissaggio guaina- clip for flexible duct (Ø 400-750 mm) Cod. 02AC663	€11,70
KIT SERBATOIO TANK KIT	KIT PARAURTI LATERALE SIDE BUMPERS KIT
	
Mod. JUMBO 85 (litri/liters= 75) Cod. 02AC827	Mod. JUMBO 85 Cod. 02AC825
€697,00	€170,80
Mod. JUMBO 110 (litri/liters= 90) Cod. 02AC837	Mod. JUMBO 110 Cod. 02AC835
€784,20	€189,80
Mod. JUMBO 145 (litri/liters= 120) Cod. 02AC847	Mod. JUMBO 145 Cod. 02AC845
€834,80	€208,70
Mod. JUMBO 185 (litri/liters= 170) Cod. 02AC857	Mod. JUMBO 185 Cod. 02AC855
€1.035,90	€223,90
Mod. JUMBO 235 (litri/liters= 200) Cod. 02AC867	Mod. JUMBO 235 Cod. 02AC865
€1.081,50	€236,40
Mod. Indicatore di livello - Fuel level gauge Cod. 02AC510	
€57,60	



## JUMBO - INDIRECT COMBUSTION HEAVY DUTY MOBILE SPACE HEATERS WITH AXIAL FAN

KIT STAFFE INFORCOLAMENTO LIFTING KIT	KIT RUOTE PIVOTTANTI SWIVELLING WHEELS KIT	BRUCIATORE GASOLIO ECOFLAM ECOFLAM DIESEL BURNER
		
Mod. JUMBO 85 Cod. 02AC826                    €182,20	Mod. JUMBO 85/110 (Ø 100 mm) Cod. 02AC815*                    €71,60	Mod. JUMBO 85 DIESEL/OIL Cod. 072B111                    €879,00
Mod. JUMBO 110 Cod. 02AC836                    €211,30		Mod. JUMBO 110 DIESEL/OIL Cod. 072B112                    €968,00
Mod. JUMBO 145 Cod. 02AC846                    €225,20	Mod. JUMBO 145/185/235 (Ø 150 mm) Cod. 02AC816*                    €97,50	Mod. JUMBO 145 DIESEL/OIL Cod. 072B113                    €1.221,00
Mod. JUMBO 185 Cod. 02AC856                    €240,40		Mod. JUMBO 185 DIESEL/OIL Cod. 072B114                    €1.221,00
Mod. JUMBO 235 Cod. 02AC866                    €251,70		Mod. JUMBO 235 DIESEL/OIL Cod. 072B115                    €1.274,00
BRUCIATORE GASOLIO RIELLO RIELLO DIESEL BURNER	BRUCIATORE RIELLO GPL + RAMPA GAS LPG RIELLO BURNER + GAS TRAIN	BRUCIATORE RIELLO METANO + RAMPA GAS NATURAL GAS RIELLO BURNER + GAS TRAIN
		
Mod. JUMBO 85 DIESEL/OIL Cod. 076B101                    €879,00	Mod. JUMBO 85 GPL/LPG Cod. 074B101-04                    €2.008,00	Mod. JUMBO 85 METANO/NATURAL GAS Cod. 074B102-04                    €2.008,00
Mod. JUMBO 110 DIESEL/OIL Cod. 076B102                    €968,00	Mod. JUMBO 110 GPL/LPG Cod. 074B103-04                    €2.276,00	Mod. JUMBO 110 METANO/NATURAL GAS Cod. 074B104-04                    €2.276,00
Mod. JUMBO 145 DIESEL/OIL Cod. 076B103                    €1.221,00	Mod. JUMBO 145 GPL/LPG Cod. 074B103-05                    €2.276,00	Mod. JUMBO 145 METANO/NATURAL GAS Cod. 074B104-05                    €2.276,00
Mod. JUMBO 185 DIESEL/OIL Cod. 076B104                    €1.221,00	Mod. JUMBO 185 GPL/LPG Cod. 074B103-07                    €2.276,00	Mod. JUMBO 185 METANO/NATURAL GAS Cod. 074B104-07                    €2.276,00
Mod. JUMBO 235 DIESEL/OIL Cod. 076B105                    €1.274,00	Mod. JUMBO 235 GPL/LPG Cod. 074B105-08                    €2.893,00	Mod. JUMBO 235 METANO/NATURAL GAS Cod. 074B106-08                    €2.893,00
PASSAPARETE SNORKEL + GUAINA FLESSIBILE SNORKEL PASS PLATE + FLEXIBLE DUCT	KIT SERRANDA TAGLIAFUOCO MANDATA ARIA (REI 120) AIR OUTLET FIRE SHUTTER KIT (REI 120)	KIT SERRANDA TAGLIAFUOCO INGRESSO ARIA (REI 120) AIR INLET FIRE SHUTTER KIT (REI 120)
		
Mod. JUMBO 85/110/145/185 (Ø 100 mm) Cod. 02AC793                    €87,90	Mod. JUMBO 85 Cod. 02AC828                    €767,50	Mod. JUMBO 85 (Ø 505 mm) Cod. 02AC908**                    €889,80
Mod. Guaina/Duct (Ø 100 mm - l=5 m) Cod. 02AC577                    €140,40	Mod. JUMBO 110 Cod. 02AC838                    €806,30	Mod. JUMBO 110 (Ø 565 mm) Cod. 02AC909**                    €900,70
Mod. JUMBO 235 (Ø 150 mm) Cod. 02AC794                    €95,60	Mod. JUMBO 145 Cod. 02AC848                    €851,00	Mod. JUMBO 145-185 (Ø 625 mm) Cod. 02AC910**                    €1.041,10
Mod. Guaina/Duct (Ø 150 mm - l=5 m) Cod. 02AC792                    €163,40	Mod. JUMBO 185 Cod. 02AC858                    €890,90	Mod. JUMBO 235 (Ø 715 mm) Cod. 02AC911**                    €1.056,70
Mod. JUMBO 235 Cod. 02AC868                    €929,70	Mod. JUMBO 235 Cod. 02AC868                    €929,70	



\* Montabili solo in assenza di serbatoio installato - Only without tank

\*\* Necessario abbinamento a "raccordo aspirazione" - Additionally it's necessary to buy "air inlet adapter"

# JUMBO - GENERATORI D'ARIA CALDA A GRANDE PORTATA A COMBUSTIONE INDIRETTA CON VENTILATORE ASSIALE

<p>TERMOSTATO AMBIENTE +5/+30°C CON CAVO L=10 m E SPINA 90° ROOM THERMOSTAT +5/+30°C CABLE 10 m, PLUG 90°</p>	<p>TERMOSTATO AGRICOLTURA/CANTIERE -5/+50°C CON CAVO L=10 m E SPINA 90° HEAVY DUTY THERM. -5/+50°C CABLE 10 m, PLUG 90°</p>	<p>TERMOSTATO ELETTRONICO DI PRECISIONE IP55 CON DISPLAY -10/+70°C SENZA CAVO E SPINA ELECTRONIC THERMOSTAT IP55 WITH DISPLAY -10/+70°C WITHOUT POWER CORD AND PLUG</p>
		
Cod. 02AC581                      €49,30	Cod. 02AC582                      €98,80	Cod. 02AC294                      €186,40
<p>FILTRO GASOLIO RISCALDANTE PRE-HEATED FUEL FILTER</p>	<p>KIT COLLEGAMENTO MONOTUBO CON FILTRO DE AERATORE SINGLE PIPE EXTERNAL FUEL TANK CONNECTION KIT WITH DE AERATOR</p>	<p>FILTRO SEPARATORE ACQUA ANTI-WATER FILTER</p>
		
Cod. 02AC818                      €188,80	Cod. 02AC819                      €253,00	Cod. 02AC801                      €106,30
<p>KIT COLLEGAMENTO BITUBO SERBATOIO ESTERNO GASOLIO (l= 5 m) + KIT ATTACCHI RAPIDI TWO-PIPE EXTERNAL FUEL TANK CONNECTION KIT (l=5 m) + QUICK CONNECTIONS KIT</p>	<p>FILTRO GAS GAS FILTER (P.in MAX 2 bar)</p>	<p>FILTRO REGOLATORE GAS GAS FILTER REGULATOR (P.in MAX 2 bar)</p>
		
<p>Mod. Kit collegamento bitubo serbatoio esterno/ Two-pipe external tank connection kit Cod. 02AC668                      €249,30</p>	<p>Mod. JUMBO 85/110/145 (DN 25 - 1") Cod. 03AC603                      €53,40</p>	<p>Mod. JUMBO 85/110/145 GAS METANO - NATURAL GAS (DN 25 3/4" or 1") (Pout set. 20mbar) Cod. 03AC617                      €158,60</p>
<p>Mod. Kit attacchi rapidi (M+F x 2)/ Quick connections kit (M+F x 2) Cod. 02AC669                      €68,00</p>	<p>Mod. JUMBO 185/235 (DN 32 - 1 1/4") Cod. 03AC604                      €103,70</p>	<p>Mod. JUMBO 85/110/145 GPL - LPG (DN 25 3/4" or 1") (Pout set. 30mbar) Cod. 03AC618                      €158,60</p>
		<p>Mod. JUMBO 185/235 (DN 32 - 1 1/4") (Pout non settato - to be set) Cod. 03AC602                      €364,30</p>
<p>TUBO GAS MEDIA PRESSIONE (l= 3 m) + VALVO- LA CHIUSURA + RACCORDI COLLEGAMENTO MEDIUM PRESSURE GAS HOSE (l= 3 m) + GAS VALVE + CONNECTIONS (P. MAX 10 bar)</p>	<p>TUBO GAS BASSA PRESSIONE (l= 2 m) + VALVOLA CHIUSURA + RACCORDI COLLEGAMENTO LOW PRESSURE GAS HOSE (l= 2 m) + GAS VALVE + CONNECTIONS (P.in MAX 0,5 bar)</p>	<p>TUBO SCARICO FUMI INOX L = 1 m STAINLESS STEEL EXHAUST PIPE L = 1 m</p>
		
<p>Mod. JUMBO 85/110/145 Tubo/Hose gas 1" Cod. 03AC615                      €423,70</p>	<p>Mod. JUMBO 85/110/145 Tubo/Hose gas 1" Cod. 03AC612                      €256,70</p>	<p>Mod. JUMBO 85/110 (Ø 150 mm) Cod. 02AC285                      €69,10</p>
<p>Mod. JUMBO 185/235 Tubo/Hose gas 1 1/4" Cod. 03AC616                      €583,50</p>		<p>Mod. JUMBO 145/185/235 (Ø 200 mm) Cod. 02AC287                      €83,60</p>

## JUMBO - INDIRECT COMBUSTION HEAVY DUTY MOBILE SPACE HEATERS WITH AXIAL FAN

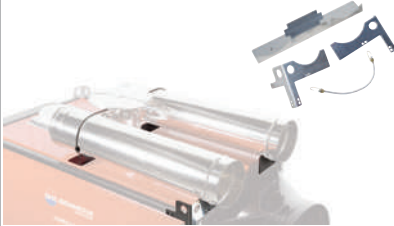
TERMINALE PER CAMINO IN INOX STAINLESS STEEL CHIMNEY POT	KIT SUPPORTO SCARICO FUMI CHIMNEY SUPPORT KIT	KIT RICOVERO SCARICO FUMI CHIMNEY HOLDER KIT
		
<b>Mod. JUMBO 85/110 (Ø 150 mm)</b> <b>Cod. 02AC657</b> <b>€54,60</b>	<b>Mod. JUMBO 85/110</b> <b>Cod. 02AC813</b> <b>€104,70</b>	<b>Mod. JUMBO 85</b> <b>Cod. 02AC824</b> <b>€151,80</b>
		<b>Mod. JUMBO 110</b> <b>Cod. 02AC834</b> <b>€163,20</b>
		<b>Mod. JUMBO 145</b> <b>Cod. 02AC844</b> <b>€174,60</b>
<b>Mod. JUMBO 145/185/235 (Ø 200 mm)</b> <b>Cod. 02AC658</b> <b>€59,80</b>	<b>Mod. JUMBO 145/185/235</b> <b>Cod. 02AC814</b> <b>€125,20</b>	<b>Mod. JUMBO 185</b> <b>Cod. 02AC854</b> <b>€184,70</b>
		<b>Mod. JUMBO 235</b> <b>Cod. 02AC864</b> <b>€196,10</b>

### Quadro elettrico posteriore- Rear electrical panel

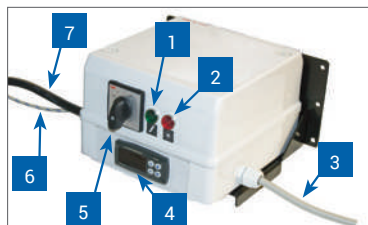

#### Legenda

- 1 Alimentazione elettrica
- 2 Surriscaldamento motore (solo per trifase)
- 3 Cavo motore
- 4 Termoregolatore che consente:
  - il settaggio del termostato FAN per il controllo ventilatore: pre riscaldamento e post ventilazione camera di combustione
  - il settaggio termostati LIMIT per il controllo del bruciatore
  - la visualizzazione delle ore di funzionamento macchina
  - la temperatura uscita aria dalla mandata
  - modifiche settaggio tramite password
- 5 Interruttore 4 posizioni:
  - O**= STOP
  - V**= VENTILAZIONE (ARIA FRESCA)
  - H**= RISCALDAMENTO
  - H+V**= RISCALDAMENTO CON VENTILAZIONE CONTINUA
- 6 Sonda termoregolatore
- 7 Cavo alimentazione

#### Legend

- 1 Electrical power supply
- 2 Motor overheat (only for three-phase)
- 3 Motor cable
- 4 Thermoregulator allows for:
  - FAN thermostat setting to control the fan: before heating and after ventilation of combustion chamber
  - LIMIT thermostat setting for burner control
  - display of machine's hours of work
  - temperature of air exiting the outlet
  - setting changes with password
- 5 Switch 4 positions:
  - O**= STOP
  - V**= VENTILATION (FRESH AIR)
  - H**= HEATING
  - H+V**= HEATING WITH CONTINUOUS VENTILATION
- 6 Heat adjustment probe
- 7 Power cable

### Quadro elettrico anteriore di controllo- Service front electrical panel

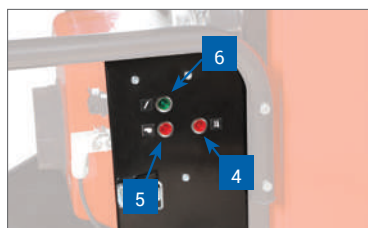
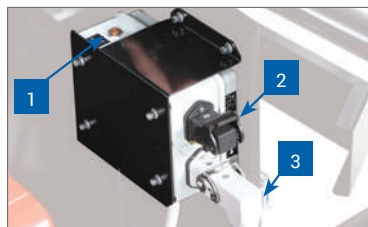

#### Legenda

- 1 OVERHEATING: termostato di sicurezza in caso di surriscaldamento con riarmo manuale
- 2 Presa filtro preriscaldamento
- 3 Presa termostato ambiente/umidostato/timer
- 4 Spia surriscaldamento termostati (overheating limit)
- 5 Spia bruciatore
- 6 Spia alimentazione elettrica

#### Legend

- 1 OVERHEATING: safety thermostat in case of overheating, with manual reset
- 2 Pre-heating filter socket
- 3 Socket for thermostat ambient/humidistat/timer
- 4 Thermostat overheat indicator light (overheating)
- 5 Burner indicator light
- 6 Electric power indicator light

# JUMBO - GENERATORI D'ARIA CALDA A GRANDE PORTATA A COMBUSTIONE INDIRETTA CON VENTILATORE ASSIALE

## INDIRECT COMBUSTION HEAVY DUTY MOBILE SPACE HEATERS WITH AXIAL FAN

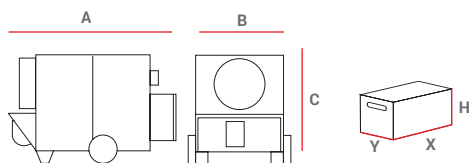

PESI E DIMENSIONI MACCHINA * WEIGHTS AND DIMENSIONS MACHINE					IMBALLO PACKAGING			
MOD	A	B	C	Netto/Net	X	Y	H	Lordo/Gross
	[mm]	[mm]	[mm]	[kg]	[mm]	[mm]	[mm]	[kg]
JUMBO 85	1.648	770	1.133	172	1.600	680	1.135	192
JUMBO 110	1.765	800	1.214	200	1.775	710	1.240	220
JUMBO 145	1.905	890	1.354	254	1.870	780	1.330	274
JUMBO 185	2.013	912	1.414	270	1.980	800	1.390	290
JUMBO 235	2.245	982	1.584	351	2.220	880	1.560	371

\* Macchina completa con bruciatore e uscita 1 via  
Complete machine with burner and one way adapter

MODELLO MODEL		MONOFASE / SINGLE PHASE					TRIFASE / THREE PHASE	
		JUMBO 85M * (OIL-GAS)	JUMBO 110M * (OIL-GAS)	JUMBO 145M * (OIL-GAS)	JUMBO 185M * (OIL-GAS)	JUMBO 235M * (OIL-GAS)	JUMBO 185T * (OIL-GAS)	JUMBO 235T * (OIL-GAS)
CODICE CODE		02AG121	02AG131	02AG141	02AG151	02AG161	02AG152	02AG162
POTENZA TERM. NOMINALE RATED HEAT POWER	Hs [kW] Hs [kcal/h - BTU/h]	85,62 73.630 294.518	110,46 94.999 379.996	144,72 124.455 497.821	185,54 159.563 638.254	235,72 202.715 810.861	185,54 159.563 638.254	235,72 202.715 810.861
POTENZA TERMICA RESA OUTPUT HEAT POWER	Hs [kW] Hs [kcal/h - BTU/h]	79,37 68.255 273.019	102,51 88.159 352.636	134,87 115.992 463.969	171,07 147.117 588.470	216,86 186.498 745.992	171,07 147.117 588.470	216,86 186.498 745.992
RENDIMENTO EFFICIENCY	[ % ]	92,70	92,80	93,20	92,20	92,00	92,20	92,00
PORTATA D'ARIA AIR FLOW	[ m³/h ]	7.200	9.000	12.000	13.000	17.000	13.000	17.000
PRESS. STATICA DISP. AVAILABLE STATIC PRESS	[ Pa - mm H <sub>2</sub> O ]	200 - 20	200 - 20	200 - 20	200 - 20	200 - 20	200 - 20	200 - 20
SALTO TERMICO TEMPERATURE RISE	a 20°C [ °C ]	47	49	48	57	55	57	55
CAMPO DI LAVORO EFFETTIVO EFFECTIVE HEAT RANGE	[ m ]	45	47	46	54	60	54	60
CONSUMO GASOLIO OIL CONSUMPTION	[ kg/h ]	6,77	8,74	11,45	14,68	18,65	14,68	18,65
CONSUMO METANO NATURAL GAS CONSUMPTION G20	[ m³/h ]	7,935	10,433	13,664	17,383	22,095	17,383	22,095
PRESSIONE ALIM. INLET PRESSURE G20	[ mbar ]	20	20	20	20	20	20	20
CONSUMO GPL LPG CONSUMPTION G31	[ m³/h - kg/h ]	3,127 - 6,10	4,191 - 8,07	5,436 - 10,53	6,976 - 13,59	8,819 - 17,17	6,976 - 13,59	8,819 - 17,17
PRESSIONE ALIM. INLET PRESSURE G31	[ mbar ]	37	37	37	37	37	37	37
ALIMENTAZIONE ELETTRICA ELECTRICAL POWER	[ V - ph - Hz ]	230 - 1 - 50	230 - 1 - 50	230 - 1 - 50	230 - 1 - 50	230 - 1 - 50	400-3-50 (230-3-50)◆	400-3-50 (230-3-50)◆
POTENZA ELETTRICA POWER CONSUMPTION	[ W ]	700	1.100	1570	1550	2550	1550	2550
Ø CAMINO Ø FLUE	[ mm ]	150	150	200	200	200	200	200
Ø GUAINA USCITA ARIA / L. MAX. Ø OUTLET HOSE / L. MAX	[ mm/m ] 1 VIA - 1 WAY	500 - 25	500 - 25	600 - 25	700 - 25	700 - 30	700 - 25	700 - 30
	[ mm/m ] 2 VIE - 2 WAYS	400 - 15	400 - 15	500 - 15	500 - 15	600 - 15	500 - 15	600 - 15
	[ mm/m ] 4 VIE - 4 WAYS	-	-	350 - 15	350 - 15	400 - 15	350 - 15	400 - 15
Ø GUAINA SNORKEL / L. MAX. Ø OUTLET SNORKEL / L. MAX	[ mm/m ]	100 - 5	100 - 5	100 - 5	100 - 5	100 - 5	100 - 5	100 - 5
Ø GUAINA RIPRESA ARIA / L. MAX. Ø INLET HOSE / L. MAX	[ mm/m ]	510 - 6	570 - 6	650 - 6	650 - 6	720 - 6	650 - 6	720 - 6
PREZZO - PRICE	EURO	4.008,00	4.737,00	5.456,00	6.320,00	7.400,00	6.199,00	7.342,00

\* Macchina senza bruciatore ed uscita aria - Machine without burner and air adapter

◆Disponibile su richiesta - Available on demand



# TITAN

GENERATORI D'ARIA CALDA A GRANDE PORTATA A COMBUSTIONE INDIRECTA  
CON VENTILATORE CENTRIFUGO

*INDIRECT COMBUSTION HEAVY DUTY MOBILE SPACE HEATERS WITH CENTRIFUGAL FAN*

## TITAN - GENERATORI D'ARIA CALDA A GRANDE PORTATA A COMBUSTIONE INDIRECTA CON VENTILATORE CENTRIFUGO

- Cassetto di copertura del bruciatore che consente la protezione da urti, polvere, acqua, eventi atmosferici e vasca di raccolta del gasolio/condensa
- Bruciatore dotato di presa snorkel per garantire aria di combustione pulita mediante collegamento con guaina di aspirazione dall'esterno
- Il nuovo scambiatore di calore abbinato ai nuovi ventilatori di maggiori prestazioni permettono di ottenere un rendimento termico del 96%;
- Un migliore ancoraggio della struttura portante della macchina grazie a robuste staffe di fissaggio che ne consentono la movimentazione su qualunque superficie
- Struttura portante con pannelli rimovibili per il lavaggio interno, anche a macchina appesa
- Pannelli con pieghi di rinforzo a croce per garantire maggior rigidità e robustezza
- Utilizzo esclusivamente di viti e inserti metrici per il fissaggio, no viti autofilettanti
- Protezione scarico fumi camera di combustione in materiale plastico con catene di ritenzione
- Ventilatore protezione (IP 55):
  - molto silenzioso ( rumore  $\leq 69$  db a 2 metri);
  - ad alta prevalenza e prestazioni che garantisce un'elevata portata d'aria e pressione statica (500 Pa) per la diffusione omogenea ed a lunga distanza dell'aria calda mediante canalizzazioni o guaine;
  - ventilatore ancorato alla struttura portante mediante robusti longheroni e staffe di fissaggio;
  - serranda regolabile di ripristino aria fresca;
- Quadro elettrico posteriore di comando (IP 65):
  - posizionato nella parte posteriore evita che sia a contatto con polvere, acqua, neve etc;
  - provvisto di una robusta copertura metallica che consente anche il ricovero di attrezzi e documenti;
- Quadro elettrico anteriore di servizio (IP 65):
  - posizionato nella parte anteriore della macchina dentro il cassetto copertura bruciatore: per evitare che sia a contatto con polvere, acqua, neve per una più facile manutenzione; per un più agevole controllo ed intervento dell'operatore
- Ciascun componente principale (ventilatore, bruciatore, termostati, etc.) è munito di connessioni rapide di collegamento elettrico:
  - velocità di montaggio/smontaggio e di intervento tecnico;
  - eliminazione di errori di installazione/smontaggio.

- *Burner cover: protects the burner against blows, dust, water, weather and collect diesel fuel/condensation recovery basin*
- *Burner is supplied with snorkel jack to ensure clean air combustion through connection with outdoor air uptake duct*
- *The new heat exchanger with the newly designed higher performance fans ensure heat efficiency of 96%*
- *Better anchorage to the machine's weight bearing structure through sturdy attachment rods which allow for movement on any floors*
- *Bearing structure with removable panels for interior washing, also in hanging models*
- *Panels with reinforcement cross pleats to ensure superior rigidity and strength*
- *Exclusive use of metric screws and inserts for fastening, no self-tapping screws*
- *Protection cap of combustion chamber exhaust in plastic material with retention chains guards*
- *Ventilator (IP 55):*
  - *very low noise fan (noise level  $\leq 69$ db at 2 meters)*
  - *high output, high performance fan guarantees increased air flow and static pressure (500 Pa) for uniform and long distance diffusion of warm air through channels or ducts*
  - *fan anchorage on machine's bearing structure through sturdy rods*
  - *adjustable fresh air re-uptake shutter*
- *Control rear electrical panel (IP 65):*
  - *located at the top rear of the machine to avoid contact with dust, water, snow*
  - *supplied with a sturdy metal cover to prevent damage and unauthorized access; also handy for storage of tools, papers, etc;*
- *Service front electrical panel (IP 65):*
  - *located at the front of the machine inside the burner cover lid: to prevent contact with dust, water, snow; for easier maintenance; to facilitate controls and maintenance by the operator*
- *Every main component (fan, burner, thermostats, etc.) is supplied with quick couplings of electrical connections:*
  - *fast assembly, disassembly and technical maintenance*
  - *eliminates installation/disassembly mistakes*

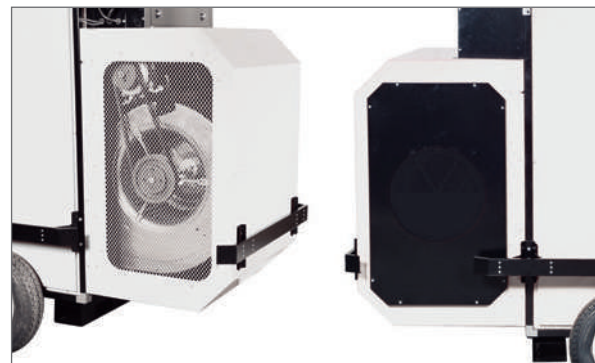
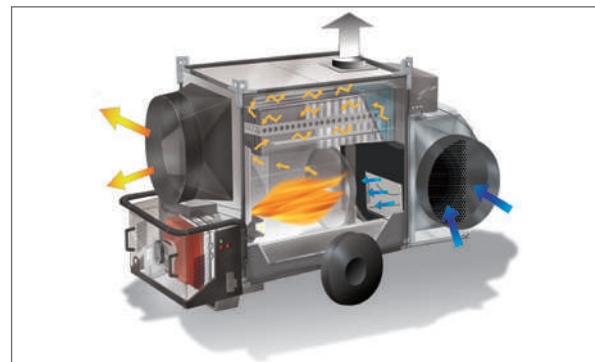

ACCESSORI A RICHIESTA / ACCESSORIES ON DEMAND

RACCORDO 1 VIA ONE WAY ADAPTER		RACCORDO 2 VIE TWO WAYS ADAPTER	
			
			
Mod. TITAN 145 (Ø 600 mm) Cod. 02AC871	€216,30	Mod. TITAN 145 (Ø 500 mm) Cod. 02AC872	€249,90
Mod. TITAN 185 (Ø 650 mm) Cod. 02AC881	€241,50	Mod. TITAN 185 (Ø 500 mm) Cod. 02AC882	€286,00
Mod. TITAN 235 (Ø 700 mm) Cod. 02AC891	€268,00	Mod. TITAN 235 (Ø 600 mm) Cod. 02AC892	€314,90
RACCORDO 4 VIE FOUR WAYS ADAPTER		GUAINE FLESSIBILI IN PVC L= 6 m CON CINGHIA DI FISSAGGIO FLEXIBLE AIR DUCTS 6 m WITH CLIP	
			
			
Mod. TITAN 145 (Ø 350 mm) Cod. 02AC873	€268,00	Mod. Ø 350 mm Cod. 02AC563	€320,70
Mod. TITAN 185 (Ø 350 mm) Cod. 02AC883	€311,20	Mod. Ø 400 mm Cod. 02AC564	€364,30
Mod. TITAN 235 (Ø 400 mm) Cod. 02AC893	€340,10	Mod. Ø 450/500 mm Cod. 02AC566	€446,70
		Mod. Ø 600 mm Cod. 02AC567	€559,20
		Mod. Ø 650/700 mm Cod. 02AC568	€685,20

# TITAN - GENERATORI D'ARIA CALDA A GRANDE PORTATA A COMBUSTIONE INDIRECTA CON VENTILATORE CENTRIFUGO

RACCORDO ASPIRAZIONE 1 VIA AIR INLET ADAPTER	GUAINA RINFORZATA PER RIPRESA ARIA REINFORCED FLEXIBLE AIR INLET DUCT
	
<b>Mod. TITAN 145 (Ø 645 mm)</b> <b>Cod. 02AC874</b>	<b>Mod. TITAN 145 (Ø 650 mm, l=6m)</b> <b>Cod. 02AC797</b>
<b>Mod. TITAN 185 (Ø 715 mm)</b> <b>Cod. 02AC884</b>	<b>Mod. TITAN 185 (Ø 720 mm, l=6m)</b> <b>Cod. 02AC798</b>
<b>Mod. TITAN 235 (Ø 745 mm)</b> <b>Cod. 02AC894</b>	<b>Mod. TITAN 235 (Ø 750 mm, l=6m)</b> <b>Cod. 02AC804</b>
<b>Mod. Tutti/All</b> <b>Fascetta fissaggio guaina- clip for flexible duct (Ø 400-750 mm)</b> <b>Cod. 02AC663</b>	<b>Mod. Tutti/All</b> <b>Fascetta fissaggio guaina- clip for flexible duct (Ø 400-750 mm)</b> <b>Cod. 02AC663</b>
<b>KIT SERBATOIO TANK KIT</b>	<b>KIT PARAURTI LATERALE SIDE BUMPERS KIT</b>
 <p>INDICATORE DI LIVELLO/FUEL LEVEL GAUGE</p>	
<b>Mod. TITAN 145 (litri/liters= 120)</b> <b>Cod. 02AC847</b>	<b>Mod. TITAN 145</b> <b>Cod. 02AC875</b>
<b>Mod. TITAN 185 (litri/liters= 170)</b> <b>Cod. 02AC857</b>	<b>Mod. TITAN 185</b> <b>Cod. 02AC885</b>
<b>Mod. TITAN 235 (litri/liters= 200)</b> <b>Cod. 02AC867</b>	<b>Mod. TITAN 235</b> <b>Cod. 02AC895</b>
<b>Mod. Indicatore di livello - Fuel level gauge</b> <b>Cod. 02AC510</b>	<b>Mod. TITAN 235</b> <b>Cod. 02AC895</b>















## TITAN - INDIRECT COMBUSTION HEAVY DUTY MOBILE SPACE HEATERS WITH CENTRIFUGAL FAN

KIT STAFFE INFORCOLAMENTO LIFTING KIT	KIT RUOTE PIVOTTANTI SWIVELLING WHEELS KIT	BRUCIATORE GASOLIO ECOFLAM ECOFLAM DIESEL BURNER	
			
Mod. TITAN 145 Cod. 02AC846                      €225,20	Mod. TITAN 145 / 185 (Ø 150 mm) Cod. 02AC816*                      €97,50	Mod. TITAN 145 DIESEL/OIL Cod. 072B113                      €1.221,00	
Mod. TITAN 185 Cod. 02AC856                      €240,40		Mod. TITAN 185 DIESEL/OIL Cod. 072B114                      €1.221,00	
Mod. TITAN 235 Cod. 02AC866                      €251,70		Mod. TITAN 235 DIESEL/OIL Cod. 072B115                      €1.274,00	
BRUCIATORE GASOLIO RIELLO RIELLO DIESEL BURNER	BRUCIATORE RIELLO GPL + RAMPA GAS LPG RIELLO BURNER + GAS TRAIN	BRUCIATORE RIELLO METANO + RAMPA GAS NATURAL GAS RIELLO BURNER + GAS TRAIN	
			
Mod. TITAN 145 DIESEL/OIL Cod. 076B103                      €1.221,00	Mod. TITAN 145 GPL/LPG Cod. 074B103-05                      €2.276,00	Mod. TITAN 145 METANO/NATURAL GAS Cod. 074B104-05                      €2.276,00	
Mod. TITAN 185 DIESEL/OIL Cod. 076B104                      €1.221,00	Mod. TITAN 185 GPL/LPG Cod. 074B103-07                      €2.276,00	Mod. TITAN 185 METANO/NATURAL GAS Cod. 074B104-07                      €2.276,00	
Mod. TITAN 235 DIESEL/OIL Cod. 076B105                      €1.274,00	Mod. TITAN 235 GPL/LPG Cod. 074B105-08                      €2.893,00	Mod. TITAN 235 METANO/NATURAL GAS Cod. 074B106-08                      €2.893,00	
PASSAPARETE SNORKEL + GUAINA FLESSIBILE SNORKEL PASS PLATE + FLEXIBLE DUCT	KIT SERRANDA TAGLIAFUOCO MANDATA ARIA (REI 120) AIR OUTLET FIRE SHUTTER KIT (REI 120)	KIT SERRANDA TAGLIAFUOCO INGRESSO ARIA (REI 120) AIR INLET FIRE SHUTTER KIT (REI 120)	
			
Mod. TITAN 145/185 (Ø 100 mm) Cod. 02AC793                      €87,90	Mod. TITAN 145 Cod. 02AC878                      €851,00	Mod. TITAN 145 (Ø 645 mm) Cod. 02AC910**                      €1.041,10	
Mod. Guaina /Duct TITAN 145/185 RIELLO (Ø 100 mm, l=5m) Cod. 02AC577                      €140,40		Mod. TITAN 185 Cod. 02AC888                      €890,90	Mod. TITAN 185 (Ø 715 mm) Cod. 02AC911**                      €1.056,70
Mod. TITAN 235 (Ø 150 mm) Cod. 02AC794                      €95,60		Mod. TITAN 235 Cod. 02AC898                      €929,70	Mod. TITAN 235 (Ø 745 mm) Cod. 02AC913**                      €1.248,10
Mod. Guaina /Duct TITAN 235 RIELLO (Ø 150 mm, l=5m) Cod. 02AC792                      €163,40			



\* Montabili solo in assenza di serbatoio installato - Only without tank

\*\* Necessario abbinamento a "raccordo aspirazione" - Additionally it's necessary to buy "air inlet adapter"

# TITAN - GENERATORI D'ARIA CALDA A GRANDE PORTATA A COMBUSTIONE INDIRECTA CON VENTILATORE CENTRIFUGO

<p>TERMOSTATO AMBIENTE +5/+30°C CON CAVO L=10 m E SPINA 90° ROOM THERMOSTAT +5/+30°C CABLE 10 m, PLUG 90°</p>	<p>TERMOSTATO AGRICOLTURA/CANTIERE -5/+50°C CON CAVO L=10 m E SPINA 90° HEAVY DUTY THERM. -5/+50°C CABLE 10 m, PLUG 90°</p>	<p>TERMOSTATO ELETTRONICO DI PRECISIONE IP55 CON DISPLAY -10/+70°C SENZA CAVO E SPINA ELECTRONIC THERMOSTAT IP55 WITH DISPLAY -10/+70°C WITHOUT POWER CORD AND PLUG</p>
		
Cod. 02AC581                      €49,30	Cod. 02AC582                      €98,80	Cod. 02AC294                      €186,40
<p>FILTRO GASOLIO RISCALDANTE PRE-HEATED FUEL FILTER</p>	<p>KIT COLLEGAMENTO MONOTUBO CON FILTRO DE AERATORE SINGLE PIPE EXTERNAL FUEL TANK CONNECTION KIT WITH DE AERATOR</p>	<p>FILTRO SEPARATORE ACQUA ANTI-WATER FILTER</p>
		
Cod. 02AC818                      €188,80	Cod. 02AC819                      €253,00	Cod. 02AC801                      €106,30
<p>KIT COLLEGAMENTO BITUBO SERBATOIO ESTERNO GASOLIO (l= 5 m) + KIT ATTACCHI RAPIDI TWO-PIPE EXTERNAL FUEL TANK CONNECTION KIT (l=5 m) + QUICK CONNECTIONS KIT</p>	<p>FILTRO GAS GAS FILTER (P.in MAX 2 bar)</p>	<p>FILTRO REGOLATORE GAS GAS FILTER REGULATOR (P.in MAX 2 bar)</p>
		
Mod. Kit collegamento bitubo serbatoio esterno/ Two-pipe external tank connection kit Cod. 02AC668                      €249,30	Mod. TITAN 145 (DN 25 - 1") Cod. 03AC603                      €53,40	Mod. TITAN 145 GAS METANO - NATURAL GAS (DN 25 3/4" or 1") (P.out set. 20mbar) Cod. 03AC617                      €158,60
Mod. Kit attacchi rapidi (M+F x 2)/ Quick connections kit (M+F x 2) Cod. 02AC669                      €68,00	Mod. JUMBO 185/235 (DN 32 - 1 1/4") Cod. 03AC604                      €103,70	Mod. TITAN 145 GPL - LPG (DN 25 3/4" or 1") (P.out set. 30mbar) Cod. 03AC618                      €158,60
		Mod. TITAN 185/235 (DN 32 - 1 1/4") (P.out non settato - to be set) Cod. 03AC602                      €364,30
<p>TUBO GAS MEDIA PRESSIONE (l= 3 m) + VALVO- LA CHIUSURA + RACCORDI COLLEGAMENTO MEDIUM PRESSURE GAS HOSE (l= 3 m) + GAS VALVE + CONNECTIONS (P. MAX 10 bar)</p>	<p>TUBO GAS BASSA PRESSIONE (l= 2 m) + VALVOLA CHIUSURA + RACCORDI COLLEGAMENTO LOW PRESSURE GAS HOSE (l= 2 m) + GAS VALVE + CONNECTIONS (P.in MAX 0,5 bar)</p>	<p>TUBO SCARICO FUMI INOX L = 1 m STAINLESS STEEL EXHAUST PIPE L = 1 m</p>
		
Mod. TITAN 145 Tubo/Hose gas 1" Cod. 03AC615                      €423,70	Mod. TITAN 145 Tubo/Hose gas 1" Cod. 03AC612                      €256,70	Mod. TITAN 145/185/235 (Ø 200 mm) Cod. 02AC287                      €83,60
Mod. TITAN 185/235 Tubo/Hose gas 1 1/4" Cod. 03AC616                      €583,50		

## TITAN - INDIRECT COMBUSTION HEAVY DUTY MOBILE SPACE HEATERS WITH CENTRIFUGAL FAN

TERMINALE PER CAMINO IN INOX STAINLESS STEEL CHIMNEY POT	KIT SUPPORTO SCARICO FUMI CHIMNEY SUPPORT KIT	KIT RICOVERO SCARICO FUMI CHIMNEY HOLDER KIT						
								
<b>Mod. TITAN 145/185/235 (Ø 200 mm)</b> <b>Cod. 02AC658</b> <p style="text-align: right;"><b>€59,80</b></p>	<b>Mod. TITAN 145/185/235</b> <b>Cod. 02AC814</b> <p style="text-align: right;"><b>€125,20</b></p>	<table border="1" style="width: 100%; border-collapse: collapse;"> <tr> <td style="font-size: small;"><b>Mod. TITAN 145</b> <b>Cod. 02AC844</b></td> <td style="text-align: right;"><b>€174,60</b></td> </tr> <tr> <td style="font-size: small;"><b>Mod. TITAN 185</b> <b>Cod. 02AC854</b></td> <td style="text-align: right;"><b>€184,70</b></td> </tr> <tr> <td style="font-size: small;"><b>Mod. TITAN 235</b> <b>Cod. 02AC864</b></td> <td style="text-align: right;"><b>€196,10</b></td> </tr> </table>	<b>Mod. TITAN 145</b> <b>Cod. 02AC844</b>	<b>€174,60</b>	<b>Mod. TITAN 185</b> <b>Cod. 02AC854</b>	<b>€184,70</b>	<b>Mod. TITAN 235</b> <b>Cod. 02AC864</b>	<b>€196,10</b>
<b>Mod. TITAN 145</b> <b>Cod. 02AC844</b>	<b>€174,60</b>							
<b>Mod. TITAN 185</b> <b>Cod. 02AC854</b>	<b>€184,70</b>							
<b>Mod. TITAN 235</b> <b>Cod. 02AC864</b>	<b>€196,10</b>							

### Quadro elettrico posteriore- Rear electrical panel

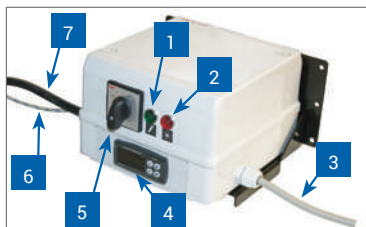

#### Legenda

- 1 Alimentazione elettrica
- 2 Surriscaldamento motore (solo per trifase)
- 3 Cavo motore
- 4 Termoregolatore che consente:
  - il settaggio del termostato FAN per il controllo ventilatore: pre riscaldamento e post ventilazione camera di combustione
  - il settaggio termostati LIMIT per il controllo del bruciatore
  - la visualizzazione delle ore di funzionamento macchina
  - la temperatura uscita aria dalla mandata
  - modifiche settaggio tramite password
- 5 Interruttore 4 posizioni:
  - O**= STOP
  - V**= VENTILAZIONE (ARIA FRESCA)
  - H**= RISCALDAMENTO
  - H+V**= RISCALDAMENTO CON VENTILAZIONE CONTINUA
- 6 Sonda termoregolatore
- 7 Cavo alimentazione

#### Legend

- 1 Electrical power supply
- 2 Motor overheat (only for three-phase)
- 3 Motor cable
- 4 Thermoregulator allows for:
  - FAN thermostat setting to control the fan: before heating and after ventilation of combustion chamber
  - LIMIT thermostat setting for burner control
  - display of machine's hours of work
  - temperature of air exiting the outlet
  - setting changes with password
- 5 Switch 4 positions:
  - O**= STOP
  - V**= VENTILATION (FRESH AIR)
  - H**= HEATING
  - H+V**= HEATING WITH CONTINUOUS VENTILATION
- 6 Heat adjustment probe
- 7 Power cable

### Quadro elettrico anteriore di controllo- Service front electrical panel

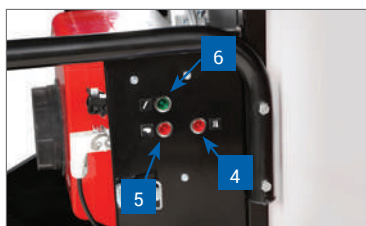
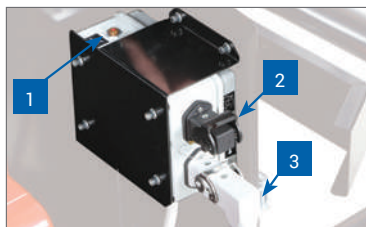

#### Legenda

- 1 OVERHEATING: termostato di sicurezza in caso di surriscaldamento con riarmo manuale
- 2 Presa filtro preriscaldamento
- 3 Presa termostato ambiente/umidostato/timer
- 4 Spia surriscaldamento termostati (overheating limit)
- 5 Spia bruciatore
- 6 Spia alimentazione elettrica

#### Legend

- 1 OVERHEATING: safety thermostat in case of overheating, with manual reset
- 2 Pre-heating filter socket
- 3 Socket for thermostat ambient/humidistat/timer
- 4 Thermostat overheat indicator light (overheating)
- 5 Burner indicator light
- 6 Electric power indicator light

# TITAN - GENERATORI D'ARIA CALDA A GRANDE PORTATA A COMBUSTIONE INDIRETTA CON VENTILATORE CENTRIFUGO

## INDIRECT COMBUSTION HEAVY DUTY MOBILE SPACE HEATERS WITH CENTRIFUGAL FAN

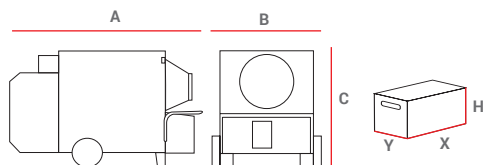

PESI E DIMENSIONI MACCHINA* WEIGHTS AND DIMENSIONS MACHINE*					IMBALLO PACKAGING			
MOD	A	B	C	Netto/Net	X	Y	H	Lordo/Gross
	[mm]	[mm]	[mm]	[kg]	[mm]	[mm]	[mm]	[kg]
TITAN 145	2191	900	1515	361	-	-	-	-
1/2	-	-	-	-	1910	780	1490	375
2/2	-	-	-	-	730	400	500	15
TITAN 185	2413	920	1620	430	-	-	-	-
1/2	-	-	-	-	2140	800	1595	435
2/2	-	-	-	-	760	400	500	15
TITAN 235	2630	1042	1840	535	-	-	-	-
1/2	-	-	-	-	2328	861	1764	524
2/2	-	-	-	-	820	450	560	22

\* Macchina completa con bruciatore e uscita 1 via  
Complete machine with burner and one way adapter

MODELLO MODEL	CODICE CODE	MONOFASE / SINGLE PHASE	TRIFASE / THREE PHASE	
		TITAN 145M * (OIL-GAS)	TITAN 185T * (OIL-GAS)	TITAN 235T * (OIL-GAS)
		02AG171	02AG182 (V 400,3~50 Hz)	02AG192 (V 400,3~50 Hz)
POTENZA TERM. NOMINALE RATED HEAT POWER	Hs [kW] Hs [kcal/h - BTU/h]	144,72 124.455 497.821	185,54 159.563 638.254	235,72 202.715 810.861
POTENZA TERMICA RESA OUTPUT HEAT POWER	Hs [kW] Hs [kcal/h - BTU/h]	138,93 119.477 477.908	178,12 153.181 612.724	227,47 195.620 782.480
RENDIMENTO EFFICIENCY	[%]	96,00	96,00	96,50
PORTATA D'ARIA AIR FLOW	[m³/h]	14.000	16.000	20.000
PRESS. STATICA DISP. AVAILABLE STATIC PRESS	[Pa - mm H <sub>2</sub> O]	300 - 30	500 - 50	500 - 50
SALTO TERMICO TEMPERATURE RISE	a 20°C [°C]	42	46	47
CAMPO DI LAVORO EFFETTIVO EFFECTIVE HEAT RANGE	[m]	56	63	70
CONSUMO GASOLIO OIL CONSUMPTION	[kg/h]	11,45	14,68	18,65
CONSUMO METANO NATURAL GAS CONSUMPTION G20	[m³/h]	13,855	17,682	22,035
PRESSIONE ALIM. INLET PRESSURE G20	[mbar]	20	20	20
CONSUMO GPL LPG CONSUMPTION G31	[m³/h - kg/h]	5,403 - 10,57	6,981 - 13,63	8,637 - 16,92
PRESSIONE ALIM. INLET PRESSURE G31	[mbar]	37	37	37
ALIMENTAZIONE ELETTRICA ELECTRICAL POWER	[V - ph - Hz]	230 - 1 - 50	400-3-50 (230-3-50)♦	400-3-50 (230-3-50)♦
POTENZA ELETTRICA POWER CONSUMPTION	[W]	3100	4200	4850 (230V) 4970 (400V)
Ø CAMINO Ø FLUE	[mm]	200	200	200
Ø GUAINA USCITA ARIA / L. MAX. Ø OUTLET HOSE / L. MAX	[mm/m] 1 VIA - 1 WAY	600 - 50	700 - 50	700 - 50
	[mm/m] 2 VIE - 2 WAYS	500 - 30	500 - 30	600 - 30
	[mm/m] 4 VIE - 4 WAYS	350 - 25	350 - 25	400 - 25
Ø GUAINA SNORKEL / L. MAX. Ø OUTLET SNORKEL / L. MAX	[mm/m]	100 - 6	100 - 6	150 - 6
Ø GUAINA RIPRESA ARIA / L. MAX. Ø INLET HOSE / L. MAX	[mm/m]	650 - 10	720 - 10	750 - 10
PREZZO - PRICE	EURO	6.963,00	8.182,00	9.322,00

\* Macchina senza bruciatore ed uscita aria - Machine without burner and air adapter

♦ Disponibile su richiesta - Available on demand



# SCUDO

GENERATORI D'ARIA CALDA A BASAMENTO A COMBUSTIONE INDIRECTA  
CON VENTILATORE CENTRIFUGO

*BASE FRAMED INDIRECT COMBUSTION SPACE HEATERS WITH CENTRIFUGAL FAN*

## SCUDO - GENERATORI D'ARIA CALDA A BASAMENTO A COMBUSTIONE INDIRECTA CON VENTILATORE CENTRIFUGO

- Basamento per movimentazione mediante inforcolamento
- Carter di protezione anteriore con porta dotata di serratura per copertura bruciatore
- Carter posteriore a protezione del ventilatore centrifugo con raccordo laterale di aspirazione/ripresa aria
- Basamento di protezione parte superiore con ganci per sollevamento/fissaggio
- Gancio di sollevamento centrale
- Pannelli rimovibili per il lavaggio interno con pieghi di rinforzo a croce per garantire maggior rigidità e robustezza
- Utilizzo esclusivamente di viti e inserti metrici per il fissaggio, no viti autofilettanti
- Il nuovo scambiatore di calore abbinato ai nuovi ventilatori di maggiori prestazioni permettono di ottenere un rendimento termico del 96%;
- Ventilatore protezione (IP 55):
  - molto silenzioso (rumore  $\leq 69$  db a 2 metri);
  - ad alta prevalenza e prestazioni che garantisce un'elevata portata d'aria e pressione statica (500 Pa) per la diffusione omogenea ed a lunga distanza dell'aria calda mediante canalizzazioni o guaine;
  - ventilatore ancorato alla struttura portante mediante robusti longheroni e staffe di fissaggio;
  - serranda regolabile di ripristino aria fresca;
- Quadro elettrico posteriore di comando (IP 65):
  - posizionato nella parte posteriore evita che sia a contatto con polvere, acqua, neve etc;
  - provvisto di una robusta copertura metallica che consente anche il ricovero di attrezzi e documenti;
- Quadro elettrico anteriore di servizio (IP 65):
  - posizionato nella parte anteriore della macchina dentro il cassetto copertura bruciatore: per evitare che sia a contatto con polvere, acqua, neve per una più facile manutenzione; per un più agevole controllo ed intervento dell'operatore
- Base adapted for moving with a fork lift
- Front protective casing with lockable door for burner cover
- Rear protective casing for the centrifugal fan with air intake/aspiration side joint
- Protective base for the upper part with lifting/fastening hooks
- Central lifting hook
- Removable panels for internal washing with reinforcement cross folds to ensure more rigidity and strength
- Exclusive use of metric screws and inserts for fastening, no self-tapping screws
- The new heat exchanger combined with the new higher performance fans, achieve a thermal output of 96%
- Fan protection IP55:
  - very silent (noise level  $\leq 69$  db at 2 meters);
  - high output and performances which ensure high air delivery and static pressure (500 Pa) for uniform diffusion and through long distances of warm air through canals or ducts;
  - fan anchored to weight-bearing structure through sturdy beams and fastening brackets;
  - adjustable shutter for fresh air restoration;
- Rear electric control panel (IP65):
  - situated at the rear of the machine to avoid contact with dust, water, snow, etc...
  - supplied with a sturdy metal cover which can also be used to stow tools and documents;
- Front service control panel (IP 65):
  - situated at the front of the machine, inside the burner cover casing: to avoid contact with dust, water, snow; for easier maintenance; for more convenient control and intervention operations



ACCESSORI A RICHIESTA / ACCESSORIES ON DEMAND

RACCORDO 1 VIA ONE WAY ADAPTER	RACCORDO 2 VIE TWO WAYS ADAPTER
	
<p>Mod. Ø 700 mm Cod. 02AC891</p> <p style="text-align: right;">€268,00</p>	<p>Mod. Ø 600 mm Cod. 02AC892</p> <p style="text-align: right;">€314,90</p>
RACCORDO 4 VIE FOUR WAYS ADAPTER	ADATTATORE USCITA ARIA 90° 90° OUTLET ADAPTER
	
<p>Mod. Ø 400 mm Cod. 02AC893</p> <p style="text-align: right;">€340,10</p>	<p>Cod. 02AC930</p> <p style="text-align: right;">€405,50</p>
GUAINE FLESSIBILI IN PVC L= 6 m CON CINGHIA DI FISSAGGIO FLEXIBLE AIR DUCTS 6 m WITH CLIP	RACCORDO ASPIRAZIONE 1 VIA AIR INLET ADAPTER
	
<p>Mod. Ø 650/700 mm Cod. 02AC568</p> <p style="text-align: right;">€685,20</p>	<p>Mod. Ø 745 mm Cod. 02AC894</p> <p style="text-align: right;">€299,80</p>









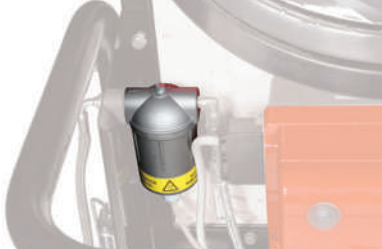

## SCUDO - GENERATORI D'ARIA CALDA A BASAMENTO A COMBUSTIONE INDIRECTA CON VENTILATORE CENTRIFUGO

<b>KIT SERRANDA TAGLIAFUOCO MANDATA ARIA(REI 120) AIR OUTLET FIRE SHUTTER KIT(REI 120)</b>		<b>KIT SERRANDA TAGLIAFUOCO INGRESSO ARIA (REI 120) AIR INLET FIRE SHUTTER KIT (REI 120)</b>	
			
Cod. 02AC898	€929,70	Mod. Ø 745 mm Cod. 02AC913*	€1.248,10
<b>GUAINA RINFORZATA PER RIPRESA ARIA REINFORCED FLEXIBLE AIR INLET DUCT</b>		<b>PASSAPARETE SNORKEL + GUAINA FLESSIBILE SNORKEL PASS PLATE + FLEXIBLE DUCT</b>	
			
Mod. Ø 750 mm, l=6m Cod. 02AC804	€1.273,50	Mod. Ø 150 mm Cod. 02AC794	€95,60
Mod. SCUDO 235 Fascetta fissaggio guaina-clip for flexible duct (Ø 400-750 mm) Cod. 02AC663	€11,70	Mod. Guaina /Duct RIELLO (Ø 150 mm, l=5m) Cod. 02AC792	€163,40
<b>BRUCIATORE GASOLIO ECOFLAM RIELO DIESEL BURNER</b>		<b>BRUCIATORE RIELLO GPL + RAMPA GAS LPG RIELLO BURNER + GAS TRAIN</b>	
			
Mod. DIESEL/OIL Cod. 076B105	€1.274,00	Mod. GPL/LPG Cod. 074B105-08	€2.893,00
<b>BRUCIATORE RIELLO METANO + RAMPA GAS NATURAL GAS RIELLO BURNER + GAS TRAIN</b>		<b>TERMOSTATO AMBIENTE +5/+30°C CON CAVO L=10 m E SPINA 90° ROOM THERMOSTAT +5/+30°C CABLE 10 m, PLUG 90°</b>	
			
Mod. METANO/NATURAL GAS Cod. 074B106-08		€2.893,00	
<b>TERMOSTATO AGRICOLTURA/CANTIERE -5/+50°C CON CAVO L=10 m E SPINA 90° HEAVY DUTY THERM. -5/+50°C CABLE 10 m, PLUG 90°</b>		<b>TERMOSTATO ELETTRONICO DI PRECISIONE IP55 CON DISPLAY -10/+70°C SENZA CAVO E SPINA ELECTRONIC THERMOSTAT IP55 WITH DISPLAY -10/+70°C WITHOUT POWER CORD AND PLUG</b>	
			
Cod. 02AC581	€49,30	Cod. 02AC582	€98,80
Cod. 02AC294		€186,40	

\* Necessario abbinamento a "raccordo aspirazione" - Additionally it's necessary to buy "air inlet adapter"



**SCUDO - BASE FRAMED INDIRECT COMBUSTION SPACE HEATERS WITH CENTRIFUGAL FAN**

<b>FILTRO GASOLIO RISCALDANTE PRE-HEATED FUEL FILTER</b>	<b>KIT COLLEGAMENTO MONOTUBO CON FILTRO DE AERATORE SINGLE PIPE EXTERNAL FUEL TANK CONNECTION KIT WITH DE AERATOR</b>	<b>FILTRO SEPARATORE ACQUA ANTI-WATER FILTER</b>
		
<b>Cod. 02AC818</b> <b>€188,80</b>	<b>Cod. 02AC819</b> <b>€253,00</b>	<b>Cod. 02AC801</b> <b>€106,30</b>
<b>FILTRO GAS GAS FILTER (P.in MAX 2 bar)</b>	<b>FILTRO REGOLATORE GAS GAS FILTER REGULATOR (P.in MAX 2 bar)</b>	<b>TUBO GAS MEDIA PRESSIONE (l = 3 m) + VALVOLA CHIUSURA + RACCORDI COLLEGAMENTO MEDIUM PRESSURE GAS HOSE (l = 3 m) + GAS VALVE + CONNECTIONS (P. MAX 10 bar)</b>
		
<b>Mod. DN 32 - 1 1/4"</b> <b>Cod. 03AC604</b> <b>€103,70</b>	<b>Mod. (DN 32 - 1 1/4") (Pout non settato - to be set)</b> <b>Cod. 03AC602</b> <b>€364,30</b>	<b>Mod. Tubo/Hose gas 1 1/4"</b> <b>Cod. 03AC616</b> <b>€583,50</b>
<b>KIT COLLEGAMENTO BITUBO SERBATOIO ESTERNO GASOLIO (l = 5 m) + KIT ATTACCHI RAPIDI TWO-PIPE EXTERNAL FUEL TANK CONNECTION KIT (l=5 m) + QUICK CONNECTIONS KIT</b>	<b>TUBO SCARICO FUMI INOX (L = 1 m) STAINLESS STEEL EXHAUST PIPE (L = 1 m)</b>	<b>TERMINALE PER CAMINO IN INOX STAINLESS STEEL CHIMNEY POT</b>
		
<b>Mod. Kit collegamento bitubo serbatoio esterno/ Two-pipe external tank connection kit</b> <b>Cod. 02AC668</b> <b>€249,30</b>	<b>Mod. Ø 200 mm</b> <b>Cod. 02AC287</b> <b>€83,60</b>	<b>Mod. Ø 200 mm</b> <b>Cod. 02AC658</b> <b>€59,80</b>
<b>Mod. Kit attacchi rapidi (M+F x 2)/ Quick connections kit (M+F x 2)</b> <b>Cod. 02AC669</b> <b>€68,00</b>		
<b>KIT SUPPORTO SCARICO FUMI CHIMNEY SUPPORT KIT</b>		
		
<b>Cod. 02AC814</b> <b>€125,20</b>		

# SCUDO - GENERATORI D'ARIA CALDA A BASAMENTO A COMBUSTIONE INDIRECTA CON VENTILATORE CENTRIFUGO

## BASE FRAMED INDIRECT COMBUSTION SPACE HEATERS WITH CENTRIFUGAL FAN

### Quadro elettrico posteriore- Rear electrical panel

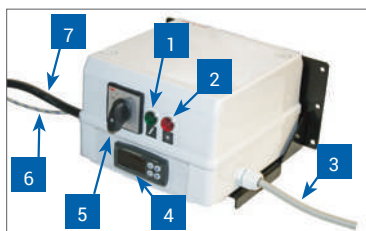
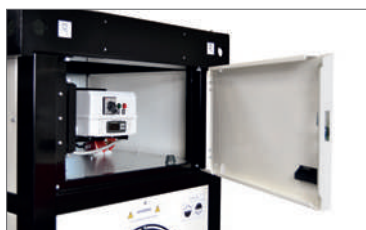

#### Legenda

- 1 Alimentazione elettrica
- 2 Surriscaldamento motore (solo per trifase)
- 3 Cavo motore
- 4 Termoregolatore che consente:
  - il settaggio del termostato FAN per il controllo ventilatore; pre riscaldamento e post ventilazione camera di combustione
  - il settaggio termostati LIMIT per il controllo del bruciatore
  - la visualizzazione delle ore di funzionamento macchina
  - la temperatura uscita aria dalla mandata
  - modifiche settaggio tramite password
- 5 Interruttore 4 posizioni:
  - O**= STOP
  - V**= VENTILAZIONE (ARIA FRESCA)
  - H**= RISCALDAMENTO
  - H+V**= RISCALDAMENTO CON VENTILAZIONE CONTINUA
- 6 Sonda termoregolatore
- 7 Cavo alimentazione

#### Legend

- 1 Electrical power supply
- 2 Motor overheat (only for three-phase)
- 3 Motor cable
- 4 Thermoregulator allows for:
  - FAN thermostat setting to control the fan: before heating and after ventilation of combustion chamber
  - LIMIT thermostat setting for burner control
  - display of machine's hours of work
  - temperature of air exiting the outlet
  - setting changes with password
- 5 Switch 4 positions:
  - O**= STOP
  - V**= VENTILATION (FRESH AIR)
  - H**= HEATING
  - H+V**= HEATING WITH CONTINUOUS VENTILATION
- 6 Heat adjustment probe
- 7 Power cable

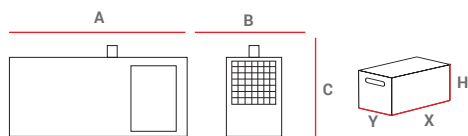

PESI E DIMENSIONI MACCHINA* WEIGHTS AND DIMENSIONS MACHINE*					IMBALLO PACKAGING			
MOD	A	B	C	Netto/Net	X	Y	H	Lordo/Gross
	[mm]	[mm]	[mm]	[kg]	[mm]	[mm]	[mm]	[kg]
SCUDO 235	2790	900	1766	856	2790	900	1766	856

\* Macchina completa con bruciatore e uscita 1 via  
Complete machine with burner and one way adapter

		SCUDO 235T* (OIL-GAS)
codice - code		02AG196 (V 400,3~50 hZ)
potenza term. nominale - rated heat power	Hs [kW] Hs [kcal/h - BTU/h]	235,72 202.715 - 810.861
potenza term. resa - output heat power	Hs [kW] Hs [kcal/h - BTU/h]	227,47 195.620 - 782.480
rendimento - heat efficiency	[ % ]	96,50
portata d'aria - air flow	[ m³/h ]	20.000
pressione statica disp. - available static press	[ Pa- mm H <sub>2</sub> O ]	500 - 50
salto termico - temperature rise	a 20°C [ °C ]	47
campo di lavoro effettivo - effective heat range	[ m ]	70
consumo gasolio - oil consumption	[ kg/h ]	18,65
consumo metano - natural gas consumption G20	[ m³/h ]	22,035
pressione alim. - inlet pressure G20	[ mbar ]	20
consumo GPL - LPG consumption G31	[ m³/h - kg/h ]	8,637 - 16,92
pressione alim. - inlet pressure G31	[ mbar ]	37
alimentazione elettrica - electrical power	[ V - ph - Hz ]	400 - 3 - 50 (230 - 3 - 50)◆
potenza elettrica - power consumption	[ W ]	4850 (230V) - 4970 (400V)
∅ camino - ∅ flue	[ mm ]	200
∅ guaina uscita aria/L. max - ∅ outlet hose/L.max	[ mm/m ] 1 VIA	700 - 50
	[ mm/m ] 2 VIE	600 - 30
	[ mm/m ] 4 VIE	400 - 25
∅ guaina snorkel/L. max - ∅ outlet snorkel/L.max	[ mm/m ]	150 - 6
∅ guaina ripresa aria/L. max - ∅ inlet hose/L.max	[ mm/m ]	750 - 10
<b>PREZZO - PRICE</b>	<b>EURO</b>	<b>12.323,00</b>

\* Macchina senza bruciatore ed uscita aria - Machine without burner and air adapter

◆ Disponibile su richiesta - Available on demand



FT

SERBATOIO TRASPORTABILE IN POLIETILENE PER GASOLIO  
TRANSPORTABLE TANK IN POLYETHYLENE FOR DIESEL

## FT - SERBATOIO TRASPORTABILE IN POLIETILENE PER GASOLIO TRANSPORTABLE TANK IN POLYETHYLENE FOR DIESEL

- Per il trasporto di gasolio in esenzione totale secondo 1.1.3.1c ADR
- Caratteristiche materiale: compattezza, resistenza abbinata alla leggerezza
- Capacità 230 lt - 440 lt
- Indicatore di livello
- Tappo di carico con sfiato
- Coperchio con chiusura a chiave
- Alloggiamento per il posizionamento di cinghie d'ancoraggio ed imbrocchi per il sollevamento a pieno carico con forche
- Polyethylene transportable tank of diesel fuel in total exemption from 1.1.3.1c ADR
- Material features: compact, ultra strong, yet light
- Capacity 230 lts - 440 lts
- Level gauge
- Filler with air vent
- Cover with key operated lock
- Handles for manual lift while empty and spaces for forklift forks when it is full



## ACCESSORI A RICHIESTA / ACCESSORIES ON DEMAND

KIT ALIMENTAZIONE MACCHINA MONOTUBO HEATER OIL SUPPLY SINGLE PIPE KIT (D. 3/8" - TUBO/HOSE l= 5 m)		GRUPPO EROGATORE COMPLETO COMPLETE REGULATOR GROUP	
			
Cod. 99AM033	€102,60	Mod. (D. 3/4" - Tubo/Hose l= 4 m) 12 V - 40 l/min Cod. 99AM030	€450,30
		Mod. (D. 3/4" - Tubo/Hose l= 4 m) 24 V - 40 l/min Cod. 99AM035	€450,30
		Mod. (D. 3/4" - Tubo/Hose l= 4 m) 230 V (50Hz) - 40 l/min Cod. 99AM034	€450,30

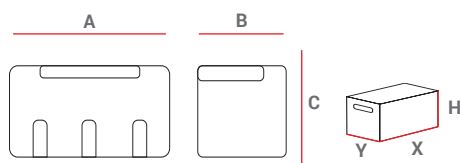

PESI E DIMENSIONI MACCHINA WEIGHTS AND DIMENSIONS MACHINE				
MOD	A	B	C	Netto/Net
	[mm]	[mm]	[mm]	[kg]
FT 230	600	800	600	27
FT 440	1200	700	800	55,5

		FT 230	FT 440
codice - code		99AM031	99AM032
Litri - Liters	[lt]	230	440
PREZZO - PRICE	EURO	1.047,00	1.728,00



# GP

GENERATORI MOBILI D'ARIA CALDA A COMBUSTIONE DIRETTA  
(MANUALI ED AUTOMATICI)



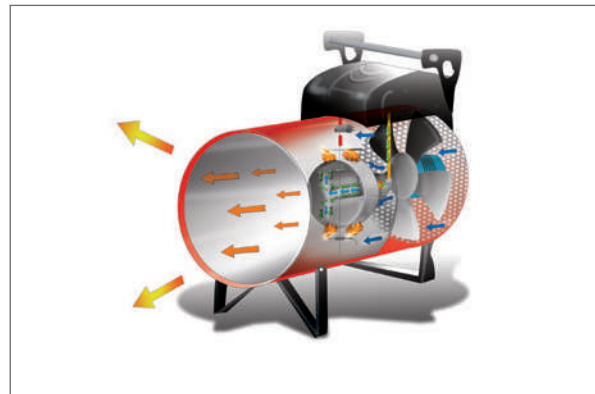

*DIRECT COMBUSTION MOBILE SPACE HEATERS (MANUAL AND AUTOMATIC)*

## GP - GENERATORI MOBILI D'ARIA CALDA A COMBUSTIONE DIRETTA (MANUALI ED AUTOMATICI)







- Bruciatore di GPL incorporato
  - Termostato di sicurezza
  - Controllo con termocoppia e valvola gas (M)
  - Controllo elettronico di fiamma con rilevazione a ionizzazione (A)
  - Cavo alimentazione elettrica con spina l= 1,5 m
  - Accensione manuale con sistema piezo-elettrico (M)
  - Presa per collegamento a termostato, umidostato o timer (A)
  - Controllo di bassa tensione di alimentazione (GP105A)
  - Conforme alle normative UNI EN 1596:2008
- Built-in LPG burner
  - Safety thermostat
  - Thermal flame detector (M)
  - Electronic flame-control by an ionisation electrode (A)
  - Power cord with plug l= 1,5 m
  - Piezoelectric ignition (M)
  - Set to be connected to a thermostat or a humidistat or a timer (A)
  - Low supply voltage control (GP105A)
  - Conforms to norms UNI EN 1596:2008



## ACCESSORI IN DOTAZIONE / SUPPLIED ACCESSORIES

TUBO GAS CON RACCORDI (1,5 m) GAS HOSE WITH CONNECTIONS (1,5 m)	RIDUTTORI DI PRESSIONE PRESSURE REDUCERS			
		1	2	A <b>Mod.</b> GP 10 <b>Tipo/Type</b> Fisso/Fix <b>Cod.</b> T30338-D <b>bar</b> 0,3
		1	3	B <b>Mod.</b> GP 18 <b>Tipo/Type</b> Regolabile/Adjust. <b>bar</b> 0,7±0,3 <b>Cod.</b> T30340-D
		1	4	C <b>Mod.</b> GP 30 - GP 45 - GP 65 - GP 85 - GP 105 <b>Tipo/Type</b> Regolabile/Adjust. <b>bar</b> 1,5±0,4 <b>Cod.</b> T30332-D
<b>Cod.</b> I40554	ADATTATORI ADAPTORS			
	1 - Paese/Country	2 - Paese/Country	3 - Paese/Country	4 - Paese/Country
	AT/BG/CY/DK/DE/EE/ LT/LV/MK/MT/RO/TR/ NL/RU	NL <b>Cod.</b> T30528	IT/GR/AL <b>Cod.</b> T30529	BE/CZ/ES/FR/HR/HU/ LU/PL/PT/SI/SK/MA/RU <b>Cod.</b> T30527

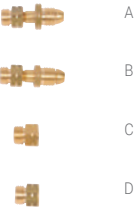
## ACCESSORI A RICHIESTA / ACCESSORIES ON DEMAND

TERMOSTATO AMBIENTE +5/+30°C CON CAVO L=10 m E SPINA 90° ROOM THERM. +5/+30°C CABLE 10 m, PLUG 90°	TERMOSTATO AGRICOLTURA/CANTIERE -5/+50°C CON CAVO L=10 m E SPINA 90° HEAVY DUTY THERM. -5/+50°C CABLE 10 m, PLUG 90°	TUBO GAS CON RACCORDI (3 m) GAS HOSE WITH CONNECTIONS (3 m)
		
<b>Mod.</b> Automatic <b>Cod.</b> 02AC581 <b>€49,30</b>	<b>Mod.</b> Automatic <b>Cod.</b> 02AC582 <b>€98,80</b>	<b>Mod.</b> GP 30 - GP 45 - GP 65 - GP 85 GP 105 <b>Cod.</b> 03AC511 <b>€16,80</b>
VALVOLA DI SICUREZZA STOP GAS STOP GAS VALVE	ADATTATORI PER REGOLATORE LPG ADAPTORS	KIT CARRELLO TROLLEY KIT
		
<b>Mod.</b> GP 10 - GP 18 <b>Cod.</b> 03AC503 <b>€20,70</b>	A - <b>Paese/Country</b> NO/SE/USA/CA/MEX/ AUS/NZ/RA <b>Cod.</b> 03AC508 <b>€13,70</b>	<b>Mod.</b> GP 30 - GP45 - GP65 <b>Cod.</b> 03AC501 <b>€78,70</b>
	B - <b>Paese/Country</b> GB/FI/IS <b>Cod.</b> 03AC507 <b>€13,70</b>	
<b>Mod.</b> GP 30 - GP 45 - GP 65 - GP 85 GP 105 <b>Cod.</b> 03AC504 <b>€23,30</b>	C - <b>Paese/Country</b> BR <b>Cod.</b> 03AC509 <b>€6,90</b>	<b>Mod.</b> GP 85 <b>Cod.</b> 03AC502 <b>€85,10</b>
	D - <b>Paese/Country</b> CH/NL <b>Cod.</b> 03AC510 <b>€6,90</b>	

**GP - GENERATORI MOBILI D'ARIA CALDA A COMBUSTIONE DIRETTA (MANUALI ED AUTOMATICI)**  
**DIRECT COMBUSTION MOBILE SPACE HEATERS (MANUAL AND AUTOMATIC)**

MOD	PESI E DIMENSIONI MACCHINA WEIGHTS AND DIMENSIONS MACHINE				IMBALLO PACKAGING			
	A	B	C	Netto/Net	X	Y	H	Lordo/Gross
	[mm]	[mm]	[mm]	[kg]	[mm]	[mm]	[mm]	[kg]
GP 10 M	367	180	280	5	392	277	217	6
GP 18 M	425	180	280	5,5	447	277	217	6,5
GP 30 M - A	505	277	511	10	542	387	315	11
GP 45 M - A	575	277	511	12	610	387	315	13
GP 65 M - A	580	317	538	14	632	432	350	15
GP 85 M - A	700	317	538	16	732	432	350	17
GP 105 A	835	438	606	26	845	460	470	29

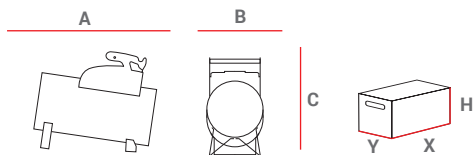

**VERSIONE MANUALE / MANUAL VERSION**

		GP 10M	GP 18M	GP 30M	GP 45M	GP 65M	GP 85M
codice - code		03GP101	03GP102	03GP103	03GP104	03GP105	03GP106
potenza term. nominale max max rated heat power	Hs [kW] Hs [kcal/h - BTU/h]	10,7 9.200 - 36.510	18,58 15.975 - 63.400	31,4 27.000 - 107.140	46,73 40.180 - 159.450	66,25 56.965 - 226.055	84,81 72.925 - 289.385
potenza term. nominale min min rated heat power	Hs [kW] Hs [kcal/h - BTU/h]	10,7 9.200 - 36.510	11,3 9.715 - 38.560	15,08 12.965 - 51.455	22,76 19.570 - 77.660	32,33 27.800 - 110.315	40,95 35.210 - 139.730
consumo gas max max fuel consumption	[kg/h]	0,653	1,213	2,014	2,979	4,268	5,53
consumo gas min min fuel consumption	[kg/h]	0,653	0,744	1,004	1,454	2,097	2,458
pressione gas gas pressure	[bar]	0,3	0,7÷0,3	1,5÷0,4	1,5÷0,4	1,5÷0,4	1,5÷0,4
rendimento heat efficiency	[%]	100	100	100	100	100	100
portata d'aria - air flow	[m³/h]	420	520	1.100	1.250	1.950	2.550
temperatura aria air temperature	a 20°C [°C]	35	35	49	62	87	65
potenza elettrica power consumption 230V	[W]	46	50	90	112	140	240
alimentazione elettrica electrical power	[V - ph - Hz]	230 - 1 - 50	230 - 1 - 50	230 - 1 - 50/60	230 - 1 - 50/60	230 - 1 - 50/60	230 - 1 - 50
quantità per pallet pallet quantities	[pz - pcs]	72	72	36	24	24	18
<b>PREZZO - PRICE</b>	<b>EURO</b>	<b>286,00</b>	<b>315,00</b>	<b>435,00</b>	<b>521,00</b>	<b>708,00</b>	<b>891,00</b>

**VERSIONE AUTOMATICA / AUTOMATIC VERSION**

		GP 30A	GP 45A	GP 65A	GP 85A	GP 105A
codice - code		03GP153	03GP154	03GP155	03GP156	03GP157
potenza term. nominale max max rated heat power	Hs [kW] Hs [kcal/h - BTU/h]	31,4 27.000 - 107.140	46,73 40.180 - 159.450	66,25 56.965 - 226.055	84,81 72.925 - 289.385	108,71 93.590 - 371.390
potenza term. nominale min min rated heat power	Hs [kW] Hs [kcal/h - BTU/h]	15,08 12.965 - 51.455	22,76 19.570 - 77.660	32,33 27.800 - 110.315	40,95 35.210 - 139.730	48,81 41.970 - 166.545
consumo gas max - max fuel consumption	[kg/h]	2,014	2,979	4,268	5,53	6,899
consumo gas min - min fuel consumption	[kg/h]	1,004	1,454	2,097	2,458	3,094
pressione gas - gas pressure	[bar]	1,5÷0,4	1,5÷0,4	1,5÷0,4	1,5÷0,4	1,5÷0,4
rendimento - heat efficiency	[%]	100	100	100	100	100
portata d'aria - air flow	[m³/h]	1.100	1.250	1.950	2.550	3.700
temperatura aria - air temperature	a 20°C [°C]	49	62	87	65	71
potenza elettrica power consumption 230V	[W]	90	112	140	240	400
alimentazione elettrica - electrical power	[V - ph - Hz]	230 - 1 - 50/60	230 - 1 - 50/60	230 - 1 - 50/60	230 - 1 - 50	230 - 1 - 50
quantità per pallet - pallet quantities	[pz - pcs]	36	24	24	18	12
<b>PREZZO - PRICE</b>	<b>EURO</b>	<b>637,00</b>	<b>725,00</b>	<b>913,00</b>	<b>1.095,00</b>	<b>1.389,00</b>





# GW

GENERATORI MOBILI D'ARIA CALDA AD IRRAGGIAMENTO/CONVEZIONE  
*MOBILE SPACE HEATERS BY RADIATION/CONVECTION*

## GW - GENERATORI MOBILI D'ARIA CALDA AD IRRAGGIAMENTO/CONVEZIONE MOBILE LPG SPACE HEATERS BY RADIATION/CONVECTION

- |   |  |
|---|--|
| <ul style="list-style-type: none"> <li>● Autonomi: non necessitano di energia elettrica</li> <li>● Bruciatore di GPL incorporato</li> <li>● Controllo con termocoppia e valvola gas</li> <li>● Dispositivo anti ribaltamento</li> <li>● Accensione manuale con sistema piezo-elettrico</li> </ul> | <ul style="list-style-type: none"> <li>● <i>Stand-alone: no electricity required</i></li> <li>● <i>Built-in LPG burner</i></li> <li>● <i>Thermal flame detector</i></li> <li>● <i>Anti roll-over protection system</i></li> <li>● <i>Piezoelectric ignition</i></li> </ul> |
|---|--|



### ACCESSORI IN DOTAZIONE / SUPPLIED ACCESSORIES

TUBO GAS CON RACCORDI (5 m) GAS HOSE WITH CONNECTIONS (5 m)	RIDUTTORI DI PRESSIONE PRESSURE REDUCERS	VALVOLA DI SICUREZZA STOP GAS STOP GAS VALVE	
	<div style="display: flex; justify-content: space-around; margin-top: 5px;"> <span>1</span> <span>2</span> <span>3</span> <span>4</span> </div>		
ADATTATORI ADAPTORS			
1 - Paese/Country	2 - Paese/Country	3 - Paese/Country	4 - Paese/Country
AT/BG/CY/DK/DE/EE/LT/LV/ MK/MT/RO/TR/NL/RU	NL	IT/GR/AL	BE/CZ/ES/FR/HR/HU/LU/PL/PT/SI/SK/ MA/RU

### ACCESSORI A RICHIESTA / ACCESSORIES ON DEMAND

ADATTATORI PER REGOLATORE LPG ADAPTORS	
<div style="display: flex; justify-content: space-around; margin-top: 5px;"> <span>A</span> <span>C</span> </div>	A - Paese/Country NO/SE/USA/CA/MEX/ AUS/NZ/RA Cod. 03AC508 <span style="float: right;"><b>€13,70</b></span>
<div style="display: flex; justify-content: space-around; margin-top: 5px;"> <span>B</span> <span>D</span> </div>	B - Paese/Country GB/FI/IS Cod. 03AC507 <span style="float: right;"><b>€13,70</b></span>
	C - Paese/Country BR Cod. 03AC509 <span style="float: right;"><b>€6,90</b></span>
	D - Paese/Country CH/NL Cod. 03AC510 <span style="float: right;"><b>€6,90</b></span>

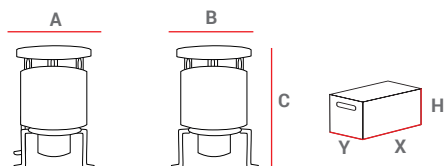

PESI E DIMENSIONI MACCHINA WEIGHTS AND DIMENSIONS MACHINE					IMBALLO PACKAGING			
MOD	A	B	C	Netto/Net	X	Y	H	Lordo/Gross
	[mm]	[mm]	[mm]	[kg]	[mm]	[mm]	[mm]	[kg]
GW 32	528	528	676	17	450	450	700	18

		GW 32
codice - code		03GW101
potenza term. nominale max max rated heat power	Hs [kW] Hs [kcal/h - BTU/h]	31,4 27.000 - 108.000
potenza term. nominale min min rated heat power	Hs [kW] Hs [kcal/h - BTU/h]	15,08 12.965 - 51.864
consumo gas max max fuel consumption	[ kg/h ]	2,13
consumo gas min min fuel consumption	[ kg/h ]	1,025
pressione gas gas pressure	[ bar ]	1,5±0,4
rendimento heat efficiency	[ % ]	100
quantità per pallet pallet quantities	[ pz - pcs ]	12
<b>PREZZO - PRICE</b>	<b>EURO</b>	<b>412,00</b>



EK

GENERATORI MOBILI D'ARIA CALDA A CORRENTE ELETTRICA  
ELECTRICAL MOBILE SPACE HEATERS

## EK - GENERATORI MOBILI D'ARIA CALDA A CORRENTE ELETTRICA

- Resistenze elettriche corazzate AISI 321 avvolte a profilo ad alto scambio termico
- Termostato ambiente incorporato
- Selettore di potenza
- Cavo alimentazione elettrica (1,5 m) con spina (EK 3)
- Termostato di sicurezza a riarmo manuale
- Griglia anteriore in acciaio inox
- Canalizzabile fino a 6 m (no EK3)
- Possibilità di impilamento
- Presa termostato esterno (EK 30)
- Extra strength elements AISI 321 for high performance
- Built-in room thermostat
- Selector switch
- Power cord (1,5 m) with plug (EK 3)
- Safety thermostat with manual reset
- Stainless steel front grid
- Duct able up to 6 m long (no EK3)
- Possibility to stack-ability
- Set to be connected to an external thermostat (EK 30)

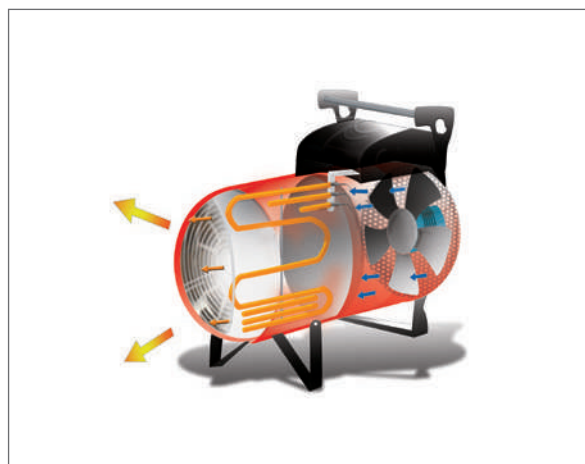

ACCESSORI A RICHIESTA / ACCESSORIES ON DEMAND

<p>TERMOSTATO AMBIENTE +5/+30°C CON CAVO L=10 m E SPINA 90° ROOM THERMOSTAT +5/+30°C CABLE 10 m, PLUG 90°</p>	<p>TERMOSTATO AGRICOLTURA/CANTIERE -5/+50°C CON CAVO L=10 m E SPINA 90° HEAVY DUTY THERM. -5/+50°C CABLE 10 m, PLUG 90°</p>	<p>SPINA 4-5 POLI 4-5 PIN PLUG</p>												
														
<p>Mod. EK 30 Cod. 02AC581</p> <p>€49,30</p>	<p>Mod. EK 30 Cod. 02AC582</p> <p>€98,80</p>	<table border="0"> <tr> <td>Mod. 3P+⊥ EK 10 Cod. 06AC102 16A</td> <td>€10,70</td> </tr> <tr> <td>Mod. 3P+⊥ EK 15 / EK 22 Cod. 06AC103 32A</td> <td>€17,40</td> </tr> <tr> <td>Mod. 3P+⊥+N EK 10 Cod. 06AC104 16A</td> <td>€13,20</td> </tr> <tr> <td>Mod. 3P+⊥+N EK 15 / EK 22 Cod. 06AC105 32A</td> <td>€20,10</td> </tr> <tr> <td>Mod. 3P+⊥+N EK 30 Cod. 06AC108 63A</td> <td>€107,50</td> </tr> <tr> <td>Mod. 3P+⊥ EK 30 Cod. 06AC109 63A</td> <td>€107,50</td> </tr> </table>	Mod. 3P+⊥ EK 10 Cod. 06AC102 16A	€10,70	Mod. 3P+⊥ EK 15 / EK 22 Cod. 06AC103 32A	€17,40	Mod. 3P+⊥+N EK 10 Cod. 06AC104 16A	€13,20	Mod. 3P+⊥+N EK 15 / EK 22 Cod. 06AC105 32A	€20,10	Mod. 3P+⊥+N EK 30 Cod. 06AC108 63A	€107,50	Mod. 3P+⊥ EK 30 Cod. 06AC109 63A	€107,50
Mod. 3P+⊥ EK 10 Cod. 06AC102 16A	€10,70													
Mod. 3P+⊥ EK 15 / EK 22 Cod. 06AC103 32A	€17,40													
Mod. 3P+⊥+N EK 10 Cod. 06AC104 16A	€13,20													
Mod. 3P+⊥+N EK 15 / EK 22 Cod. 06AC105 32A	€20,10													
Mod. 3P+⊥+N EK 30 Cod. 06AC108 63A	€107,50													
Mod. 3P+⊥ EK 30 Cod. 06AC109 63A	€107,50													
<p>ADATTATORE GUAINA DUCT ADAPTER</p>	<p>GUAINA FLESSIBILE IN PVC l= 6 m CON CINGHIA DI FISSAGGIO FLEXIBLE AIR DUCT 6 m LONG WITH CLIP</p>	<p>KIT CARRELLO TROLLEY KIT</p>												
														
<p>Mod. EK 10 - EK 15 (Ø 300 mm) Cod. 06AC101</p> <p>€76,10</p>	<p>Mod. EK 10 - EK 15 (Ø 300 mm) Cod. 02AC562</p> <p>€279,70</p>	<p>Mod. EK 10 - EK 15 Cod. 03AC501</p> <p>€78,70</p>												
<p>Mod. EK 22 (Ø 350 mm) Cod. 06AC106</p> <p>€82,60</p>	<p>Mod. EK 22 (Ø 350 mm) Cod. 02AC563</p> <p>€320,70</p>													
<p>Mod. EK 30 (Ø 500 mm) Cod. 06AC107</p> <p>€89,00</p>	<p>Mod. EK 30 (Ø 500 mm) Cod. 02AC566</p> <p>€446,70</p>	<p>Mod. EK 22 Cod. 03AC502</p> <p>€85,10</p>												

# EK - GENERATORI MOBILI D'ARIA CALDA A CORRENTE ELETTRICA ELECTRICAL MOBILE SPACE HEATERS

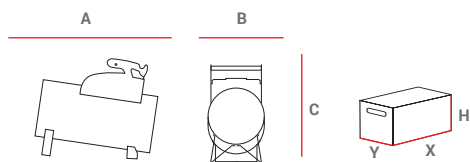

MOD	PESI E DIMENSIONI MACCHINA WEIGHTS AND DIMENSIONS MACHINE			IMBALLO PACKAGING				
	A	B	C	Netto/Net	X	Y	H	Lordo/Gross
	[mm]	[mm]	[mm]	[kg]	[mm]	[mm]	[mm]	[kg]
EK 3 C	367	180	280	5	392	277	217	6
EK 10 C	505	277	511	13	542	387	315	14
EK 15 C	575	277	511	15	610	387	315	16
EK 22 C	700	317	538	21	732	432	350	22
EK 30 C	899	558	706	41	940	600	680	48

		EK 3 C	EK 10 C	EK 15 C	EK 22 C	EK 30 C
codice - code		06EK101	06EK102	06EK103	06EK104	06EK106
potenza term. nominale max max rated heat power	Hs [kW] Hs [kcal/h - BTU/h]	3 2.580 - 10.235	10 8.600 - 34.120	15 12.900 - 51.185	22 18.915 - 75.065	30 25.818 - 102.455
potenza term. nominale min. min rated heat power	Hs [kW] Hs [kcal/h - BTU/h]	1,5 1.290 - 5.185	6,6 5.675 - 22.520	10 8.600 - 34.120	15 12.900 - 51.185	20 17.212 - 68.304
rendimento - heat efficiency	[ % ]	100	100	100	100	100
portata d'aria - air flow	[ m <sup>3</sup> /h ]	450	1.500	2.000	3.050	5.100
salto termico - temperature rise	a 20°C [ °C ]	44,5 - 32	48,3 - 30,5	54,3 - 35	56 - 38	56 - 38
corrente massima - current max	[ A ]	13 - 6,5	13,6 - 7,1	21 - 13,8	30 - 21	43 - 28
alimentazione elettrica - electrical power	[ V - ph - Hz ]	230 - 1 - 50	400 - 3 - 50	400 - 3 - 50	400 - 3 - 50	400 - 3 - 50/60
connessioni - connections	[ n° ]	-	3P+⊥ 3P+⊥+N	3P+⊥ 3P+⊥+N	3P+⊥ 3P+⊥+N	3P+⊥
quantità per pallet - pallet quantities	[ pz - pcs ]	72	36	24	18	6
<b>PREZZO - PRICE</b>	<b>EURO</b>	<b>315,00</b>	<b>491,00</b>	<b>708,00</b>	<b>1.009,00</b>	<b>1.762,00</b>

Possibilità di impilamento (EK 10-15-22-30)  
Possibility to stack-ability (EK 10-15-22-30)





EKT

GENERATORI MOBILI D'ARIA CALDA A CORRENTE ELETTRICA CON VENTILATORE CENTRIFUGO  
*ELECTRICAL MOBILE SPACE HEATERS WITH CENTRIFUGAL FAN*

## EK T - GENERATORI MOBILI D'ARIA CALDA A CORRENTE ELETTRICA CON VENTILATORE CENTRIFUGO

- Studiato per applicazioni in tensostrutture, tende, emergenze ed applicazioni mobili dove non è consentito l'utilizzo di combustibili fossili
  - Resistenze elettriche corazzate AISI 321 avvolte a profilo ad alto scambio termico
  - Presa termostato esterno
  - Selettore di potenza (20 kW, 30 kW, 40 kW)
  - Cavo alimentazione elettrica (0,5 m)
  - Ruote pivotanti e ganci di sollevamento
  - Pre riscaldamento e Post ventilazione
  - Termostati: FAN per il controllo ventilatore; OVERHEATING termostato di sicurezza in caso di surriscaldamento con riarmo manuale
  - Griglia anteriore e posteriore in acciaio inox
  - Possibilità di impilamento
  - Struttura portante con pannelli rimovibili per il lavaggio interno, anche a macchina appesa
  - Utilizzo esclusivamente di viti e inserti metrici per il fissaggio, no viti autofilettanti
  - Ventilatore centrifugo con protezione IP 55:
    - molto silenzioso ( rumore  $\leq 67$  db a 2 metri);
    - ad alta prevalenza e prestazioni che garantisce un' elevata portata d'aria e pressione statica per la diffusione omogenea ed a lunga distanza dell'aria calda mediante canalizzazioni o guaine;
    - ventilatore ancorato alla struttura portante mediante robusti longheroni e staffe di fissaggio;
  - Quadro elettrico di comando (IP 65):
    - collegabile a termostato/umidostato/timer
    - incassato nella parte posteriore evita che sia a contatto con polvere, acqua, neve etc
- *Designed for applications in structures, tents, emergencies and mobile applications where the use of fossil fuels is not allowed*
  - *Extra strength elements AISI 321 for high performance*
  - *Set to be connected to an external thermostat*
  - *Selector switch (20 kW, 30 kW, 40 kW)*
  - *Power cord (0,5 m)*
  - *Swivelling wheels and lifting hooks*
  - *Pre heating and post cooling*
  - *Thermostat: FAN for fan control; OVERHEATING: safety thermostat in case of overheating, with manual reset*
  - *Stainless steel front and back grid*
  - *Possibility to stack-ability*
  - *Bearing structure with removable panels for internal washing, even on hanging machines*
  - *All installation inserts and screws are exclusively metric, not self-tapping*
  - *Centrifugal Fan IP 55:*
    - *very low noise fan (noise level  $\leq 67$ db at 2 meters)*
    - *high output, high performance fan guarantees increased air flow and static pressure for uniform and long distance diffusion of warm air through channels or ducts*
    - *very low noise fan (noise level  $\leq 67$ db at 2 meters)*
  - *Control rear electrical panel (IP 65):*
    - *can be connected to thermostat/humidistat/timer*
    - *integrated at the top rear of the machine to avoid contact with dust, water and snow*

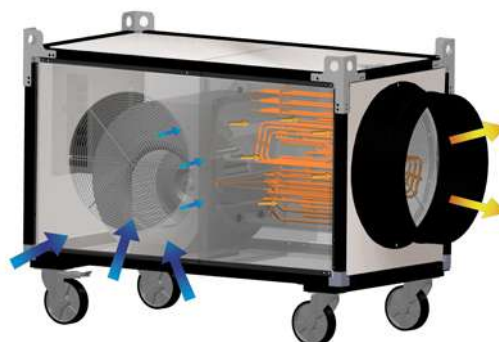



ACCESSORI A RICHIESTA / ACCESSORIES ON DEMAND

<p>KIT STAFFE INFORCOLAMENTO LIFTING KIT</p>	<p>RACCORDO 1 VIA ONE WAY ADAPTER</p>	<p>GUAINE FLESSIBILI IN PVC (l= 6m) CON CINGHIA DI FISSAGGIO FLEXIBLE AIR DUCTS (l= 6m) WITH CLIPS</p>
		<p>T MAX 100° C</p> 
<p>Cod. 06AC110                      €312,50</p>	<p>Mod. Ø 500 Cod. 02AC731                      €102,10</p>	<p>Mod. Ø 510 Cod. 02AC566                      €446,70</p>
<p>RACCORDO ASPIRAZIONE 1 VIA AIR INLET ADAPTER</p>	<p>GUAINE RINFORZATA PER RIPRESA ARIA (l= 6m) REINFORCED FLEXIBLE AIR INLET DUCT (l= 6m)</p>	<p>SPINA 5 POLI 5 PIN PLUG</p>
		
<p>Mod. Ø 500 Cod. 02AC731                      €102,10</p>	<p>Mod. Ø 510 Cod. 02AC795                      €447,90 Mod. Fascetta fissaggio guaina- clip for flexible duct (Ø 400-750 mm) Cod. 02AC663                      €11,70</p>	<p>Mod. 3P+⏚+N Cod. 06AC108 63A                      €107,50</p>
<p>TERMOSTATO AMBIENTE +5/+30°C CON CAVO (l= 10m) E SPINA 90° ROOM THERMOSTAT +5/+30°C WITH CABLE (l= 10m) AND PLUG 90°</p>	<p>TERMOSTATO AGRICOLTURA/CANTIERE -5/+50°C CON CAVO (l= 10m) E SPINA 90° HEAVY DUTY THERMOSTAT -5/+50°C WITH CABLE (l= 10m) AND PLUG 90°</p>	<p>TERMOSTATO ELETTRONICO DI PRECISIONE IP55 CON DISPLAY -10/+70°C SENZA CAVO E SPINA ELECTRONIC THERMOSTAT IP55 WITH DISPLAY -10/+70°C WITHOUT POWER CORD AND PLUG</p>
		
<p>Cod. 02AC581                      €49,30</p>	<p>Cod. 02AC582                      €98,80</p>	<p>Cod. 02AC294                      €186,40</p>

**EK T - GENERATORI MOBILI D'ARIA CALDA A CORRENTE ELTRICA CON VENTILATORE CENTRIFUGO**  
**ELECTRICAL MOBILE SPACE HEATERS WITH CENTRIFUGAL FAN**

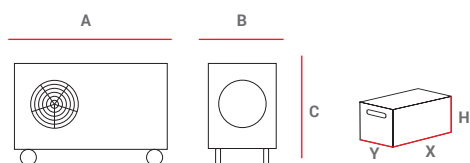

PESI E DIMENSIONI MACCHINA WEIGHTS AND DIMENSIONS MACHINE					IMBALLO PACKAGING			
MOD	A	B	C	Netto/Net	X	Y	H	Lordo/Gross
	[mm]	[mm]	[mm]	[kg]	[mm]	[mm]	[mm]	[kg]
EK T	1.270	660	967	132	1.400	720	905	144

		EK T
codice - code		06EK107
potenza term. nominale max max rated heat power	Hs [kW] Hs [ kcal/h - BTU/h ]	40 34.400 - 137.600
potenza term. nominale media medium rated heat power	Hs [kW] Hs [ kcal/h - BTU/h ]	30 25.800 - 103.200
potenza term. nominale min. min rated heat power	Hs [kW] Hs [ kcal/h - BTU/h ]	20 17.200 - 68.800
rendimento - heat efficiency	[ % ]	100
portata d'aria - air flow	[ m <sup>3</sup> /h ]	6.300
press. statica disponibile - available static pressure	mm H <sub>2</sub> O - Pa	20 - 200
salto termico - temperature rise	a 20°C [ °C ]	50 - 35
corrente massima - current max	[ A ]	60
alimentazione elettrica - electrical power	[ V - ph - Hz ]	400 - 3 - 50
connessioni - connections	[ n° ]	3P+N
quantità per pallet - pallet quantities	[ pz - pcs ]	1
<b>PREZZO - PRICE</b>	<b>EURO</b>	<b>3.375,00</b>

Possibilità di impilamento / Possibility to stack-ability



# AGRICOLTURA E ALLEVAMENTO *AGRICULTURE AND BREEDING*



## AGRICOLTURA E ALLEVAMENTO AGRICULTURE AND BREEDING

Fanno parte di questa famiglia i generatori di aria calda fissi o sospesi, dedicati alle applicazioni in agricoltura ed allevamento. Risolvono parecchi problemi di riscaldamento di strutture dove è decisiva l'economicità dell'investimento, quali serre ed allevamenti. Si tratta generalmente di prodotti dotati di ganci o staffe per l'installazione sospesa a soffitto e/o di basamento per l'installazione a terra su basi di sostegno. Possono avere un bruciatore integrato o separato. Per i primi sono sconsigliate le applicazioni in ambienti polverosi, sporchi e privi di ossigeno, mentre i secondi sono idonei in tali ambienti a patto che al bruciatore venga collegata una guaina mediante una presa snorkel per la presa dell'aria pulita dall'esterno. Fanno parte di questa famiglia:

*This family includes fix or suspended space heaters for agriculture and breeding applications. They solve numerous problems in heating structures such as greenhouses and stalls, where an inexpensive investment is a priority. In general, these heaters have hooks or brackets for installation on the ceiling and/or a support for installation on the ground.*

*The burner can be integrated or separate. Heaters with integrated burner are not recommended for use in spaces that are dusty, dirty, or low in oxygen, whereas those with separate burner can be used in these types of spaces provided a sheath is connected to the burner with a snorkel intake to pull in fresh air from the outside.*

*This family includes:*



**GE/S:** in acciaio verniciato, alimentati a gasolio, con bruciatore integrato, a combustione diretta: i residui della combustione vengono espulsi con l'aria calda prodotta dal generatore e contribuiscono al suo riscaldamento, per questo motivo hanno un rendimento del 100% ovvero trasformano tutta la potenza bruciata in potenza termica resa. Sono i più economici, anche per quel che riguarda l'esercizio ma per contro possono essere impiegati solamente in locali areati.

**GE/S:** in painted steel, diesel-fuelled, with integrated burner, direct combustion. Combustion residues are expelled with the hot air produced by the generator and contribute to its heating, making these heaters 100% efficient, i.e., they transform all of nominal input power into generated thermal power. They are the most economical models, including with regard to operation, but can be used only in ventilated rooms.



**EC/S:** in acciaio verniciato, alimentati a gasolio, con bruciatore integrato (EC) e separato (PHOEN) dal ventilatore, a combustione indiretta: impiegano uno scambiatore di calore che permette l'evacuazione dei fumi attraverso un camino collegabile con l'esterno; possono quindi essere collocati all'interno di locali chiusi, per contro hanno un costo più elevato ed un rendimento intorno al 90% dovendosi calcolare, in riduzione la quantità di calore evacuata attraverso il camino.

**EC/S:** in painted steel, diesel-fuelled, with integrated (EC) and separate (PHOEN) burner from ventilator, indirect combustion. These heaters have a heat exchanger that expels fumes through a chimney connected to the outside. Therefore, they can be operated in closed rooms. On the other hand, they have higher cost and efficiency of about 90% due to the heat lost through the chimney.



**GE AGRI:** in acciaio inox, alimentati a gasolio, con bruciatore integrato e combustione diretta possono essere facilmente pilotati da un unità di controllo esterna o collegati a un impianto di climatizzazione centralizzato. Hanno un rendimento del 100% ovvero trasformano tutta la potenza bruciata in potenza termica resa.

***GE AGRI:** in stainless steel, diesel-fuelled, with integrated burner and direct combustion can easily be driven by a remote control unit or connectable for climate computer. 100% efficient, i.e., they transform all of nominal input power into generated thermal power.*



**GA:** in acciaio inox per resistere meglio agli agenti corrosivi tipici degli allevamenti, alimentato a GPL in alta pressione (1,5 bar), con bruciatore integrato ed a combustione diretta. E' dotato di accensione automatica, grazie ad una apparecchiatura di controllo fiamma che consente il collegamento ad un termostato o climat computer per controllare accensione e spegnimento; è la macchina più economica per il riscaldamento di serre ed allevamenti.

***GA:** in stainless steel to resist corrosive agents typical of stalls, powered by high-pressure (1.5 bar) LPG, with integrated burner and direct combustion. Equipped with an automatic start thanks to a flame control unit that connects to a thermostat or climate computer that controls starting and stopping. This is the most economical heater for greenhouses and stalls.*



**GA/N:** in acciaio inox, alimentabili a GPL o metano in bassa pressione (20-30 mbar), con bruciatore integrato ed a combustione diretta. Possono essere facilmente pilotati da un unità di controllo esterna. A differenza del modello GA, funzionando a bassa pressione, possono essere sempre installati internamente, indipendentemente dalla normativa di riferimento in vigore.

***GA/N:** in stainless steel, can be powered by low-pressure LPG or methane (20-30 mbar), with integrated burner and direct combustion. Can easily be driven by a remote control unit. As opposed to the GA, these run at low pressure and can always be installed indoors regardless of the current regulations.*



**BH:** in acciaio inox, a combustione indiretta, dotati di bruciatore esterno, sono disponibili sia nella versione gasolio che nella versione GPL e metano. Di forma circolare, sono molto compatti ma al tempo stesso facilmente ispezionabili grazie alla particolare soluzione per l'accesso al bruciatore. Per tutti i modelli è prevista di serie l'attacco snorkel per la presa d'aria dall'ambiente esterno in modo tale da garantire una perfetta combustione.

***BH:** in stainless steel, indirect combustion, with external burner, in diesel version and in LPG/methane version. These round burners are very compact and easy to inspect thanks to a special method for reaching the burner. As standard, all models have a snorkel connection to pull in fresh air from the outside and ensure perfect combustion.*



**CH:** in acciaio zincato e verniciato a combustione indiretta, sono macchine di grandi dimensioni per ambienti più voluminosi. Possono montare indifferentemente un bruciatore esterno a gasolio, GPL o metano. Equipaggiate con ventilatore assiale sono un ottimo compromesso per rendimento (93%), e prevalenza. Consigliati in particolare per installazioni ove siano previste canalizzazioni o strutture di grande lunghezza.

**CH:** in galvanised and coated steel, with indirect combustion. These large units for high-volume spaces can be equipped with an external burner running on diesel, LPG, or methane. They are fit with a axial fan which ensures greater static pressure. Recommended for installations with ducts or in very long buildings.



**FARM:** in acciaio zincato, a combustione indiretta, installabili sia in posizione orizzontale che verticale sono macchine di grandi dimensioni per ambienti più voluminosi. Possono montare indifferentemente un bruciatore esterno a gasolio, GPL o metano. Equipaggiate con ventilatore assiale rispondente alle direttive ERP 2015 sono un ottimo compromesso per rendimento (93%), silenziosità e prevalenza. Consigliati in particolare per installazioni ove siano previste canalizzazioni o strutture di grande lunghezza.

**FARM:** in galvanised steel, with indirect combustion. These large units for high-volume spaces can install an external burner running on diesel, LPG, or methane, and are fit with a axial fan which, in addition to being very quiet, ensures greater pressure, a feature recommended for installations with ducts or in very long buildings.



**EK P:** alimentato a corrente elettrica. Infatti in sostituzione del bruciatore vi sono delle resistenze elettriche le quali garantiscono il riscaldamento dell'aria che viene convogliata mediante il ventilatore. Questa caratteristica li rende idonei all'impiego in qualsiasi condizione, per contro la potenza termica è limitata e vengono preferibilmente impiegati ove l'energia elettrica è disponibile a basso costo e dove vi sono superfici limitate da riscaldare.

**EK P:** powered by electricity. Instead of the burner they have electrical resistors that heat the air conveyed by the fan. This characteristic makes them suitable under all conditions, even in closed rooms. On the other hand, they have limited thermal power and are generally used where low-cost electrical energy is available and where there is a small area to be heated.



**FJ:** in acciaio inox, non sono generatori di aria calda bensì dei circolatori di aria. Vengono generalmente impegnati in abbinamento ai generatori per distribuire meglio il flusso di aria calda nell'ambiente da riscaldare.

**FJ:** in stainless steel. These ventilators are generally used together with heaters to ensure good distribution of hot air throughout the room.



# GE/S

GENERATORI D'ARIA CALDA SOSPESI A COMBUSTIONE DIRETTA  
*DIRECT COMBUSTION SUSPENDED SPACE HEATERS*





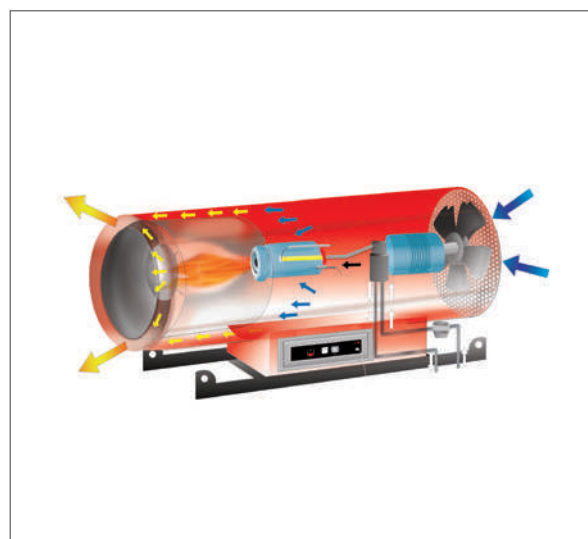

## GE/S - GENERATORI D'ARIA CALDA SOSPESI A COMBUSTIONE DIRETTA

- Bruciatore di gasolio integrato
  - Controllo elettronico di fiamma
  - Termostato di sicurezza
  - Presa per collegamento a termostato, umidostato o timer
  - Cavo alimentazione elettrica (1,5 m) con spina
  - Camera di combustione in acciaio inox AISI 430
  - Post-ventilazione temporizzata di raffreddamento della camera di combustione
  - Tubi alimentazione gasolio in gomma resistente agli idrocarburi con rivestimento in maglia rinforzante metallica
  - Quadro elettrico di comando (vedere pag. 20)
- *Build-in diesel burner*
  - *Electronic flame-control*
  - *Safety thermostat*
  - *Set to be connected to a thermostat or a humidistat or a timer*
  - *Power cord (1,5 m) with plug*
  - *AISI 430 stainless steel combustion chamber*
  - *Automatic post ventilation of unit*
  - *Fuel feed lines in hydrocarbon resistant rubber, whit a reinforced metal sheath*
  - *Electric control panel (see page 20)*



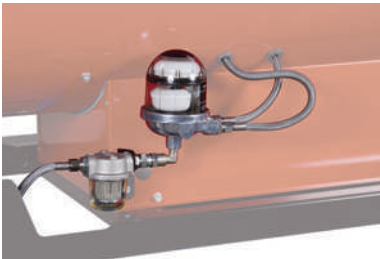

ACCESSORI A RICHIESTA / ACCESSORIES ON DEMAND

<p>TERMOSTATO AMBIENTE +5/+30°C CON CAVO L=10 m E SPINA 90° ROOM THERMOSTAT +5/+30°C CABLE 10 m, PLUG 90°</p>	<p>TERMOSTATO AGRICOLTURA/CANTIERE -5/+50°C CON CAVO L=10 m E SPINA 90° HEAVY DUTY THERMOSTAT -5/+50°C CABLE 10 m, PLUG 90°</p>	<p>TERMOSTATO ELETTRONICO DI PRECISIONE IP55 CON DISPLAY -10/+70°C SENZA CAVO E SPINA ELECTRONIC THERMOSTAT IP55 WITH DISPLAY -10/+70°C WITHOUT POWER CORD AND PLUG</p>
		
<p>Cod. 02AC581 €49,30</p>	<p>Cod. 02AC582 €98,80</p>	<p>Cod. 02AC294 €186,40</p>
<p>FILTRO GASOLIO RISCALDANTE PRE-HEATED FUEL FILTER</p>	<p>KIT COLLEGAMENTO SERBATOIO ESTERNO MONOTUBO CON DE-AERATORE SINGLE-PIPE EXTERNAL FUEL TANK CONNECTION KIT WITH DE-AERATOR</p>	<p>KIT COLLEGAMENTO BITUBO SERBATOIO ESTERNO GASOLIO (l= 5 m) + KIT ATTACCHI RAPIDI TWO-PIPE EXTERNAL FUEL TANK CONNECTION KIT (l=5 m) + QUICK CONNECTIONS KIT</p>
		
<p>Cod. 02AC548 €175,50</p>	<p>Cod. 02AC633 €215,50</p>	<p>Mod. Kit collegamento bitubo serbatoio esterno/ Two-pipe external tank connection kit Cod. 02AC668 €249,30 Mod. Kit attacchi rapidi (M+F x 2)/ Quick connections kit (M+F x 2) Cod. 02AC669 €68,00</p>
<p>FILTRO SEPARATORE ACQUA ANTI-WATER FILTER</p>		
		
<p>Cod. 02AC634 €106,30</p>		

## GE/S - GENERATORI D'ARIA CALDA SOSPESI A COMBUSTIONE DIRETTA DIRECT COMBUSTION SUSPENDED SPACE HEATERS

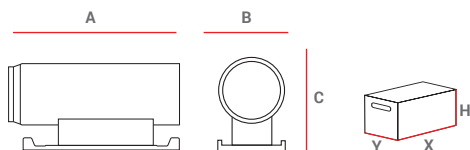

PESI E DIMENSIONI MACCHINA WEIGHTS AND DIMENSIONS MACHINE					IMBALLO PACKAGING			
MOD	A	B	C	Netto/Net	X	Y	H	Lordo/Gross
	[mm]	[mm]	[mm]	[kg]	[mm]	[mm]	[mm]	[kg]
GE 65/S	1.200	480	550	44	1.310	510	790	64
GE 105/S	1.418	567	694	72	1.690	620	875	97

		GE/S 65	GE/S 105
codice - code		02GE111	02GE110
potenza term. nominale - rated heat power	Hs [kW] Hs [kcal/h - BTU/h]	69,3 59.565 - 237.067	111,1 95.507 - 380.331
rendimento - heat efficiency	[ % ]	100	100
portata d'aria - air flow	[m³/h]	2500	4600
temperatura aria - air temperature	a 20°C [ °C ]	77	68
consumo - fuel consumption	[kg/h]	5,48	8,85
potenza elettrica - power consumption 230 V	[ W ]	598	1170
alimentazione elettrica - electrical power	[ V - ph - Hz ]	230 - 1 - 50	230 - 1 - 50
quantità per pallet - pallet quantities	[ pz - pcs ]	1	1
<b>PREZZO - PRICE</b>	<b>EURO</b>	<b>2.164,00</b>	<b>2.915,00</b>



# EC/S

GENERATORI MOBILI D'ARIA CALDA SOSPESI A COMBUSTIONE INDIRECTA  
*INDIRECT COMBUSTION SUSPENDED SPACE HEATERS*

## EC/S - GENERATORI MOBILI D'ARIA CALDA SOSPESI A COMBUSTIONE INDIRECTA

- Bruciatore di gasolio integrato
  - Presa per collegamento a termostato, umidostato o timer
  - Cavo alimentazione elettrica (1,5 m) con spina
  - Camera di combustione in acciaio inox AISI 430 a quattro giri di fumo (vedere pag. 24)
  - Post-ventilazione temporizzata di raffreddamento della camera di combustione
  - Controllo elettronico di fiamma
  - Termostato di sicurezza
  - Tubi alimentazione gasolio in gomma resistente agli idrocarburi con rivestimento in maglia rinforzante metallica
  - Quadro elettrico di comando (vedere pag. 20)
  - Adatti per applicazioni in serra, non per impianti avicoli o suinicoli
- *Build-in diesel burner*
  - *Set to be connected to a thermostat or a humidistat or a timer*
  - *Power cord (1,5 m) with plug*
  - *AISI 430 Stainless steel combustion chamber with four smoke revolutions (see pag. 24)*
  - *Automatic post ventilation of unit*
  - *Electronic flame-control*
  - *Safety thermostat*
  - *Fuel feed lines in hydrocarbon resistant rubber, with a reinforced metal sheath*
  - *Electric control panel (see page 20)*
  - *Suitable for greenhouse, not for livestock*

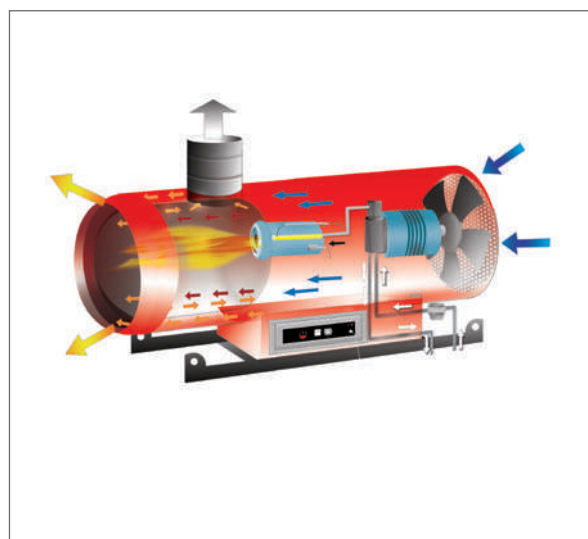

ACCESSORI A RICHIESTA / ACCESSORIES ON DEMAND

<p>TERMOSTATO AMBIENTE +5/+30°C CON CAVO L=10 m E SPINA 90° ROOM THERMOSTAT +5/+30°C CABLE 10 m, PLUG 90°</p>	<p>TERMOSTATO AGRICOLTURA/CANTIERE -5/+50°C CON CAVO L=10 m E SPINA 90° HEAVY DUTY THERMOSTAT -5/+50°C CABLE 10 m, PLUG 90°</p>	<p>TERMOSTATO ELETTRONICO DI PRECISIONE IP55 CON DISPLAY -10/+70°C SENZA CAVO E SPINA ELECTRONIC THERMOSTAT IP55 WITH DISPLAY -10/+70°C WITHOUT POWER CORD AND PLUG</p>
		
<p>Cod. 02AC581 €49,30</p>	<p>Cod. 02AC582 €98,80</p>	<p>Cod. 02AC294 €186,40</p>
<p>FILTRO GASOLIO RISCALDANTE PRE-HEATED FUEL FILTER</p>	<p>KIT COLLEGAMENTO SERBATOIO ESTERNO MONOTUBO CON DE-AERATORE SINGLE-PIPE EXTERNAL FUEL TANK CONNECTION KIT WITH DE-AERATOR</p>	<p>KIT COLLEGAMENTO BITUBO SERBATOIO ESTERNO GASOLIO (l= 5 m) + KIT ATTACCHI RAPIDI TWO-PIPE EXTERNAL FUEL TANK CONNECTION KIT (l=5 m) + QUICK CONNECTIONS KIT</p>
		
<p>Cod. 02AC548 €175,50</p>	<p>Cod. 02AC633 €215,50</p>	<p>Mod. Kit collegamento bitubo serbatoio esterno/ Two-pipe external tank connection kit Cod. 02AC668 €249,30 Mod. Kit attacchi rapidi (M+F x 2)/ Quick connections kit (M+F x 2) Cod. 02AC669 €68,00</p>
<p>FILTRO SEPARATORE ACQUA ANTI-WATER FILTER</p>	<p>CONVERSA PASS PLATE</p>	<p>TUBO SCARICO FUMI INOX (L = 1 m) STAINLESS STEEL EXHAUST PIPE (L = 1 m)</p>
		
<p>Cod. 02AC634 €106,30</p>	<p>Mod. Ø 150 mm Cod. 02AC432 €31,90</p>	<p>Mod. Ø 150 mm Cod. 02AC285 €69,10</p>

## EC/S - GENERATORI MOBILI D'ARIA CALDA SOSPESI A COMBUSTIONE INDIRECTA INDIRECT COMBUSTION SUSPENDED SPACE HEATERS

CURVA A 90° SCARICO FUMI IN INOX STAINLESS STEEL EXHAUST ELBOW	TERMINALE PER CAMINO IN INOX STAINLESS STEEL CHIMNEY POT
	
<b>Mod. Ø 150 mm</b> <b>Cod. 02AC288</b> <p style="text-align: right;"><b>€57,20</b></p>	<b>Mod. Ø 150 mm</b> <b>Cod. 02AC282</b> <p style="text-align: right;"><b>€54,60</b></p>

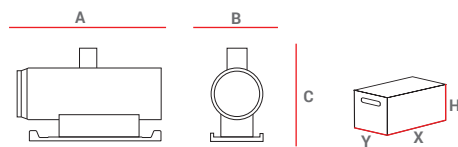

PESI E DIMENSIONI MACCHINA WEIGHTS AND DIMENSIONS MACHINE				IMBALLO PACKAGING				
MOD	A	B	C	Netto/Net	X	Y	H	Lordo/Gross
	[mm]	[mm]	[mm]	[kg]	[mm]	[mm]	[mm]	[kg]
EC/S 55	1.400	480	605	67	1.310	510	800	80
EC/S 85	1.650	590	720	96	1.690	620	880	121

		EC/S 55	EC/S 85
codice - code		02EC106	02EC107
potenza term. nominale - rated heat power	Hs [kW] Hs [kcal/h - BTU/h]	58,6 50.434 - 200.728	90,6 77.934 - 310.177
potenza term. resa - output heat power	Hs [kW] Hs [kcal/h - BTU/h]	52,5 45.139 - 179.652	80,2 68.972 - 274.507
rendimento - heat efficiency	[ % ]	89,5	88,5
portata d'aria - air flow	[m <sup>3</sup> /h]	2500	4300
salto termico - temperature rise	a 20°C [ °C ]	66	77
consumo - fuel consumption	[kg/h]	4,64	7,17
potenza elettrica - power consumption 230V	[ W ]	850	1140
alimentazione elettrica - electrical power	[ V - ph - Hz ]	230 - 1 - 50	230 - 1 - 50
Ø camino - Ø flue	[mm]	150	150
Ø guaina uscita aria - Ø outlet hose	1 - 2 vie [mm]	350 - 300	400 - 300
quantità per pallet - pallet quantities	[ pz - pcs ]	1	1
<b>PREZZO - PRICE</b>	<b>EURO</b>	<b>2.653,00</b>	<b>3.249,00</b>



# GE 125 AGRI

GENERATORI D'ARIA CALDA PENSILI A COMBUSTIONE DIRETTA  
*DIRECT COMBUSTION SUSPENDED SPACE HEATERS*

## GE 125 AGRI - GENERATORI D'ARIA CALDA PENSILI A COMBUSTIONE DIRETTA

- Bruciatore di gasolio integrato
- Quadro elettrico IP 65
- Presa per collegamento a termostato, umidostato o timer
- Struttura esterna ed interna in acciaio inox AISI 430
- Accensione automatica
- Controllo elettronico di fiamma
- Termostato di sicurezza
- Predisposizione per collegamento ad impianto centralizzato di climatizzazione
- Monitoraggio pressione aria del ventilatore con switch IP 65 a paletta
- Pompa gasolio a ingranaggi
- Tubi alimentazione gasolio in gomma resistente agli idrocarburi con rivestimento in maglia rinforzante metallica
- Post-ventilazione continua (ventilatore sempre acceso) o temporizzata (90 secondi)
- Commutatore inverno-estate per utilizzo come ventilatore
- Conforme alle normative UNI EN 13842:2005
- Ganci di sospensione
- *Build-in diesel burner*
- *Electric board IP 65*
- *Set to be connected to a room thermostat or a humidistat or a timer*
- *High-grade AISI 430 stainless steel design*
- *Automatic ignition*
- *Electronic flame-control*
- *Overheating thermostat*
- *Connectable for climate computer*
- *Monitoring the fan air pressure by a vane switch IP 65*
- *Gearbox pump*
- *Fuel feed lines in hydrocarbon resistant rubber, with a reinforced metal sheath*
- *Continue post ventilation (fan always switch on) or temporized post ventilation (90 seconds)*
- *Summer-winter switch to use as a fan*
- *In conformity to UNI EN 13842:2005*
- *Suspending brackets*

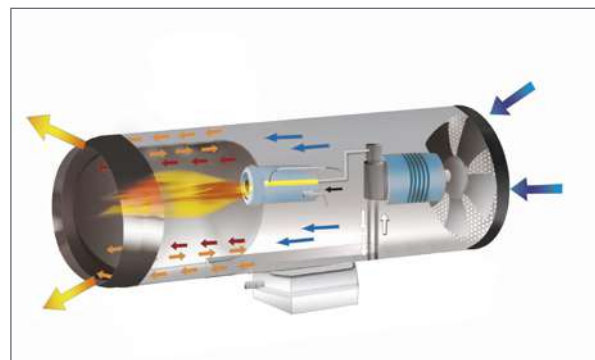







SERBATOIO OPZIONALE - OPTIONAL TANK





ACCESSORI A RICHIESTA / ACCESSORIES ON DEMAND

<p>TERMOSTATO AGRICOLTURA/CANTIERE -5/+50°C CON CAVO L=10 m E SPINA 90° HEAVY DUTY THERMOSTAT -5/+50°C CABLE 10 m, PLUG 90°</p>	<p>TERMOSTATO ELETTRONICO DI PRECISIONE IP55 CON DISPLAY -10/+70°C SENZA CAVO E SPINA ELECTRONIC THERMOSTAT IP55 WITH DISPLAY -10/+70°C WITHOUT POWER CORD AND PLUG</p>	<p>KIT SERBATOIO CON RUOTE E MANIGLIA WHEELS AND HANDLE TANK KIT</p>
		
<p>Cod. 02AC582                      €98,80</p>	<p>Cod. 02AC294                      €186,40</p>	<p>Mod. 135 litri/litres Cod. 99AC117                      €866,50</p>
<p>INDICATORE DI LIVELLO FUEL LEVEL GAUGE</p>	<p>FILTRO GASOLIO RISCALDANTE PRE-HEATED FUEL FILTER</p>	<p>KIT COLLEGAMENTO SERBATOIO ESTERNO MONOTUBO CON DE-AERATORE SINGLE-PIPE EXTERNAL FUEL TANK CONNECTION KIT WITH DE-AERATOR</p>
		
<p>Cod. 02AC510                      €57,60</p>	<p>Cod. 02AC548                      €175,50</p>	<p>Cod. 02AC633                      €215,50</p>
<p>KIT COLLEGAMENTO BITUBO SERBATOIO ESTERNO GASOLIO (l= 5 m) + KIT ATTACCHI RAPIDI TWO-PIPE EXTERNAL FUEL TANK CONNECTION KIT (l=5 m) + QUICK CONNECTIONS KIT</p>		
		
<p>Mod. Kit collegamento bitubo serbatoio esterno/ Two-pipe external tank connection kit Cod. 02AC668                      €249,30 Mod. Kit attacchi rapidi (M+F x 2)/ Quick connections kit (M+F x 2) Cod. 02AC669                      €68,00</p>		

## GE 125 AGRI - GENERATORI D'ARIA CALDA PENSILI A COMBUSTIONE DIRETTA DIRECT COMBUSTION SUSPENDED SPACE HEATERS

		<b>GE 125 AGRI</b>
codice - code		02GE112
potenza term. nominale - rated heat power	Hs [kW] Hs [kcal/h - BTU/h]	125,76 108.151 - 432.604
potenza term. resa - output heat power	Hs [kW] Hs [kcal/h - BTU/h]	125,76 108.151 - 432.604
consumo - fuel consumption	[kg/h]	9,95
rendimento - heat efficiency	[ % ]	100
portata d'aria - air flow	[ m³/h ]	8300
potenza elettrica - power consumption 230V	[ W/A ]	1080/5,3
alimentazione elettrica - electrical power	[ V - ph - Hz ]	230 - 1 - 50
rumore - noise level	[ dBA a 62m ]	71
campo di lavoro effettivo - effective heat range	[ m ]	62
quantità per pallet - pallet quantities	[ pz - pcs ]	1
<b>PREZZO - PRICE</b>	<b>EURO</b>	<b>3.264,00</b>

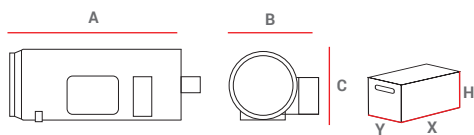

<b>PESI E DIMENSIONI MACCHINA WEIGHTS AND DIMENSIONS MACHINE</b>					<b>IMBALLO PACKAGING</b>			
MOD	A	B	C	Netto/Net	X	Y	H	Lordo/Gross
	[mm]	[mm]	[mm]	[kg]	[mm]	[mm]	[mm]	[kg]
GE 125 AGRI	1.515	740	644	72	1.590	800	800	97



# GA



GENERATORI D'ARIA CALDA PENSILI IN MEDIA PRESSIONE A COMBUSTIONE DIRETTA  
DIRECT COMBUSTION MEDIUM PRESSURE SUSPENDED SPACE HEATERS

## GA - GENERATORI D'ARIA CALDA PENSILI IN MEDIA PRESSIONE A COMBUSTIONE DIRETTA

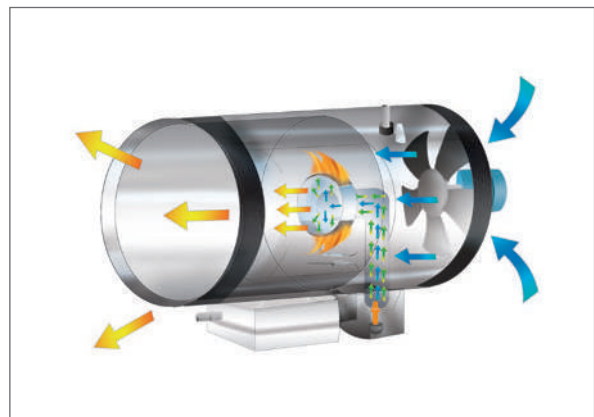
- Bruciatore GPL automatico incorporato a bassissime emissioni di CO, NOx e di Etilene
- Quadro elettrico IP 65
- Presa per collegamento a termostato, umidostato o timer
- Struttura esterna ed interna in acciaio inox AISI 430
- Accensione automatica
- Controllo di fiamma con rilevazione a ionizzazione
- Termostato di sicurezza
- Predisposizione per collegamento ad impianto centralizzato di climatizzazione
- Monitoraggio pressione aria del ventilatore con switch IP 65 a paletta
- Motore IP55 installato a vista per facile manutenzione e pulizia e libero da surriscaldamenti
- Post-ventilazione continua (ventilatore sempre acceso) o temporizzata (30 secondi)
- Commutatore inverno-estate per utilizzo come ventilatore
- Conforme alle normative UNI EN 12669:2003 e UNI EN 1596:2008
- Ganci di sospensione
- Controllo di bassa tensione
- Built-in LPG burner to give very low emissions of CO, NOx and Ethylene
- Electric board IP 65
- Set to be connected to a thermostat or a humidistat or a timer
- High-grade AISI 430 stainless steel design
- Automatic ignition
- Flame monitored by an ionisation electrode
- Overheating thermostat
- Connectable to external climate computer
- Monitoring the fan air pressure by a vane switch IP 65
- IP 55 motor installed in a easy clean position to avoid overheating
- Possibility to control winter ventilation from external climate computer
- Dedicated switch to swap from winter heating mode to summer ventilation mode
- Conforms to norms UNI EN 12669:2003 and UNI EN 1596:2008
- Integrated suspending hooks
- Low voltage control



ACCESSORI IN DOTAZIONE / SUPPLIED ACCESSORIES





TUBO GAS CON RACCORDI (1,5 m) GAS HOSE WITH CONNECTIONS (1,5 m)	RIDUTTORI DI PRESSIONE PRESSURE REDUCERS			
				A <b>Tipo/Type</b> Regolabile/Adjust. <b>Bar</b> :Pin 2 ÷ 16 bar Pout 1,5 ÷ 0,4 bar <b>Cod.</b> T30332-D
Cod. I40554	ADATTATORI / ADAPTORS			
	1 - Paese/Country	2 - Paese/Country	3 - Paese/Country	4 - Paese/Country
	AT/BG/CY/DK/DE/EE/LT/LV/ MK/MT/RO/TR/NL/RU	NL	IT/GR/AL	BE/CZ/ES/FR/HR/HU/LU/PL/ PT/SI/SK/MA/RU
	Cod. T30528	Cod. T30529	Cod. T30527	

ACCESSORI A RICHIESTA / ACCESSORIES ON DEMAND

<b>TERMOSTATO AMBIENTE +5/+30°C CON CAVO L=10 m E SPINA 90° ROOM THERMOSTAT +5/+30°C CABLE 10 m, PLUG 90°</b>	<b>TERMOSTATO AGRICOLTURA/CANTIERE -5/+50°C CON CAVO L=10 m E SPINA 90° HEAVY DUTY THERMOSTAT -5/+50°C CABLE 10 m, PLUG 90°</b>	<b>TERMOSTATO ELETTRONICO DI PRECISIONE IP55 CON DISPLAY -10/+70°C SENZA CAVO E SPINA ELECTRONIC THERMOSTAT IP55 WITH DISPLAY -10/+70°C WITHOUT POWER CORD AND PLUG</b>
		
Cod. 02AC581 €49,30	Cod. 02AC582 €98,80	Cod. 02AC294 €186,40
<b>CONTROLLO REMOTO PER SINGOLA MACCHINA SINGLE UNIT REMOTE CONTROL</b>	<b>KIT TEMPORIZZATORE PER ACCENSIONE MACCHINE CON TEMPI DIFFERITI E SEQUENZIALI DELAYED AND SEQUENTIAL STARTING RELAY</b>	<b>KIT SNORKEL PER PRESA ARIA PULITA DALL'ESTERNO MEDIANTE COLLEGAMENTO GUAINA FRESH AIR INTAKE DUCT ADAPTER</b>
		
Cavo/Cable 5m Cod. 02AC584 €131,90	Cod. 02AC586 €167,10	Mod. (Ø 100 mm) Cod. 02AC535 €65,80 Mod. Guaina/Duct 5 m (Ø 100 mm) Cod. 02AC577 €140,40
<b>PASSAPARETE SNORKEL SNORKEL PASS-PLATE</b>	<b>VALVOLA DI SICUREZZA STOP GAS STOP GAS VALVE</b>	<b>TUBO GAS CON RACCORDI L= 3 m GAS HOSE WITH CONNECTIONS L= 3 m</b>
		
Mod. Ø 100 mm Cod. 02AC793 €87,90	Cod. 03AC504 €23,30	Cod. 03AC511 €16,80

# GA - GENERATORI D'ARIA CALDA PENSILI IN MEDIA PRESSIONE A COMBUSTIONE DIRETTA

## DIRECT COMBUSTION MEDIUM PRESSURE SUSPENDED SPACE HEATERS

FILTRO GAS GAS FILTER	ADATTATORI PER REGOLATORE LPG ADAPTORS	
	 A	A Cod. 03AC508 €13,70 Страна/Country NO/SE/USA/CA/MEX/AUS/NZ/RA
	 B	B Cod. 03AC507 €13,70 Страна/Country GB/FI/IS
	 C	C Cod. 03AC509 €6,90 Страна/Country BR
	 D	D Cod. 03AC510 €6,90 Страна/Country CH/NL
Cod. 03AC524 €64,20		

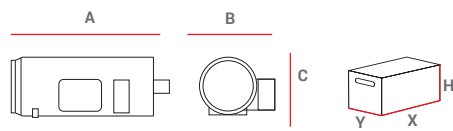

PESI E DIMENSIONI MACCHINA WEIGHTS AND DIMENSIONS MACHINE					IMBALLO PACKAGING			
MOD	A	B	C	Netto/Net	X	Y	H	Lordo/Gross
	[mm]	[mm]	[mm]	[kg]	[mm]	[mm]	[mm]	[kg]
GA 100 C	1.146	589	441	36	1.190	605	490	41

		GA 100 C
codice - code		03GA112
potenza term. nominale max max rated heat power	Hs [kW] Hs [kcal/h - BTU/h]	100,38 86.324 - 345.295
potenza term. nominale min. min rated heat power	Hs [kW] Hs [kcal/h - BTU/h]	47,42 40.782 - 163.127
consumo gas max - max fuel consumption	[m³/h - kg/h]	12,68 - 6,683
consumo gas min - min fuel consumption	[m³/h - kg/h]	6,0 - 3,156
pressione gas - gas pressure	[bar]	0,4 - 1,5
rendimento - heat efficiency	[%]	100
portata d'aria - air flow	[m³/h]	5.100
temperatura aria - air temperature	a 20°C [°C]	75
potenza elettrica - power consumption 230V	[W]	600
alimentazione elettrica - electrical power	[V - ph - Hz]	230 - 1 - 50
quantità per pallet - pallet quantities	[pz - pcs]	8
<b>PREZZO - PRICE</b>	<b>EURO</b>	<b>1.896,00</b>

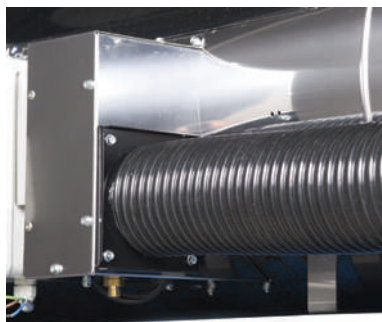

### Kit snorkel

Mediante l'utilizzo di tale accessorio l'unità aspira aria pulita dall'ambiente esterno garantendo una perfetta e costante combustione anche in presenza di ambienti molto polverosi.

### Snorkel kit

With this accessory the unit draws clean air from the outside to ensure a perfect and constant combustion, even in very dusty environments.



**NEW**

**GA/N**

GENERATORI D'ARIA CALDA PENSILI IN BASSA PRESSIONE A COMBUSTIONE DIRETTA  
*DIRECT COMBUSTION LOW PRESSURE SUSPENDED SPACE HEATERS*

## GA/N - GENERATORI D'ARIA CALDA PENSILI IN BASSA PRESSIONE A COMBUSTIONE DIRETTA

- Bruciatore GPL o metano automatico incorporato a bassissime emissioni di CO, NOx e di Etilene
- Quadro elettrico IP 65
- Presa per collegamento a termostato, umidostato o timer
- Struttura esterna ed interna in acciaio inox AISI 430
- Accensione automatica
- Controllo di fiamma con rilevazione a ionizzazione
- Termostato di sicurezza
- Predisposizione per collegamento ad impianto centralizzato di climatizzazione
- Monitoraggio pressione aria del ventilatore con switch IP 65 a paletta
- Rampa gas in scatola stagna IP65
- Motore IP55 installato a vista per facile manutenzione e pulizia e libero da surriscaldamenti
- Post-ventilazione continua (ventilatore sempre acceso) o temporizzata (30 secondi)
- Commutatore inverno-estate per utilizzo come ventilatore
- Conforme alle normative UNI EN 17082:2019
- Ganci di sospensione
- Controllo di bassa tensione
- Selettore di potenza 95-115 kW (GA/N 115)
- Automatic built-in LPG o natural gas burner to give very low emissions of CO, NOx and Ethylene
- Electric board IP 65
- Set to be connected to a thermostat or a humidistat or a timer
- High-grade AISI 430 stainless steel design
- Automatic ignition
- Flame monitored by an ionisation probe
- Overheating thermostat
- Connectable for climate computer
- Monitoring the fan air pressure by a vane switch IP 65
- Gas train in IP65 sealed box
- IP 55 motor installed in a easy clean position to avoid overheating
- Continue post ventilation (fan always switch on) or temporized post ventilation (30 seconds)
- Summer-winter switch to use as a fan
- Conforms to norms UNI EN 17082:2019
- Suspending brackets
- Low voltage control
- Power selector 95-115 kW (GA/N 115)

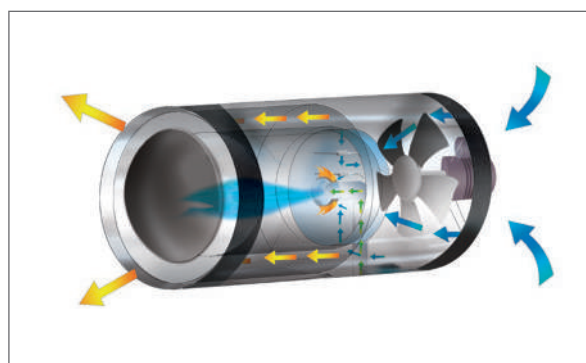



ACCESSORI A RICHIESTA / ACCESSORIES ON DEMAND

<p>TERMOSTATO AMBIENTE +5/+30°C CON CAVO L=10 m E SPINA 90° ROOM THERMOSTAT +5/+30°C CABLE 10 m, PLUG 90°</p>	<p>TERMOSTATO AGRICOLTURA/CANTIERE -5/+50°C CON CAVO L=10 m E SPINA 90° HEAVY DUTY THERMOSTAT -5/+50°C CABLE 10 m, PLUG 90°</p>	<p>TERMOSTATO ELETTRONICO DI PRECISIONE IP55 CON DISPLAY -10/+70°C SENZA CAVO E SPINA ELECTRONIC THERMOSTAT IP55 WITH DISPLAY -10/+70°C WITHOUT POWER CORD AND PLUG</p>
		
<p>Cod. 02AC581 €49,30</p>	<p>Cod. 02AC582 €98,80</p>	<p>Cod. 02AC294 €186,40</p>
<p>CONTROLLO REMOTO PER SINGOLA MACCHINA SINGLE UNIT REMOTE CONTROL</p>	<p>KIT TEMPORIZZATORE PER ACCENSIONE MACCHINE CON TEMPI DIFFERITI E SEQUENZIALI DELAYED AND SEQUENTIAL STARTING RELAY</p>	<p>RESISTENZA PTC ANTICONDENSA SU TESTA BRUCIATORE ANTI-MOISTURE PTC THERMISTOR RESISTENCE ON COMBUSTION HEAD</p>
		
<p>Mod. GA/N 45 (Cavo/Cable 3m) Cod. 02AC621 €131,90</p> <p>Mod. GA/N 70/95/115 (Cavo/Cable 5m) Cod. 02AC584 €131,90</p>	<p>Mod. GA/N 70/95/115 Cod. 02AC586 €167,10</p>	<p>Cod. 02AC587 €204,60</p>
<p>KIT REGOLATORE GAS CON FILTRO GAS REGULATOR KIT WITH FILTER (P.in MAX 6 bar)</p>	<p>FILTRO REGOLATORE GAS GAS FILTER REGULATOR (P.in MAX 2 bar)</p>	<p>FILTRO GAS GAS FILTER (P.in MAX 2 bar)</p>
		
<p>Mod. GPL - LPG (DN 25 3/4" or 1") (P.out set. 30mbar) Cod. 03AC619 €211,80</p>	<p>Mod. GAS METANO - NATURAL GAS (DN 25 3/4" or 1") (P.out set. 20mbar) Cod. 03AC617 €158,60</p> <p>Mod. GPL - LPG (DN 25 3/4" or 1") (P.out set. 30mbar) Cod. 03AC618 €158,60</p>	<p>Mod. GA/N 45 (DN 20 - 3/4") Cod. 03AC600 €29,90</p> <p>Mod. GA/N 70/95/115 (DN 25 - 1") Cod. 03AC603 €53,40</p>
<p>KIT VALVOLA MASSIMA PRESSIONE MAX GAS PRESSURE PROTECTION VALVE KIT (200 mbar)</p>	<p>TUBO GAS MEDIA PRESSIONE (l= 3 m) + VALVOLA CHIUSURA + RACCORDI COLLEGAMENTO MEDIUM PRESSURE GAS HOSE (l= 3 m) + GAS VALVE + CONNECTIONS (P. MAX 5 bar)</p>	<p>TUBO GAS BASSA PRESSIONE (l= 2 m) + VALVOLA CHIUSURA + RACCORDI COLLEGAMENTO LOW PRESSURE GAS HOSE (l= 2 m) + GAS VALVE + CONNECTIONS (P.in MAX 0,5 bar)</p>
		
<p>Mod. G 3/4" Cod. 03AC620 €78,20</p>	<p>Mod. GA/N 45 Tubo/Hose gas 3/4" Cod. 03AC614 €337,80</p> <p>Mod. GA/N 70/95/115 Tubo/Hose gas 1" Cod. 03AC615 €423,70</p>	<p>Mod. GA/N 45 Tubo/Hose gas 3/4" Cod. 03AC611 €199,80</p> <p>Mod. GA/N 70/95/115 Tubo/Hose gas 1" Cod. 03AC612 €256,70</p>

# GA/N - GENERATORI D'ARIA CALDA PENSILI IN BASSA PRESSIONE A COMBUSTIONE DIRETTA DIRECT COMBUSTION LOW PRESSURE SUSPENDED SPACE HEATERS

		GA/N 45 C	GA/N 70 C	GA/N 95 C	GA/N 115 C
codice - code		03GA521	03GA531	03GA541	03GA551
potenza term. nominale (min) metano G20 min rated heat power nat. gas G20	Hs [kW] Hs [kcal/h - BTU/h]	-	-	-	95,07 81.757 - 327.027
potenza term. nominale (max) metano G20 max rated heat power nat. gas G20	Hs [kW] Hs [kcal/h - BTU/h]	45,64 39.254 - 157.015	71,27 61.296 - 245.183	97,09 83.497 - 333.989	116,64 100.311 - 401.244
pressione alim. - inlet pressure G20	[mbar]	20	20	20	20
consumo gas - fuel consumption G20	[m³/h]	4,084	6,574	8,885	10,888
potenza term. nominale (min) GPL G31 min rated heat power LPG G31	Hs [kW] Hs [kcal/h - BTU/h]	-	-	-	94,18 80.996 - 323.984
potenza term. nominale (max) GPL G31 max rated heat power LPG G31	Hs [kW] Hs [kcal/h - BTU/h]	43,82 37.689 - 150.756	70,26 60.426 - 241.705	96,75 83.208 - 332.832	113,86 97.920 - 391.678
pressione alim. - inlet pressure G31	[mbar]	30/37	30/37	30/37	30/37
consumo gas - fuel consumption G31	[m³/h - kg/h]	1,532 - 3,13	2,569 - 5,02	3,561 - 6,91	4,170 - 8,13
rendimento - heat efficiency	[%]	100	100	100	100
portata d'aria - air flow	[m³/h]	2.500	4.700	6.700	8.700
temperatura aria - air temperature	a 20°C [°C]	55	43	48	50
distanza effettiva di riscaldamento effective heat range	[m]	40	42	45	47
potenza elettrica - power consumption 230V	[W]	250	400	630	980
alimentazione elettrica - electrical power	[V - ph - Hz]	230 - 1 - 50	230 - 1 - 50	230 - 1 - 50	230 - 1 - 50
quantità per pallet - pallet quantities	[pz - pcs]	10	1	1	1
<b>PREZZO - PRICE</b>	<b>EURO</b>	<b>1.841,00</b>	<b>2.278,00</b>	<b>2.397,00</b>	<b>3.305,00</b>

PESI E DIMENSIONI MACCHINA WEIGHTS AND DIMENSIONS MACHINE					IMBALLO PACKAGING			
MOD	A	B	C	Netto/Net	X	Y	H	Lordo/Gross
	[mm]	[mm]	[mm]	[kg]	[mm]	[mm]	[mm]	[kg]
GA/N 45 C	850	475	351	21	815	495	385	24
GA/N 70 C	1.146	596	441	46	1.190	660	624	61
GA/N 95 C	1.146	596	441	46	1.190	660	624	61
GA/N 115 C	1.200	689	530	56	1.240	750	718	74

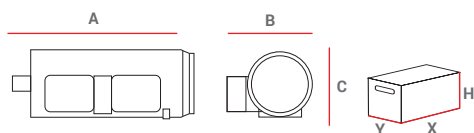

## Quadro elettrico - Electrical control board

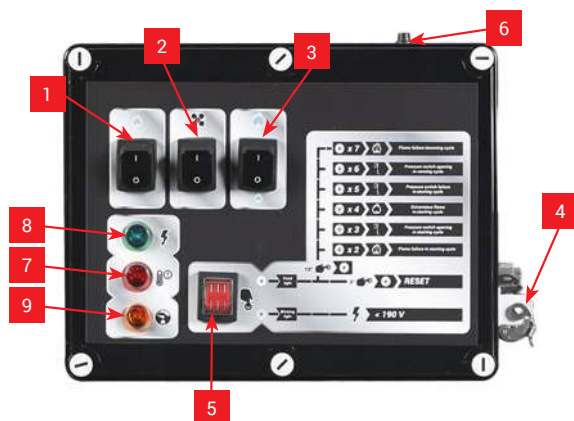

### Legenda

- 1 Interruttore bruciatore
- 2 Interruttore ventilatore
- 3 Selettore di potenza (GA/N 115)
- 4 Presa e spina per termostato ambiente
- 5 Pulsante di reset con spia rossa di blocco/diagnostica/bassa tensione
- 6 Termostato di surriscaldamento a riarmo manuale
- 7 Spia rossa intervento termostato di surriscaldamento
- 8 Spia di presenza tensione
- 9 Spia mancanza gas

### Legend

- 1 Burner switch
- 2 Fan switch
- 3 Power selector (GA/N 115)
- 4 Remote thermostat plug
- 5 Reset button with red block / diagnostics/ low voltage
- 6 Overheating thermostat reset button
- 7 Red light - operation of overheating thermostat
- 8 Alert light - presence of current
- 9 No gas warning light



# BH







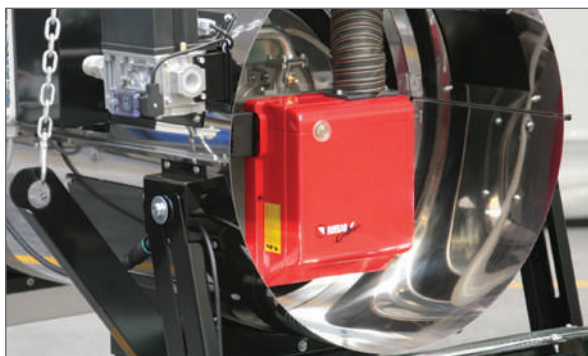
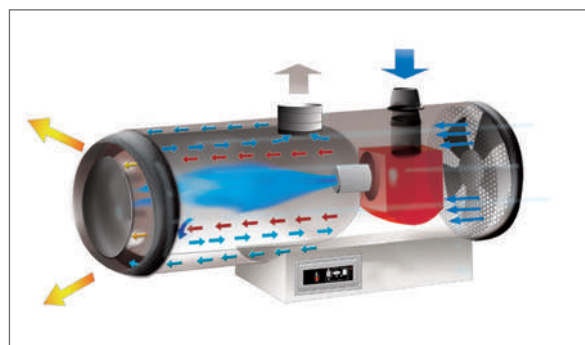

GENERATORI D'ARIA CALDA PENSILI A COMBUSTIONE INDIRECTA  
*INDIRECT COMBUSTION SUSPENDED SPACE HEATERS*

## BH - GENERATORI D'ARIA CALDA PENSILI A COMBUSTIONE INDIRECTA

- Struttura interna ed esterna in acciaio inox AISI 430
- Bruciatore automatico separato a gasolio o a gas
- Ribaltamento ventilatore per facile manutenzione-sostituzione del bruciatore
- Controllo elettronico di fiamma
- Termostato automatico di FAN per ventilare solo aria calda, con il pre-riscaldamento della camera di combustione e post-ventilazione di raffreddamento
- Termostato automatico di LIMIT per il controllo del bruciatore
- Termostato OVERHEATING di surriscaldamento a riarmo manuale
- Commutatore inverno-estate per utilizzo come ventilatore
- Pressostati di sicurezza (aria e gas)
- Camera di combustione in acciaio inox AISI 430 a quattro giri di fumo
- Quadro elettrico protezione IP65
- Possibilità di interfaccia con termostato, umidostato o timer
- Predisposizione per collegamento ad impianto centralizzato di climatizzazione
- Rampa gas: gruppo valvole completo di filtro gas, regolatore di pressione, elettrovalvola di sicurezza, elettrovalvola di lavoro ad apertura lenta, stabilizzatore, prese di pressione.
- Completo di attacco snorkel di serie per presa aria di combustione pulita dall'esterno
- *High-grade AISI 430 stainless steel body and combustion chamber*
- *Automatic oil or NATURAL / LPG gas separate burner*
- *Tipping fan for easy burner maintenance or replacement*
- *Electronic control flame box*
- *FAN automatic thermostat for hot air blowing, with combustion chamber pre-warming and after cooling cycle*
- *LIMIT automatic thermostat to control the burner*
- *Safety OVERHEATING manual reset thermostat*
- *Summer-winter switch to use as a fan*
- *Air and gas safety pressure switches*
- *Four smoke loops AISI 430 stainless steel combustion chamber*
- *IP65 electric board grade protection*
- *Connectable to a thermostat, humidistat or timer*
- *Connectable to a climate computer*
- *Gas train: gas safety box with gas filter, pressure reducer, safety solenoid valve, slow action work solenoid valve, stabilizer, gas pressure connections*
- *Snorkel connection adapter to allow outside clean combustion air feed*

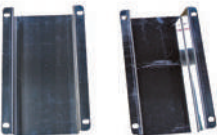

ACCESSORI A RICHIESTA / ACCESSORIES ON DEMAND

<p>TERMOSTATO AMBIENTE +5/+30°C CON CAVO L=10 m E SPINA 90° ROOM THERMOSTAT +5/+30°C CABLE 10 m, PLUG 90°</p>	<p>TERMOSTATO AGRICOLTURA/CANTIERE -5/+50°C CON CAVO L=10 m E SPINA 90° HEAVY DUTY THERMOSTAT -5/+50°C CABLE 10 m, PLUG 90°</p>	<p>TERMOSTATO ELETTRONICO DI PRECISIONE IP55 CON DISPLAY -10/+70°C SENZA CAVO E SPINA ELECTRONIC THERMOSTAT IP55 WITH DISPLAY -10/+70°C WITHOUT POWER CORD AND PLUG</p>
		
<p>Cod. 02AC581                      €49,30</p>	<p>Cod. 02AC582                      €98,80</p>	<p>Cod. 02AC294                      €186,40</p>
<p>CONTROLLO REMOTO PER SINGOLA MACCHINA SINGLE UNIT REMOTE CONTROL</p>	<p>KIT TEMPORIZZATORE PER ACCENSIONE MACCHINE CON TEMPI DIFFERITI E SEQUENZIALI DELAYED AND SEQUENTIAL STARTING RELAY</p>	<p>KIT DI SOSPENSIONE SUSPENSION KIT</p>
		
<p>Cod. 02AC626                      €131,90 (Cavo/Cable 5m)</p>	<p>Cod. 02AC586                      €167,10</p>	<p>Mod. BH 50 Cod. 02AC639                      €77,40 Mod. BH 100 Cod. 02AC641                      €98,20</p>
<p>KIT DI INFORCAMENTO FORK LIFT ADAPTER KIT</p>	<p>FILTRO GASOLIO RISCALDANTE PRE-HEATED FUEL FILTER</p>	<p>KIT COLLEGAMENTO SERBATOIO ESTERNO MONOTUBO CON DE-AERATORE SINGLE-PIPE EXTERNAL FUEL TANK CONNECTION KIT WITH DE-AERATOR</p>
		
<p>Mod. BH 50 Cod. 02AC640                      €63,30</p>	<p>Cod. 02AC548                      €175,50</p>	<p>Cod. 02AC633                      €215,50</p>
<p>Mod. BH 100 Cod. 02AC642                      €83,80</p>		

<b>FILTRO SEPARATORE ACQUA ANTI-WATER FILTER</b>	<b>KIT COLLEGAMENTO BITUBO SERBATOIO ESTERNO GASOLIO (l= 5 m) + KIT ATTACCHI RAPIDI TWO-PIPE EXTERNAL FUEL TANK CONNECTION KIT (l=5 m) + QUICK CONNECTIONS KIT</b>	<b>PASSAPARETE SNORKEL + GUAINA FLESSIBILE SNORKEL PASS PLATE + FLEXIBLE DUCT</b>
		
<b>Cod. 02AC634</b> <b>€106,30</b>	<b>Mod. Kit collegamento bitubo serbatoio esterno/ Two-pipe external tank connection kit</b> <b>Cod. 02AC668</b> <b>€249,30</b>  <b>Mod. Kit attacchi rapidi (M+F x 2)/ Quick connections kit (M+F x 2)</b> <b>Cod. 02AC669</b> <b>€68,00</b>	<b>Mod. Ø 100 mm</b> <b>Cod. 02AC793</b> <b>€87,90</b>  Guaina/Duct 5 m Ø 100mm <b>Cod. 02AC577</b> <b>€140,40</b>
<b>KIT REGOLATORE GAS CON FILTRO GAS REGULATOR KIT WITH FILTER (P.in MAX 6 bar)</b>	<b>FILTRO REGOLATORE GAS GAS FILTER REGULATOR (P.in MAX 2 bar)</b>	<b>FILTRO GAS GAS FILTER (P.in MAX 2 bar)</b>
		
<b>Mod. GPL - LPG (DN 25 3/4" or 1") (P.out set. 30mbar)</b> <b>Cod. 03AC619</b> <b>€211,80</b>	<b>Mod. GAS METANO - NATURAL GAS (DN 25 3/4" or 1") (P.out set. 20mbar)</b> <b>Cod. 03AC617</b> <b>€158,60</b>  <b>Mod. GPL - LPG (DN 25 3/4" or 1") (P.out set. 30mbar)</b> <b>Cod. 03AC618</b> <b>€158,60</b>	<b>Mod. BH 50 (DN 20 - 3/4")</b> <b>Cod. 03AC600</b> <b>€29,90</b>  <b>Mod. BH 100 (DN 25 - 1")</b> <b>Cod. 03AC603</b> <b>€53,40</b>
<b>KIT VALVOLA MASSIMA PRESSIONE MAX GAS PRESSURE PROTECTION VALVE KIT (200 mbar)</b>	<b>TUBO GAS MEDIA PRESSIONE (l= 3 m) + VALVOLA CHIUSURA + RACCORDI COLLEGAMENTO MEDIUM PRESSURE GAS HOSE (l= 3 m) + GAS VALVE + CONNECTIONS (P. MAX 5 bar)</b>	<b>TUBO GAS BASSA PRESSIONE (l= 2 m) + VALVOLA CHIUSURA + RACCORDI COLLEGAMENTO LOW PRESSURE GAS HOSE (l= 2 m) + GAS VALVE + CONNECTIONS (P.in MAX 0,5 bar)</b>
		
<b>Mod. G 3/4"</b> <b>Cod. 03AC620</b> <b>€78,20</b>	<b>Mod. BH 50 Tubo/Hose gas 3/4"</b> <b>Cod. 03AC614</b> <b>€337,80</b>  <b>Mod. BH 100 Tubo/Hose gas 1"</b> <b>Cod. 03AC615</b> <b>€423,70</b>	<b>Mod. BH 50 Tubo/Hose gas 3/4"</b> <b>Cod. 03AC611</b> <b>€199,80</b>  <b>Mod. BH 100 Tubo/Hose gas 1"</b> <b>Cod. 03AC612</b> <b>€256,70</b>

CONVERSA PASS PLATE	TUBO SCARICO FUMI INOX L = 1 m STAINLESS STEEL EXHAUST PIPE L = 1 m	CURVA A 90° SCARICO FUMI IN INOX STAINLESS STEEL EXHAUST ELBOW
		
<p>Mod. Ø 150 mm Cod. 02AC432</p> <p style="text-align: right;"><b>€31,90</b></p>	<p>Mod. Ø 150 mm Cod. 02AC285</p> <p style="text-align: right;"><b>€69,10</b></p>	<p>Mod. Ø 150 mm Cod. 02AC288</p> <p style="text-align: right;"><b>€57,20</b></p>
TERMINALE PER CAMINO IN INOX STAINLESS STEEL CHIMNEY POT	KIT ANTICONDENSA DRAINING KIT	KIT CAMINO E SNORKEL CHIMNEY AND SNORKEL KIT
		
<p>Mod. senza rete - w/out mesh (Ø 150 mm) Cod. 02AC657</p> <p style="text-align: right;"><b>€54,60</b></p>	<p>Mod. Ø 150 mm raccordo a T - T connection Cod. 02AC459</p> <p style="text-align: right;"><b>€79,90</b></p>	<p>Mod. Ø 150 mm Cod. 02AC918</p> <p style="text-align: right;"><b>€1.1356,90</b></p>
<p>Mod. con rete - with mesh (Ø 150 mm) Cod. 02AC680</p> <p style="text-align: right;"><b>€73,50</b></p>	<p>Mod. Ø 150 mm terminale anticondensa - antiwater chimney pot Cod. 02AC460</p> <p style="text-align: right;"><b>€56,90</b></p>	

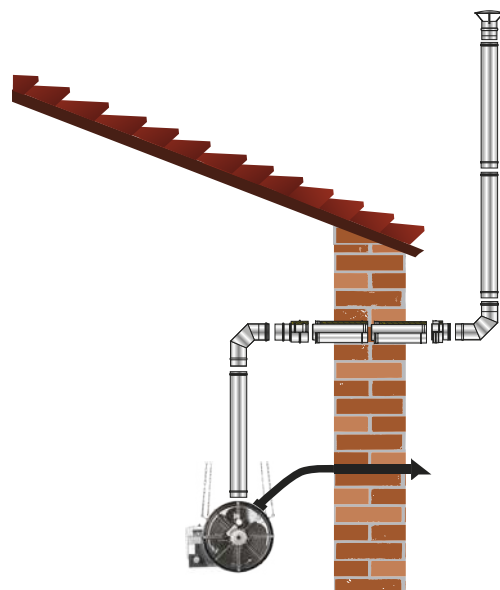

## BH - GENERATORI D'ARIA CALDA PENSILI A COMBUSTIONE INDIRECTA INDIRECT COMBUSTION SUSPENDED SPACE HEATERS

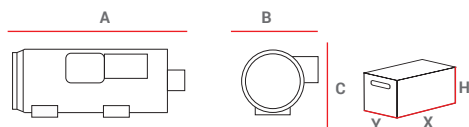

PESI E DIMENSIONI MACCHINA WEIGHTS AND DIMENSIONS MACHINE					IMBALLO PACKAGING			
MOD	A	B	C	Netto/Net	X	Y	H	Lordo/Gross
	[mm]	[mm]	[mm]	[kg]	[mm]	[mm]	[mm]	[kg]
BH 50	1.379	670	630	75	1.430	750	718	100
BH 100	1.781	804	776	135	1.830	895	900	153

		BH 50 (GASOLIO-OIL)	BH 50 (METANO-NATURAL GAS)	BH 50 (GPL-LPG)
codice - code		02BH101	02BH101M	02BH101G
potenza term. nominale - rated heat power	Hs [kW] Hs [kcal/h - BTU/h]	49,8 42.869 - 170.619	50,08 43.073 - 172.291	49,98 42.979 - 171.916
potenza term. resa - output heat power	Hs [kW] Hs [kcal/h - BTU/h]	44,4 38.152 - 151.851	45,08 38.766 - 155.062	45,23 38.896 - 155.584
rendimento - heat efficiency	[ % ]	89	90	90,5
portata d'aria - air flow	[m <sup>3</sup> /h]	4.100	4.100	4.100
salto termico - temperature rise	a 20°C [ °C ]	50	54	54
consumo gasolio - oil consumption	[kg/h]	3,94	-	-
consumo metano - natural gas consumption G20	[ m <sup>3</sup> /h ]	-	4,554	-
pressione alim. - inlet pressure G20	[ mbar ]	-	20	-
consumo GPL - LPG consumption G31	[ m <sup>3</sup> /h - kg/h ]	-	-	1,830 - 3,67
pressione alim. - inlet pressure G31	[ mbar ]	-	-	30/37
potenza elettrica - power consumption 230V	[ W ]	750	800	800
alimentazione elettrica - electrical power	[ V - ph - Hz ]	230 - 1 - 50	230 - 1 - 50	230 - 1 - 50
∅ camino - ∅ flue	[mm]	150	150	150
quantità per pallet - pallet quantities	[ pz - pcs ]	1	1	1
<b>PREZZO - PRICE</b>	<b>EURO</b>	<b>3.219,00</b>	<b>3.767,00</b>	<b>3.767,00</b>

		BH 100 (GASOLIO-OIL)	BH 100 (METANO-NATURAL GAS)	BH 100 (GPL-LPG)
codice - code		02BH102	02BH102M	02BH102G
potenza term. nominale - rated heat power	Hs [kW] Hs [kcal/h - BTU/h]	99,8 85.869 - 341.757	94,63 81.382 - 325.527	97,89 84.187 - 336.749
potenza term. resa - output heat power	Hs [kW] Hs [kcal/h - BTU/h]	89,9 77.282 - 307.581	85,36 73.406 - 293.625	88,30 75.937 - 303.474
rendimento - heat efficiency	[ % ]	90	90,2	90,2
portata d'aria - air flow	[m <sup>3</sup> /h]	7.500	7.500	7.500
salto termico - temperature rise	a 20°C [ °C ]	55	53	53
consumo gasolio - oil consumption	[kg/h]	7,9	-	-
consumo metano - natural gas consumption G20	[ m <sup>3</sup> /h ]	-	8,684	-
pressione alim. - inlet pressure G20	[ mbar ]	-	20	-
consumo GPL - LPG consumption G31	[ m <sup>3</sup> /h - kg/h ]	-	-	3,549 - 7,12
pressione alim. - inlet pressure G31	[ mbar ]	-	-	30/37
potenza elettrica - power consumption 230V	[ W ]	1.000	1.200	1.200
alimentazione elettrica - electrical power	[ V - ph - Hz ]	230 - 1 - 50	230 - 1 - 50	230 - 1 - 50
∅ camino - ∅ flue	[mm]	150	150	150
quantità per pallet - pallet quantities	[ pz - pcs ]	1	1	1
<b>PREZZO - PRICE</b>	<b>EURO</b>	<b>4.101,00</b>	<b>4.722,00</b>	<b>4.722,00</b>





**NEW**

**CH**

GENERATORI D'ARIA CALDA PENSILI A GRANDE PORTATA A COMBUSTIONE INDIRECTA  
INDIRECT COMBUSTION HEAVY DUTY SUSPENDED SPACE HEATERS

## CH - GENERATORI D'ARIA CALDA PENSILI A GRANDE PORTATA A COMBUSTIONE INDIRETTA

- Progettato per applicazioni nel settore Agricolo, Avicolo, suini e serre
- Struttura esterna in acciaio resistente alla corrosione e camera di combustione in acciaio inox
- Efficienza termica > 91%
- Bruciatore dotato di presa snorkel per garantire aria di combustione pulita mediante collegamento con guaina di aspirazione aria all' esterno
- Pre riscaldamento e Post ventilazione della camera di combustione
- Vetrino di ispezione camera di combustione
- Quadro elettrico con grado di protezione IP 68:
  - collegabile a termostato/umidostato/timer
  - possibilità di collegamento a unità di controllo centralizzata mediante morsetti cablata
- Robusti ganci di sospensione in acciaio inox per installazione a soffitto e piedi di appoggio in acciaio inox per trasporto e installazione a pavimento
- Ventilatore:
  - molto silenzioso ( rumore < 69 db a 1 metro)
  - 7 pale: alte prestazioni (portata d'aria e pressione statica) per la diffusione omogenea dell'aria calda mediante guaina perforata
  - grado di protezione IP55
  - boccaglio ventilatore per convogliare l'aria e garantire alta pressione statica
- *Designed for agricultural and horticultural applications: poultry, pigs and greenhouses*
- *External structure in corrosion resistant steel and combustion chamber in stainless steel*
- *Heat efficiency > 91%*
- *Burner is supplied with snorkel outlet to ensure clean combustion air through connection with external air aspiration duct*
- *Combustion chamber with pre heating and after cooling cycles*
- *Combustion chamber inspection glass peep-hole*
- *IP68 electric box:
 
  - connectable to room thermostat/humidistat/timer
  - connectable to a central control unit through wired terminal*
- *Sturdy suspension hooks in stainless steel for ceiling installation and support feet in stainless steel for handling and floor installation*
- *Fan:
 
  - very low-noise fan (noise level less than 69 db at 1 meter)
  - with 7 blades: high performances (air flow and static pressure) for uniform diffusion of warm air through the perforated duct
  - protection class IP55
  - air inlet cone to ensure high static pressure*

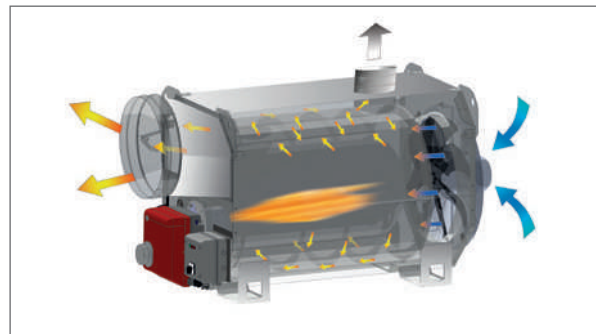

Scatola termostati con presa rapida: FAN per il controllo ventilatore; LIMIT per il controllo del bruciatore; OVERHEATING termostato di sicurezza in caso di surriscaldamento con riarmo manuale.

Thermostat with quick connection socket: FAN for fan control; LIMIT for burner control; OVERHEATING safety thermostat in case of overheating, with manual reset.

ACCESSORI A RICHIESTA / ACCESSORIES ON DEMAND

<p>TERMOSTATO AGRICOLTURA/CANTIERE -5/+50°C CON CAVO L=10 m E SPINA 90° HEAVY DUTY THERM. -5/+50°C CABLE 10 m, PLUG 90°</p>	<p>TERMOSTATO ELETTRONICO DI PRECISIONE IP55 CON DISPLAY -10/+70°C SENZA CAVO E SPINA ELECTRONIC THERMOSTAT IP55 WITH DISPLAY -10/+70°C WITHOUT POWER CORD AND PLUG</p>	<p>PASSAPARETE SNORKEL + GUAINA FLESSIBILE SNORKEL PASS PLATE + FLEXIBLE DUCT</p>
		
<p>Cod. 02AC582                      €98,90</p>	<p>Cod. 02AC294                      €186,40</p>	<p>Mod. (Ø 100 mm) Cod. 02AC793                      €87,90 Mod. Guaina /Duct (Ø 100 mm, l=5m) Cod. 02AC577                      €140,40</p>
<p>BRUCIATORE GASOLIO RIELLO RIELLO DIESEL BURNER</p>	<p>BRUCIATORE RIELLO GPL + RAMPA GAS LPG RIELLO BURNER + GAS TRAIN</p>	<p>BRUCIATORE RIELLO METANO + RAMPA GAS NATURAL GAS RIELLO BURNER + GAS TRAIN</p>
		
<p>Mod. CH 100 DIESEL/OIL Cod. 076B101-10                      €968,00 Mod. CH 135 DIESEL/OIL Cod. 076B103                      €1.221,00</p>	<p>Mod. CH 135 GPL/LPG Cod. 074B103-15                      €2.276,00</p>	<p>Mod. CH 135 METANO/NATURAL GAS Cod. 074B104-15                      €2.276,00</p>
<p>KIT COLLEGAMENTO MONOTUBO CON FILTRO SINGLE PIPE EXTERNAL FUEL TANK CONNECTION KIT WITH DEAERATOR</p>	<p>FILTRO SEPARATORE ACQUA ANTI-WATER FILTER</p>	<p>CONVERSA CHIMNEY PASS-PLATE</p>
		
<p>Cod. 02AC800                      €215,50</p>	<p>Cod. 02AC801                      €106,30</p>	<p>Mod. (Ø 200 mm) Cod. 02AC412                      €32,40</p>
<p>CURVA A 90° SCARICO FUMI IN INOX STAINLESS STEEL EXHAUST ELBOW</p>	<p>TUBO SCARICO FUMI INOX (L = 1 m) STAINLESS STEEL EXHAUST PIPE (L = 1 m)</p>	<p>TERMINALE PER CAMINO IN INOX STAINLESS STEEL CHIMNEY POT</p>
		
<p>Mod. (Ø 200 mm) Cod. 02AC290                      €64,30</p>	<p>Mod. (Ø 200 mm) Cod. 02AC287                      €83,60</p>	<p>Mod. (Ø 200 mm) Cod. 02AC658                      €59,80</p>

# CH - GENERATORI D'ARIA CALDA PENSILI A GRANDE PORTATA A COMBUSTIONE INDIRETTA INDIRECT COMBUSTION HEAVY DUTY SUSPENDED SPACE HEATERS

RACCORDO 1 VIA ONE WAY ADAPTER		PROLUNGA RIDUZIONE TEMPERATURA PER GUAINA PREFORATA IN PVC PREFORATED PVC FLEXIBLE AIR DUCT EXTENSION		FASCETTA FISSAGGIO GUAINA MANDATA E RIPRESA ARIA CLIP FOR FLEXIBLE AIR INLET/OUTLET DUCT	
					
Mod. (Ø 500 mm) Cod. 02AC690	€177,20	Mod. (Ø 505 mm l=1,5 m) Cod. 02AC809	€132,80	Mod. (Ø 400-750 mm) Cod. 02AC663	€11,70
Mod. (Ø 600 mm) Cod. 02AC691	€194,90	Mod. (Ø 605 mm l=1,5 m) Cod. 02AC810	€140,30		
KIT FISSAGGIO GUAINA PREFORATA IN PVC PREFORATED PVC FLEXIBLE AIR DUCT HANGING KIT			GUAINE PREFORATE PREFORATED DUCT		
				Mod. 25 m (1 via/1 way) Ø 500 mm Cod. 02AC771	€650,10
Mod. (cavo/cable 45m + ganci/hooks) Cod. 02AC789	€112,50			Mod. 25 m (1 via/1 way) Ø 600 mm Cod. 02AC776	€680,30
Mod. (cavo/cable 70m + ganci/hooks) Cod. 02AC790	€170,70			Mod. 50 m (1 via/1 way) Ø 500 mm Cod. 02AC772	€1.300,10
Mod. (cavo/cable 120m + ganci/hooks) Cod. 02AC791	€276,00			Mod. 50 m (1 via/1 way) Ø 600 mm Cod. 02AC777	€1.360,70
				Mod. 100 m (1 via/1 way) Ø 500 mm Cod. 02AC773	€2.600,30
				Mod. 100 m (1 via/1 way) Ø 600 mm Cod. 02AC778	€2.722,50

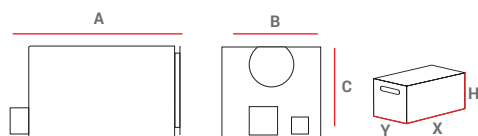

PESI E DIMENSIONI MACCHINA WEIGHTS AND DIMENSIONS MACHINE					IMBALLO PACKAGING			
MOD	A	B	C	Netto/Net	X	Y	H	Lordo/Gross
	[mm]	[mm]	[mm]	[kg]	[mm]	[mm]	[mm]	[kg]
CH 100	1.718	851	963	190	1.890	880	1.110	210
CH 135	1.718	851	963	190	1.890	880	1.110	210

		CH 100 (OIL)	CH 135 (OIL-GAS)
codice - code		02CH111	02CH101
potenza term. nominale - rated heat power	Hs [kW] Hs [kcal/h - BTU/h]	98,48 84.695 - 338.779	133,97 115.216 - 460.864
potenza term. resa - output heat power	Hs [kW] Hs [kcal/h - BTU/h]	92,87 79.867 - 319.468	121,91 104.847 - 419.387
rendimento - heat efficiency	[ % ]	94,30	91
portata d'aria - air flow	[m³/h]	11.000	11.000
pressione statica disponibile - available static pression	[Pa - mm H <sub>2</sub> O]	200-20	200-20
salto termico - temperature rise	a 20°C [ °C ]	35	45
campo di lavoro effettivo - effective heat range	[m]	43	43
consumo gasolio - oil consumption	[kg/h]	7,79	10,60
consumo metano - natural gas consumption G20	[m³/h]	-	12,74
pressione alimentazione - inlet pressure G20	[mbar]	-	20,00
consumo GPL - GPL consumption G31	[m³/h - kg/h]	-	4,93-9,59
pressione alimentazione - inlet pressure G31	[mbar]	-	37,00
alimentazione elettrica - electrical power	[V - ph - Hz]	230/400 - 3 - 50	230/400 - 3 - 50
potenza elettrica - power consumption	[W]	2.020	2.020
Ø camino - Ø flue	[mm]	200	200
quantità per pallet - pallet quantities	[ pz - pcs ]	1	1
<b>PREZZO - PRICE</b>	<b>EURO</b>	<b>3.938,00</b>	<b>3.938,00</b>

\* Macchina senza bruciatore ed uscita aria - Machine without burner and air adapter



# FARM

GENERATORI D'ARIA CALDA PENSILI A GRANDE PORTATA A COMBUSTIONE INDIRECTA  
*INDIRECT COMBUSTION HEAVY DUTY SUSPENDED SPACE HEATERS*

## FARM - GENERATORI D'ARIA CALDA PENSILI A GRANDE PORTATA A COMBUSTIONE INDIRETTA

- La macchina può essere installata in posizione orizzontale o verticale
  - Bruciatore dotato di presa snorkel per garantire aria di combustione pulita mediante collegamento con guaina di aspirazione aria all'esterno
  - Il nuovo scambiatore di calore abbinato ai nuovi ventilatori di maggiori prestazioni permettono di ottenere un rendimento termico del 92 ÷ 93%
  - Pre riscaldamento e Post ventilazione camera di combustione
  - Vetrino di ispezione camera di combustione
  - Termostati: FAN per il controllo ventilatore; LIMIT per il controllo del bruciatore; OVERHEATING termostato di sicurezza in caso di surriscaldamento con riarmo manuale.
  - Pannelli con pieghe di rinforzo a croce per garantire maggior rigidità e robustezza
  - Struttura portante con pannelli rimovibili per il lavaggio interno, anche a macchina appesa
  - Utilizzo esclusivamente di viti e inserti metrici per il fissaggio, no viti autofilettanti
  - Ventilatore:
    - rispondente alle direttive ERP 2015
    - molto silenzioso ( rumore < 69 db a 1 metro)
    - 7 pale: alte prestazioni (portata d'aria e pressione statica) per la diffusione omogenea dell'aria calda mediante guaina preforata
    - grado di protezione IP55
    - boccaglio ventilatore per convogliare l'aria e garantire alta pressione statica
  - Quadro elettrico:
    - collegabile a termostato/umidostato/timer
    - possibilità di collegamento a unità di controllo centralizzata mediante morsettiera cablata
  - Ciascun componente principale (ventilatore, bruciatore, quadro elettrico, termostati, etc.) è munito di connessioni rapide di collegamento elettrico IP68:
    - velocità di montaggio/smontaggio e di intervento tecnico
    - eliminazione di errori di installazione/smontaggio
  - Robusti ganci di sospensione in acciaio inox per installazione a soffitto e piedi di appoggio in acciaio inox per installazione a pavimento
- *The unit can be installed horizontally or vertically,*
  - *Burner is supplied with snorkel outlet to ensure clean combustion air through connection with external air aspiration duct*
  - *The new heat exchanger combined with the new high-performance fans allow for heat output of 92 / 93%*
  - *Before heating and after cooling of combustion chamber*
  - *Combustion chamber inspection glass peep-hole*
  - *Thermostat: FAN for fan control; LIMIT: for burner control; OVERHEATING: safety thermostat in case of overheating, with manual reset*
  - *Panels with reinforcement cross fold to ensure higher rigidity and strength*
  - *Bearing structure with removable panels for internal washing, even on hanging machines*
  - *All installation inserts and screws are exclusively metric, not self-tapping*
  - *Fan:*
    - *in compliance with directive ERP 2015*
    - *extremely low-noise fan (noise level less than 69 db at 1 meter)*
    - *with 7 blades: high performance (air flow and static pressure) for uniform diffusion of warm air through the perforated duct*
    - *insulation class IP55*
    - *fan inlet to carry the air and ensure high static pressure*
  - *Electric switchboard:*
    - *can be connected to thermostat/humidistat/timer*
    - *Can be connected to a central control unit through wired terminal*
  - *Each main component (fan, burner, electrical switchboard, thermostats, etc.) is supplied with quick couplings of electrical connections IP68:*
    - *quick assembly and disassembly and technical interventions*
    - *elimination of installation and disassembly errors*
  - *Sturdy suspension hooks in stainless steel for ceiling installation and support feet in stainless steel for floor installation*

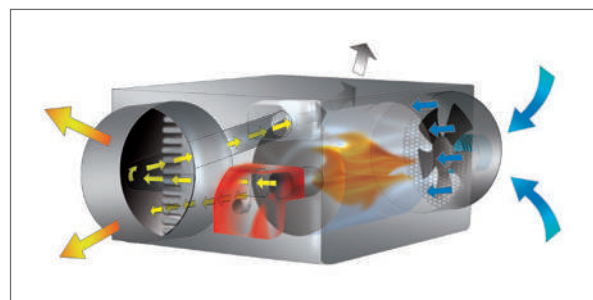











ACCESSORI A RICHIESTA / ACCESSORIES ON DEMAND

RACCORDO 1 VIA ONE WAY ADAPTER	PANNELLO UNA VIA LATERALE ONE WAY SIDE PANEL
	
<p>Mod. FARM 85 (Ø 450 mm) Cod. 02AC721</p>	<p>Mod. FARM 85 Cod. 02AC722</p>
<p>Mod. FARM 110 (Ø 500 mm) Cod. 02AC731</p>	<p>Mod. FARM 110 Cod. 02AC732</p>
<p>Mod. FARM 145 (Ø 600 mm) Cod. 02AC741</p>	<p>Mod. FARM 145 Cod. 02AC742</p>
<p>Mod. FARM 185 (Ø 650 mm) Cod. 02AC751</p>	<p>Mod. FARM 185 Cod. 02AC752</p>
<p>Mod. FARM 235 (Ø 700 mm) Cod. 02AC761</p>	<p>Mod. FARM 235 Cod. 02AC762</p>
PANNELLO CON RACCORDO 2 VIE LATERALE SIDE PANEL WITH TWO WAYS ADAPTER	KIT CARRELLO (SOLO PER INSTALLAZIONE VERTICALE) TROLLEY KIT (ONLY FOR VERTICAL INSTALLATION)
	
<p>Mod. FARM 85 (Ø 400 mm) Cod. 02AC723</p>	<p>Mod. FARM 85 Cod. 02AC725</p>
<p>Mod. FARM 110 (Ø 400 mm) Cod. 02AC733</p>	<p>Mod. FARM 110 Cod. 02AC735</p>
<p>Mod. FARM 145 (Ø 500 mm) Cod. 02AC743</p>	<p>Mod. FARM 145 Cod. 02AC745</p>
<p>Mod. FARM 185 (Ø 500 mm) Cod. 02AC753</p>	<p>Mod. FARM 185 Cod. 02AC755</p>
<p>Mod. FARM 235 (Ø 600 mm) Cod. 02AC763</p>	<p>Mod. FARM 235 Cod. 02AC765</p>

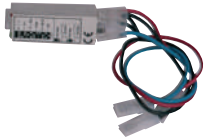
## FARM - GENERATORI D'ARIA CALDA PENSILI A GRANDE PORTATA A COMBUSTIONE INDIRETTA

BRUCIATORE GASOLIO RIELLO <i>RIELLO DIESEL BURNER</i>	BRUCIATORE RIELLO GPL+RAMPA GAS <i>LPG RIELLO BURNER+GAS TRAIN</i>	BRUCIATORE RIELLO METANO+RAMPA GAS <i>NATURAL GAS RIELLO BURNER+GAS TRAIN</i>
		
Mod. FARM 85 DIESEL/OIL Cod. 076B101 €879,00	Mod. FARM 85 GPL/LPG Cod. 074B101-01 €2.008,00	Mod. FARM 85 METANO/NATURAL GAS Cod. 074B102-01 €2.008,00
Mod. FARM 110 DIESEL/OIL Cod. 076B102 €968,00	Mod. FARM 110/145 GPL/LPG Cod. 074B103-01 €2.276,00	Mod. FARM 110/145 METANO/NATURAL GAS Cod. 074B104-01 €2.276,00
Mod. FARM 145 DIESEL/OIL Cod. 076B103 €1.221,00	Mod. FARM 185 GPL/LPG Cod. 074B103-02 €2.276,00	Mod. FARM 185 METANO/NATURAL GAS Cod. 074B104-02 €2.276,00
Mod. FARM 185 DIESEL/OIL Cod. 076B104 €1.221,00	Mod. FARM 235 GPL/LPG Cod. 074B105-03 €2.893,00	Mod. FARM 235 METANO/NATURAL GAS Cod. 074B106-03 €2.893,00
Mod. FARM 235 DIESEL/OIL Cod. 076B105 €1.274,00		
BRUCIATORE GASOLIO ECOFLAM <i>ECOFLAM DIESEL BURNER</i>	KIT SNORKEL PER PRESA ARIA PULITA DALL'ESTERNO MEDIANTE COLLEGAMENTO GUAINA <i>SNORKEL KIT FOR ECOFLAM BURNER</i>	PASSAPARETE SNORKEL + GUAINA FLESSIBILE <i>SNORKEL PASS PLATE + FLEXIBLE DUCT</i>
		
Mod. FARM 85 DIESEL/OIL Cod. 072B111 €879,00	Mod. FARM 85/110 (Ø 80/100 mm) ECOFLAM Cod. 02AC602 €79,00	Mod. FARM 85/110/145/185 (Ø 100 mm) Cod. 02AC793 €87,90
Mod. FARM 110 DIESEL/OIL Cod. 072B112 €968,00	Mod. FARM 145/185/235 (Ø 100 mm) ECOFLAM Cod. 02AC603 €158,60	Mod. FARM 235 (Ø 150 mm) Cod. 02AC794 €95,60
Mod. FARM 145 DIESEL/OIL Cod. 072B113 €1.221,00		Mod. Guaina/Duct FARM 85/110/145/185 RIELLO/ECOFLAM (Ø 100 mm, l=5m) Cod. 02AC577 €140,40
Mod. FARM 185 DIESEL/OIL Cod. 072B114 €1.221,00		Mod. Guaina/Duct FARM 235 RIELLO (Ø 150 mm, l=5m) Cod. 02AC792 €163,40
Mod. FARM 235 DIESEL/OIL Cod. 072B115 €1.274,00		
TERMOSTATO AMBIENTE +5/+30°C CON CAVO L=10 m E SPINA 90° <i>ROOM THERMOSTAT +5/+30°C CABLE 10 m, PLUG 90°</i>	TERMOSTATO AGRICOLTURA/CANTIERE -5/+50°C CON CAVO L=10 m E SPINA 90° <i>HEAVY DUTY THERM. -5/+50°C CABLE 10 m, PLUG 90°</i>	TERMOSTATO ELETTRONICO DI PRECISIONE IP55 CON DISPLAY -10/+70°C SENZA CAVO E SPINA <i>ELECTRONIC THERMOSTAT IP55 WITH DISPLAY -10/+70°C WITHOUT POWER CORD AND PLUG</i>
		
Cod. 02AC581 €49,30	Cod. 02AC582 €98,80	Cod. 02AC294 €186,40
FILTRO GASOLIO RISCALDANTE <i>PRE-HEATED FUEL FILTER</i>	KIT COLLEGAMENTO MONOTUBO CON FILTRO <i>SINGLE PIPE EXTERNAL FUEL TANK CONNECTION KIT WITH DEAERATOR</i>	FILTRO SEPARATORE ACQUA <i>ANTI-WATER FILTER</i>
		
Cod. 02AC548 €175,50	Cod. 02AC800 €215,50	Cod. 02AC801 €106,30



<p>FILTRO GAS GAS FILTER (P.in MAX 2 bar)</p>	<p>FILTRO REGOLATORE GAS GAS FILTER REGULATOR (P.in MAX 2 bar)</p>	<p>TUBO GAS MEDIA PRESSIONE (l = 3 m) + VALVOLA CHIUSURA + RACCORDI COLLEGAMENTO MEDIUM PRESSURE GAS HOSE (l = 3 m) + GAS VALVE + CONNECTIONS (P. MAX 10 bar)</p>
		
<p>Mod. FARM 85/110/145 (DN 25 - 1") Cod. 03AC603 €53,40</p>	<p>Mod. FARM 85/110/145 GAS METANO - NATURAL GAS (DN 25 3/4" or 1") (P.out set. 20mbar) Cod. 03AC617 €158,60</p>	<p>Mod. FARM 85/110/145 Tubo/Hose gas 1" Cod. 03AC615 €423,70</p>
<p>Mod. FARM 185/235 (DN 32 - 1 1/4") Cod. 03AC604 €103,70</p>	<p>Mod. FARM 85/110/145 GPL - LPG (DN 25 3/4" or 1") (P.out set. 30mbar) Cod. 03AC618 €158,60</p> <p>Mod. FARM 185/235 (DN 32 - 1 1/4") (P.out non settato - to be set) Cod. 03AC602 €364,30</p>	<p>Mod. FARM 185/235 Tubo/Hose gas 1 1/4" Cod. 03AC616 €583,50</p>
<p>TUBO GAS BASSA PRESSIONE (l = 2 m) + VALVOLA CHIUSURA + RACCORDI COLLEGAMENTO LOW PRESSURE GAS HOSE (l = 2 m) + GAS VALVE + CONNECTIONS (P.in MAX 0,5 bar)</p>	<p>CONTROLLO REMOTO PER SINGOLA MACCHINA (Distanza massima 3m) SINGLE UNIT REMOTE CONTROL (MAX DISTANCE 3m)</p>	<p>KIT TEMPORIZZATORE PER ACCENSIONE MACCHINE CON TEMPI DIFFERENTI E SEQUENZIALI DELAYED AND SEQUENTIAL STARTING RELAY</p>
		
<p>Mod. FARM 85/110/145 Tubo/Hose gas 1" Cod. 03AC612 €256,70</p>	<p>Cod. 02AC802 €131,90</p>	<p>Cod. 02AC803 €167,10</p>
<p>CONVERSA CHIMNEY PASS-PLATE</p>	<p>CURVA A 90° SCARICO FUMI IN INOX STAINLESS STEEL EXHAUST ELBOW</p>	<p>TUBO SCARICO FUMI INOX (L = 1 m) STAINLESS STEEL EXHAUST PIPE (L = 1 m)</p>
		
<p>Mod. FARM 85/110 (Ø 150 mm) Cod. 02AC432 €31,90</p>	<p>Mod. FARM 85/110 (Ø 150 mm) Cod. 02AC288 €57,20</p>	<p>Mod. FARM 85/110 (Ø 150 mm) Cod. 02AC285 €69,10</p>
<p>Mod. FARM 145/185/235 (Ø 200 mm) Cod. 02AC412 €32,40</p>	<p>Mod. FARM 145/185/235 (Ø 200 mm) Cod. 02AC290 €64,30</p>	<p>Mod. FARM 145/185/235 (Ø 200 mm) Cod. 02AC287 €83,60</p>
<p>TERMINALE PER CAMINO IN INOX STAINLESS STEEL CHIMNEY POT</p>	<p>RACCORDO ASPIRAZIONE 1 VIA AIR INLET ADAPTER</p>	<p>GUAINA RINFORZATA PER RIPRESA ARIA REINFORCED FLEXIBLE AIR INLET DUCT</p>
		
<p>Mod. FARM 85/110 (Ø 150 mm) Cod. 02AC657 €54,60</p>	<p>Mod. FARM 85 (Ø 505 mm) Cod. 02AC724 €87,90</p> <p>Mod. FARM 110 (Ø 565 mm) Cod. 02AC734 €95,60</p>	<p>Mod. FARM 85 (Ø 510 mm, l=6m) Cod. 02AC795 €447,90</p> <p>Mod. FARM 110 (Ø 570 mm, l=6m) Cod. 02AC796 €550,70</p>
<p>Mod. FARM 145/185/235 (Ø 200 mm) Cod. 02AC658 €59,80</p>	<p>Mod. FARM 145-185 (Ø 625 mm) Cod. 02AC744 €101,90</p> <p>Mod. FARM 235 (Ø 715 mm) Cod. 02AC764 €114,90</p>	<p>Mod. FARM 145-185 (Ø 650 mm, l=6m) Cod. 02AC797 €751,80</p> <p>Mod. FARM 235 (Ø 720 mm, l=6m) Cod. 02AC798 €1.157,20</p>

## FARM - GENERATORI D'ARIA CALDA PENSILI A GRANDE PORTATA A COMBUSTIONE INDIRETTA

FASCETTA FISSAGGIO GUAINA MANDATA E RIPRESA ARIA CLIP FOR FLEXIBLE AIR INLET/OUTLET DUCT	PROLUNGA RIDUZIONE TEMPERATURA PER GUAINA PREFORATA IN PVC PREFORATED PVC FLEXIBLE AIR DUCT EXTENSION	KIT FISSAGGIO GUAINA PREFORATA IN PVC PREFORATED PVC FLEXIBLE AIR DUCT HANGING KIT
		
<b>Mod. Tutti/All (Ø 400-750 mm)</b> <b>Cod. 02AC663</b> <span style="float: right;"><b>€11,70</b></span>	<b>Mod. FARM 85 (Ø 455 mm l=1 m)</b> <b>Cod. 02AC808</b> <span style="float: right;"><b>€121,20</b></span>	<b>Mod. Tutti - All (cavo/cable 45m + ganci/hooks)</b> <b>Cod. 02AC789</b> <span style="float: right;"><b>€112,50</b></span>
	<b>Mod. FARM 110 (Ø 505 mm l=1 m)</b> <b>Cod. 02AC809</b> <span style="float: right;"><b>€132,80</b></span>	
	<b>Mod. FARM 145 (Ø 605 mm l=1 m)</b> <b>Cod. 02AC810</b> <span style="float: right;"><b>€140,30</b></span>	<b>Mod. Tutti - All (cavo/cable 70m + ganci/hooks)</b> <b>Cod. 02AC790</b> <span style="float: right;"><b>€170,70</b></span>
	<b>Mod. FARM 185 (Ø 655 mm l=1 m)</b> <b>Cod. 02AC811</b> <span style="float: right;"><b>€159,40</b></span>	<b>Mod. Tutti - All (cavo/cable 120m + ganci/hooks)</b> <b>Cod. 02AC791</b> <span style="float: right;"><b>€276,00</b></span>
	<b>Mod. FARM 235 (Ø 705 mm l=1 m)</b> <b>Cod. 02AC812</b> <span style="float: right;"><b>€180,90</b></span>	

## GUAINE PREFORATE / PREFORATED DUCT

BM2 raccomanda l'utilizzo solo ed esclusivamente delle guaine preforate elencate in tabella (pag.101) le quali sono state studiate e definite per ciascun modello FARM al fine di ottenere sempre ed in qualunque situazione l'ottimale bilanciamento fra lunghezza della guaina stessa, la diffusione dell'aria calda ed un corretto funzionamento dei termostati di sicurezza. Inoltre le guaine sono state dotate di appositi occhielli metallici per una facile e sicura sospensione ed estensione/riduzione.

*In order to always obtain under all circumstances the optimal balance between the duct length, warm air diffusion and the correct functioning of safety thermostats, BM2 recommends to exclusively use only the perforated ducts listed in the the table (page 101) which have been designed and defined for each FARM model. Furthermore these ducts are supplied with special metal rings for safe and easy hanging, extension or reduction.*

GUAINE PREFORATE / PREFORATED DUCT

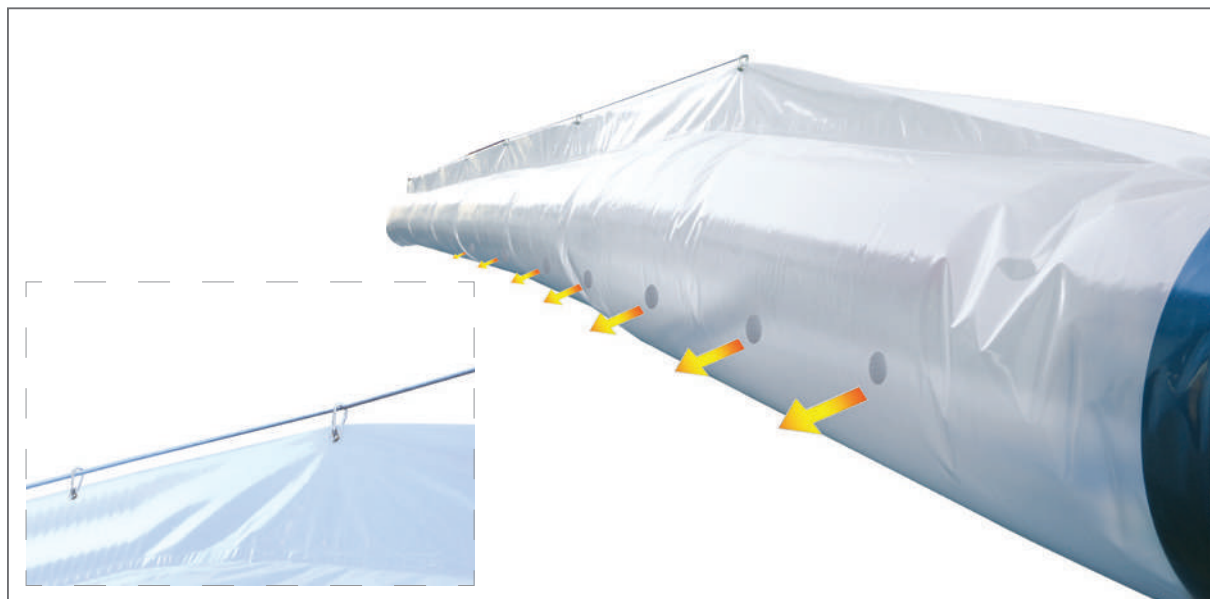

MODELLO MODEL	CODICE CODE	LUNGHEZZA GUAINA PREFORATA (m) LENGHT PREFORATED AIR DUCT (m)	Ø GUAINA PREFORATA (mm) Ø PREFORATED AIR DUCT (mm)	L.min RIDUCIBILE (m) REDUCTABLE L.min (m)	N° FORI (Ø 50 mm) N° HOLES (Ø 50 mm)	PREZZO PRICE
FARM 85	02AC766	25m (1 via/ 1 way)	500	10	200	€650,10
	02AC767	50m (1 via/ 1 way)	500	20	200	€1.300,10
	02AC768	100m (1 via/ 1 way)	500	40	200	€2.600,30
	02AC769	25m (2 vie/ 2 ways)	400	10	100	€640,30
	02AC770	50m (2 vie/ 2 ways)	400	20	100	€1.279,50
FARM 110	02AC771	25m (1 via/ 1 way)	500	10	270	€650,10
	02AC772	50m (1 via/ 1 way)	500	20	270	€1.300,10
	02AC773	100m (1 via/ 1 way)	500	40	270	€2.600,30
	02AC774	25m (2 vie/ 2 ways)	400	10	140	€640,30
	02AC775	50m (2 vie/ 2 ways)	400	20	140	€1.279,50
FARM 145	02AC776	25m (1 via/ 1 way)	600	15	200	€680,30
	02AC777	50m (1 via/ 1 way)	600	20	200	€1.360,70
	02AC778	100m (1 via/ 1 way)	600	40	200	€2.722,50
	02AC779	25m (2 vie/ 2 ways)	500	10	100	€650,10
	02AC780	50m (2 vie/ 2 ways)	500	20	100	€1.300,10
FARM 185	02AC781	25m (1 via/ 1 way)	700	15	200	€711,70
	02AC782	50m (1 via/ 1 way)	700	30	200	€1.423,60
	02AC783	100m (1 via/ 1 way)	700	60	200	€2.843,50
	02AC779	25m (2 vie/ 2 ways)	500	10	100	€650,10
	02AC780	50m (2 vie/ 2 ways)	500	30	100	€1.300,10
FARM 235	02AC784	25m (1 via/ 1 way)	700	15	250	€711,70
	02AC785	50m (1 via/ 1 way)	700	30	250	€1.423,60
	02AC786	100m (1 via/ 1 way)	700	60	250	€2.843,50
	02AC787	25m (2 vie/ 2 ways)	600	10	150	€680,30
	02AC788	50m (2 vie/ 2 ways)	600	30	150	€1.360,70

# FARM - GENERATORI D'ARIA CALDA PENSILI A GRANDE PORTATA A COMBUSTIONE INDIRETTA

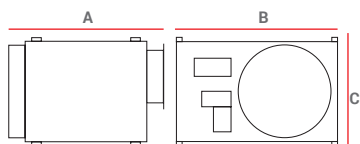

1/3

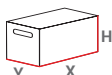

2/3

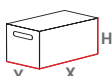

3/3

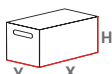

PESI E DIMENSIONI MACCHINA* WEIGHTS AND DIMENSIONS MACHINE					IMBALLO PACKAGING			
MOD	A	B	C	Netto/Net	X	Y	H	Lordo/Gross
	[mm]	[mm]	[mm]	[kg]	[mm]	[mm]	[mm]	[kg]
FARM 85	980	910	738	99	-	-	-	-
1/3	-	-	-	-	1.020	920	740	104
2/3	-	-	-	-	500	500	320	17
3/3	-	-	-	-	360	325	190	4,5
FARM 110	1.110	950	768	122	-	-	-	-
1/3	-	-	-	-	1.150	950	768	127
2/3	-	-	-	-	560	560	320	20
3/3	-	-	-	-	360	325	190	4,5
FARM 145	1.220	1.080	838	158	-	-	-	-
1/3	-	-	-	-	1.238	1.085	838	163
2/3	-	-	-	-	620	620	320	22
3/3	-	-	-	-	360	325	190	4,5
FARM 185	1.324	1.140	858	163	-	-	-	-
1/3	-	-	-	-	1.335	1.150	860	168
2/3	-	-	-	-	620	620	320	22
3/3	-	-	-	-	360	325	190	4,5
FARM 235	1.514	1.310	938	233	-	-	-	-
1/3	-	-	-	-	1.550	1.320	940	238
2/3	-	-	-	-	700	700	350	25
3/3	-	-	-	-	360	325	190	4,5

\* Macchina completa con bruciatore, ventilatore ed uscita 1 via frontale  
Complete machine with burner, fan and 1 way frontal adapter

## A RICHIESTA MACCHINA IMBALLATA (SCATOLA, PEDANA) ON DEMAND PACKAGING FOR FARM (CARTON BOX, PALLET)



MODELLO MODEL	CODICE CODE	DIMENSIONI IMBALLO PACKAGING DIMENSIONS	PESO LORDO TOTALE (kg) TOTAL GROSS WEIGHT (kg)	PREZZO NETTO IMBALLO* NET PRICE PACKAGING*
FARM 85 (MONOFASE-SINGLE PHASE)	99AA120	1490 x 960 x h= 910	123	€130,00
FARM 110 (MONOFASE-SINGLE PHASE)	99AA130	1660 x 1010 x h= 930	142	€130,00
FARM 145 (MONOFASE-SINGLE PHASE)	99AA140	1795 x 1120 x h= 1010	187	€130,00
FARM 185 (MONOFASE-SINGLE PHASE)	99AA150	1930 x 1210 x h= 1030	204	€169,00
FARM 235 (MONOFASE-SINGLE PHASE)	99AA160	2130 x 1370 x h= 1110	258	€169,00
FARM 145 (TRIFASE-THREE PHASE)	99AA140	1795 x 1120 x h= 1010	187	€130,00
FARM 185 (TRIFASE-THREE PHASE)	99AA150	1930 x 1210 x h= 1030	204	€169,00
FARM 235 (TRIFASE-THREE PHASE)	99AA160	2130 x 1370 x h= 1110	258	€169,00

\* Da aggiungere al prezzo della macchina - To be added to the price of the machine

## FARM - INDIRECT COMBUSTION HEAVY DUTY SUSPENDED SPACE HEATERS

MODELLO MODEL		MONOFASE / SINGLE PHASE					TRIFASE / THREE PHASE		
		FARM 85M * (OIL-GAS)	FARM 110M * (OIL-GAS)	FARM 145M * (OIL-GAS)	FARM 185M * (OIL-GAS)	FARM 235M * (OIL-GAS)	FARM 145T * (OIL-GAS)	FARM 185T * (OIL-GAS)	FARM 235T * (OIL-GAS)
CODICE CODE		02FA121	02FA131	02FA141	02FA151	02FA161	02FA142	02FA152	02FA162
POTENZA TERMICA NOMINALE RATED HEAT POWER	Hs [kW] Hs [kcal/h - BTU/h]	85,62 73.630 294.518	110,46 94.999 379.996	144,72 124.455 497.821	185,54 159.563 638.254	235,72 202.715 810.861	144,72 124.455 497.821	185,54 159.563 638.254	235,72 202.715 810.861
POTENZA TERMICA RESA OUTPUT HEAT POWER	Hs [kW] Hs [kcal/h - BTU/h]	79,37 68.255 273.019	102,51 88.159 352.636	134,87 115.992 463.969	171,07 147.117 588.470	216,86 186.498 745.992	134,87 115.992 463.969	171,07 147.117 588.470	216,86 186.498 745.992
RENDIMENTO EFFICIENCY	[ % ]	92,70	92,80	93,20	92,20	92,00	93,20	92,20	92,00
PORTATA D'ARIA AIR FLOW	[ m <sup>3</sup> /h ]	7.000	8.500	11.000	12.000	16.200	11.000	12.000	16.200
PRESS. STATICA DISP. AVAILABLE STATIC PRESS	[ Pa- mm H <sub>2</sub> O ]	200-20	200-20	200-20	200-20	200-20	200-20	200-20	200-20
SALTO TERMICO TEMPERATURE RISE	a 20°C [ °C ]	48	52	52	61	58	52	61	58
CAMPO DI LAVORO EFFETTIVO EFFECTIVE HEAT RANGE	[ m ]	45	43	43	51	55	43	51	55
CONSUMO GASOLIO OIL CONSUMPTION	[ kg/h ]	6,77	8,74	11,45	14,68	18,65	11,45	14,68	18,65
CONSUMO METANO NATURAL GAS CONSUMPTION G20	[ m <sup>3</sup> /h ]	7,935	10,433	13,664	17,383	22,095	13,664	17,383	22,095
PRESSIONE ALIM. INLET PRESSURE G20	[ mbar ]	20	20	20	20	20	20	20	20
CONSUMO GPL LPG CONSUMPTION G31	[ m <sup>3</sup> /h - kg/h ]	3,127 - 6,10	4,191 - 8,07	5,436 - 10,53	6,976 - 13,59	8,819 - 17,17	5,436 - 10,53	6,976 - 13,59	8,819 - 17,17
PRESSIONE ALIM. INLET PRESSURE G31	[ mbar ]	30/37	30/37	30/37	30/37	30/37	30/37	30/37	30/37
ALIMENTAZIONE ELETTRICA ELECTRICAL POWER	[ V - ph - Hz ]	230-1-50	230-1-50	230-1-50	230-1-50	230-1-50	400-3-50 (230-3-50)◆	400-3-50 (230-3-50)◆	400-3-50 (230-3-50)◆
POTENZA ELETTRICA POWER CONSUMPTION	[ W ]	670	1.190	1.570	1.550	2.550	1.500	1.550	2.500
Ø CAMINO Ø FLUE	[ mm ]	150	150	200	200	200	200	200	200
Ø GUAINA USCITA ARIA PREFORATA / L. MAX. Ø OUTLET PREFORATED DUCT/ L. MAX **	[ mm/m ] 1 VIA	500/100	500/100	600/100	700/100	700/100	600/100	700/100	700/100
	[ mm/m ] 2 VIE	400/50	400/50	500/50	500/50	600/50	500/50	500/50	600/50
Ø GUAINA SNORKEL / L. MAX. Ø OUTLET SNORKEL / L. MAX	[ mm/m ]	100/5	100/5	100/5	100/5	150/5	100/6	100/6	150/6
Ø GUAINA RIPRESA ARIA / L. MAX. Ø INLET HOSE / L. MAX	[ mm/m ]	510/6	570/6	650/6	650/6	720/6	650/6	650/6	720/6
PREZZO - PRICE	EURO	<b>3.088,00</b>	<b>3.368,00</b>	<b>3.941,00</b>	<b>4.717,00</b>	<b>5.402,00</b>	<b>3.941,00</b>	<b>4.717,00</b>	<b>5.548,00</b>

\* Macchina senza bruciatore ed uscita aria - Machine without burner and air adapter

\*\* Vedi pag.101 - See page 101

◆ Disponibile su richiesta - Available on demand

FARM - GENERATORI D'ARIA CALDA PENSILI A GRANDE PORTATA A COMBUSTIONE  
INDIRETTA  
INDIRECT COMBUSTION HEAVY DUTY SUSPENDED SPACE HEATERS

IMBALLAGGIO/PACKAGING

FARM 85		
	FARM smontati orizzontali * <i>FARM horizontal disassembled *</i>	FARM montati orizzontali con imballo e pedana * <i>FARM horizontal, assembled with carton box and pallet *</i>
CONTAINER 20'	27	16
CONTAINER 40'	60	32
CONTAINER 40' HC	60	48
TIR	66	69

FARM 110		
	FARM smontati orizzontali * <i>FARM horizontal disassembled *</i>	FARM montati orizzontali con imballo e pedana * <i>FARM horizontal, assembled with carton box and pallet *</i>
CONTAINER 20'	24	12
CONTAINER 40'	51	28
CONTAINER 40' HC	51	42
TIR	60	48

FARM 145		
	FARM smontati orizzontali * <i>FARM horizontal disassembled *</i>	FARM montati orizzontali con imballo e pedana * <i>FARM horizontal, assembled with carton box and pallet *</i>
CONTAINER 20'	14	12
CONTAINER 40'	30	28
CONTAINER 40' HC	42	28
TIR	38	28

FARM 185		
	FARM smontati orizzontali * <i>FARM horizontal disassembled *</i>	FARM montati orizzontali con imballo e pedana * <i>FARM horizontal, assembled with carton box and pallet *</i>
CONTAINER 20'	10	8
CONTAINER 40'	20	20
CONTAINER 40' HC	30	20
TIR	22	22

FARM 235		
	FARM smontati orizzontali * <i>FARM horizontal disassembled *</i>	FARM montati orizzontali con imballo e pedana * <i>FARM horizontal, assembled with carton box and pallet *</i>
CONTAINER 20'	8	8
CONTAINER 40'	18	16
CONTAINER 40' HC	18	16
TIR	20	20

\* Quantità massima da verificare a seconda degli accessori selezionati - *Maximum values to be verified depending on the chosen accessories*



AGRICOLTURA E ALLEVAMENTO  
AGRICULTURE AND BREEDING

# EK P

GENERATORI MOBILI D'ARIA CALDA A CORRENTE ELETTRICA  
ELECTRICAL MOBILE SPACE HEATERS

## EK P - GENERATORI MOBILI D'ARIA CALDA A CORRENTE ELETTRICA ELECTRICAL MOBILE SPACE HEATERS

- Struttura interna ed esterna in acciaio inox
- Possibilità di installazione orientabile a parete o a soffitto tramite la maniglia in dotazione
- Resistenze elettriche corazzate AISI 321 ad alto scambio termico
- Termostato automatico di FAN per ventilare solo aria calda, con il pre-riscaldamento delle resistenze e post-ventilazione di raffreddamento
- Termostato OVERHEATING di surriscaldamento a riarmo manuale
- Commutatore quattro posizioni (15 kW, 10 kW, 0, Ventilazione)
- Quadro elettrico protezione IP55
- Possibilità di interfaccia con termostato, umidostato o timer
- Motore IP55
- Griglia anteriore in acciaio inox
- Controllo remoto, cavo l = 3 m
- High grade stainless steel body
- Delivered with a frame allowing adjustable installation to a wall or to a ceiling
- High strength electrical resistances AISI 321 with big thermal exchange surface
- Fan thermostat to avoid cold drafts. Fan starts once resistances are warm and stops when resistances are cold
- Safety OVERHEATING manual reset thermostat
- Four positions switch (15 kW, 10kW, 0, FAN)
- IP55 electric board grade protection
- Connectable to external climate computer
- IP55 protection grade motor
- Stainless steel front protection grid
- Remote control, cable l = 3 m



### ACCESSORI A RICHIESTA / ACCESSORIES ON DEMAND

TERMOSTATO AMBIENTE +5/+30°C CON CAVO L=10 m E SPINA 90° ROOM THERMOSTAT +5/+30°C CABLE 10 m, PLUG 90°	TERMOSTATO AGRICOLTURA/CANTIERE -5/+50°C CON CAVO L=10 m E SPINA 90° HEAVY DUTY THERMOSTAT -5/+50°C CABLE 10 m, PLUG 90°	TERMOSTATO ELETTRONICO DI PRECISIONE IP55 CON DISPLAY -10/+70°C SENZA CAVO E SPINA ELECTRONIC THERMOSTAT IP55 WITH DISPLAY -10/+70°C WITHOUT POWER CORDAND PLUG	SPINA 4-5 POLI 4-5 PIN PLUG
			
Cod. 02AC581      €49,30	Cod. 02AC582      €98,80	Cod. 02AC294      €186,40	Mod. 3P+↓ Cod. 06AC103 32A      €17,40 Mod. 3P+↓+N Cod. 06AC105 32A      €20,10

PESI E DIMENSIONI MACCHINA WEIGHTS AND DIMENSIONS MACHINE					IMBALLO PACKAGING			
MOD	A	B	C	Netto/Net	X	Y	H	Lordo/Gross
	[mm]	[mm]	[mm]	[kg]	[mm]	[mm]	[mm]	[kg]
EK 15 P	768	450	445	20	632	432	350	21

		EK 15 P
codice - code		06EK503
potenza term. nominale max max rated heat power	Hs [kW] Hs [ kcal/h - BTU/h ]	15 12.900 - 51.185
potenza term. nominale min. min rated heat power	Hs [kW] Hs [ kcal/h - BTU/h ]	10 8.600 - 34.120
rendimento - heat efficiency	[ % ]	100
portata d'aria - air flow	[ m³/h ]	2.000
salto termico - temperature rise	a 20°C [ °C ]	54,3 - 35
corrente massima - current max	[ A ]	21 - 13,8
alimentazione elettrica - electrical power	[ V - ph - Hz ]	400 - 3 - 50
quantità per pallet - pallet quantities	[ pz - pcs ]	24
<b>PREZZO - PRICE</b>	<b>EURO</b>	<b>927,00</b>





# FJ

VENTILATORI ASSIALI  
AXIAL FANS

## FJ - VENTILATORI ASSIALI / AXIAL FANS

- Struttura interna ed esterna in acciaio INOX
  - Motore IP 44 con protezione termica
  - Ventola a tre pale
  - Ganci di sospensione
  - Doppia rete di protezione (lato motore e lato ventola)
  - Raddrizzatori flusso aria
- *Stainless steel housing AISI*
  - *IP 44 protection grade motor with thermal circuit breaker*
  - *Three blades Propeller*
  - *Integrated suspending hooks*
  - *Double safety guard (motor side and blade side)*
  - *Air flow rectifiers*

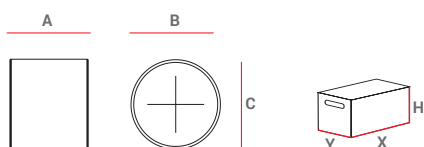
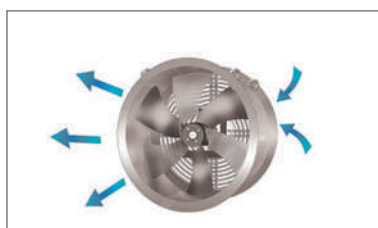

PESI E DIMENSIONI MACCHINA WEIGHTS AND DIMENSIONS MACHINE				IMBALLO PACKAGING				
MOD	A	B	C	Netto/Net	X	Y	H	Lordo/Gross
	[mm]	[mm]	[mm]	[kg]	[mm]	[mm]	[mm]	[kg]
FJ 18 M/T	430	489	486	14	500	500	460	15,5
FJ 22 M/T	439	570	567	18	590	590	460	19
FJ 25 T	480	652	650	20,5	670	670	530	22

		FJ 18 M	FJ 18 T	FJ 22 M	FJ 22 T	FJ 25 T
codice - code		02FJ101	02FJ102	02FJ103	02FJ104	02FJ105
potenza motore - motor power	[W]	135/164	190/210	270/313	250/295	330/374
giri motori - motor speed	[g/min]	940	940	940	940	940
portata d'aria - air flow	[m³/h]	4.750	4.750	8.000	8.000	12.050
Ø ventola - propeller Ø	[mm]	450	450	550	550	630
pale ventola - propeller blades	[n°]	3	3	3	3	3
corrente massima - current max	[A]	0,65/0,79	0,50/0,60	1,15/1,50	0,60/0,68	0,69/0,74
materiale - material		alluminio	alluminio	alluminio	alluminio	plastica
alimentazione elettrica - electrical power	[V - ph - Hz]	230 - 1 - 50/60	400 - 3 - 50/60	230 - 1 - 50/60	400 - 3 - 50/60	400 - 3 - 50/60
quantità per pallet - pallet quantities	[pz - pcs]	16	16	14	14	4
<b>PREZZO - PRICE</b>	<b>EURO</b>	<b>462,00</b>	<b>462,00</b>	<b>547,00</b>	<b>547,00</b>	<b>661,00</b>

# INDUSTRIA *INDUSTRY*



# BM2

## INDUSTRIA - INDUSTRY

Fanno parte di questa famiglia i generatori di aria calda che non possono essere considerati totalmente mobili e d'emergenza in quanto tutti richiedono limitate opere accessorie per la loro installazione. Vengono impiegati normalmente nel riscaldamento tradizionale (magazzini, capannoni, laboratori, opifici, ecc...) e, grazie all'economicità dell'investimento, sono una proposta alternativa agli impianti di riscaldamento convenzionali. Si tratta di prodotti con struttura che si sviluppa in verticale e sono tutti a combustione indiretta: impiegano uno scambiatore di calore che permette l'evacuazione dei fumi attraverso un camino collegabile con l'esterno; possono quindi essere collocati all'interno di locali chiusi, per contro hanno un rendimento intorno al 90% dovendosi calcolare, in riduzione la quantità di calore evacuata attraverso il camino. Fanno parte di questa famiglia:

*This family includes space heaters that cannot be considered completely mobile and for emergency use because they all require minor installation work.*

*They are normally used for traditional heating (warehouses, industrial sheds, laboratories, factories, etc.) and, thanks to the low cost of the investment, they are an excellent alternative to conventional heating plants. These heaters have a vertical structure and are all with indirect combustion, using a heat exchanger that expels fumes through a chimney connected to the outside. Therefore, they can be operated in closed rooms. On the other hand, they have efficiency of about 90% due to the heat lost through the chimney.*

This family includes:



**VERTIGO:** alimentato a gasolio, con bruciatore, serbatoio e termostato integrato. Grazie alle contenute dimensioni, trova impiego in ambienti di superficie contenuta come ristoranti, chiese, sale convegni oppure garage, officine, laboratori, ecc...Qualora si rendesse necessario, sono facilmente spostabili.

**VERTIGO:** diesel-fuelled, with integrated burner, tank, and thermostat. This compact heater can be used in small spaces such as restaurants, churches, conference rooms or garages, machine shops, laboratories, etc., and can be moved easily whenever necessary.



**CONFORT:** macchine progettate per essere installate prevalentemente in ambienti commerciali e industriali, con un design gradevole e robusto. Sono dotati di un quadro controllo facile ed intuitivo, con termostato ambiente elettronico, spie di segnalazione e ventilatore centrifugo che conferisce alla macchina grandi portate d'aria con alta prevalenza unita a silenziosità.

**CONFORT:** machines designed to be installed mainly in industrial environments, with a pleasant and robust design. They are equipped with an easy and intuitive control panel, with electronic room thermostat, indicator lights and centrifugal fan that gives the machine high air flow rates with high head and low noise.



**SP:** alimentabili a gasolio oppure GPL o metano con bruciatore separato, sono tutti dotati di ventilatore centrifugo e vengono impiegati principalmente laddove è richiesta una grande movimentazione d'aria e/o sono presenti ampie superfici da scaldare. Mediante l'impiego di appositi accessori, sono facilmente configurabili per le diverse esigenze di applicazione siano esse a mandata libera o canalizzata.

**SP:** powered by diesel, LPG or methane, with separate burner. These models are all fit with a centrifugal fan and are used primarily where large volumes of air must be moved and/or there are large areas to be heated. Thanks to various accessories, they are easily configured for all types of applications, both channelled and un-channelled.



# VERTIGO

GENERATORI D'ARIA CALDA PLUG & PLAY A COMBUSTIONE INDIRETTA  
*INDIRECT COMBUSTION PLUG AND PLAY CABINET SPACE HEATERS*

- Generatore d'aria calda molto silenzioso adatto per locali chiusi (ristoranti, chiese, sale convegni etc)
  - Bruciatore integrato a gasolio
  - Controllo elettronico di fiamma
  - Termostato ambiente integrato (+5°/+30° C) e collegabile con termostato ambiente remoto
  - Ventilatore radiale a pale rovesce
  - Cavo alimentazione elettrica 1,5 m con spina
  - Filtro gasolio
  - Camera di combustione aerodinamica in acciaio inox
  - Scambiatore di calore ad alto rendimento
  - Serbatoio gasolio l=35 con indicatore di livello della riserva combustibile
  - Tubo scarico fumi inox passaparete l = 0,6 m
  - Pre-riscaldamento e post-ventilazione di raffreddamento della camera di combustione
  - Commutatore inverno-estate per utilizzo come ventilatore
  - Possibilità di ricircolo aria con generatore posizionato all'esterno
  - Griglie di aspirazione e mandata
  - Possibilità di movimentazione su ruote a scomparsa
  - Facile manutenzione
- *Low-noise forced air space heaters suitable for indoor facilities*
  - *Integrated burner oil*
  - *Electronic flame-control*
  - *Room thermostat integrated (+5°/+30° C) and can be connected to remote ambient thermostat*
  - *Reverse blades radial fan*
  - *Power cord (1,5 m) with plug*
  - *Oil filter*
  - *Stainless steel combustion chamber with aerodynamic shape*
  - *High efficiency heat exchanger*
  - *35 liters fuel tank with fuel reserve level gauge*
  - *Stainless steel exhaust passplate pipe l = 0,6 m*
  - *Pre-heating and automatic post ventilation of the combustion chamber*
  - *Summer-winter switch for use as a fan*
  - *Air recycling option when heater is placed outside the facilities (bar, restaurant, etc.)*
  - *Air inlet/outlet grills*
  - *Can be moved on retractable wheels*
  - *Easy maintenance*



ACCESSORI A RICHIESTA / ACCESSORIES ON DEMAND

RACCORDO MANDATA ARIA AIR OUTLET ADAPTER		RACCORDO ASPIRAZIONE AIR INLET ADAPTER			
					
Cod. 02AC672	€202,20	Cod. 02AC671	€187,70		
<b>TERMOSTATO AMBIENTE +5/+30°C</b> CON CAVO L=10 m E SPINA 90° ROOM THERMOSTAT +5/+30°C CABLE 10 m, PLUG 90°		<b>TERMOSTATO ELETTRONICO DI PRECISIONE IP55 CON DISPLAY -10/+70°C SENZA CAVO E SPINA</b> ELECTRONIC THERMOSTAT IP55 WITH DISPLAY -10/+70°C WITHOUT POWER CORD AND PLUG		<b>TUBO SCARICO FUMI INOX L = 1 m</b> STAINLESS STEEL EXHAUST PIPE L = 1 m	
					
Cod. 02AC581	€49,30	Cod. 02AC294	€186,40	Mod. Ø 120 mm Cod. 02AC420	€54,60
<b>CURVA A 90° SCARICO FUMI IN INOX</b> STAINLESS STEEL EXHAUST ELBOW		<b>TERMINALE PER CAMINO IN INOX</b> STAINLESS STEEL CHIMNEY POT			
					
Mod. Ø 120 mm Cod. 02AC421	€52,10	Mod. Ø 120 mm Cod. 02AC422	€48,10		

# VERTIGO - GENERATORI D'ARIA CALDA PLUG & PLAY A COMBUSTIONE INDIRECTA INDIRECT COMBUSTION PLUG AND PLAY CABINET SPACE HEATERS

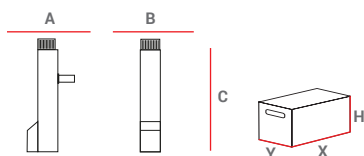

PESI E DIMENSIONI MACCHINA WEIGHTS AND DIMENSIONS MACHINE				IMBALLO PACKAGING				
MOD	A	B	C	Netto/Net	X	Y	H	Lordo/Gross
	[mm]	[mm]	[mm]	[kg]	[mm]	[mm]	[mm]	[kg]
VERTIGO 18	553	370	1996	67	2050	420	780	82

		VERTIGO 18
codice - code		04VE106
potenza term. nominale - rated heat power	Hs [kW] Hs [ kcal/h - BTU/h ]	18,2 15.652 - 62.295
potenza term. resa - output heat power	Hs [kW] Hs [ kcal/h - BTU/h ]	16,9 14.556 - 57.934
rendimento - heat efficiency	[ % ]	93
portata d'aria - air flow	[m <sup>3</sup> /h]	1750
salto termico - temperature rise	a 20°C [ °C ]	60
consumo - fuel consumption	[kg/h]	1,44
capacità serbatoio - tank capacity	[ l ]	35
potenza elettrica - power consumption 230V	[ W ]	400
alimentazione elettrica - electrical power	[ V - ph - Hz ]	230 - 1 - 50
∅ camino - ∅ flue	[ mm ]	120
quantità per pallet - pallet quantities	[ pz - pcs ]	1
<b>PREZZO - PRICE</b>	<b>EURO</b>	<b>1.962,00</b>







# CONFORT

GENERATORI D'ARIA CALDA FISSI INDUSTRIALI PLUG & PLAY A COMBUSTIONE INDIRETTA  
*INDIRECT COMBUSTION INDUSTRIAL PLUG AND PLAY CABINET SPACE HEATERS*

## CONFORT - GENERATORI D'ARIA CALDA FISSI INDUSTRIALI PLUG & PLAY A COMBUSTIONE INDIRECTA

- Bruciatore automatico a gasolio separato
  - Controllo elettronico di fiamma
  - Termostato ambiente elettronico incorporato (0°/+40° C)
  - Ventilatore centrifugo
  - Bitermostato FAN-LIMIT a riarmo automatico
  - Termostato di sicurezza a riarmo manuale
  - Cavo alimentazione elettrica con spina
  - Serbatoio gasolio integrato per autonomia > 16 ore
  - Indicatore livello riserva gasolio integrato
  - Struttura esterna in doppia lamiera d'acciaio per isolamento termo-acustico
  - Camera di combustione aerodinamica in acciaio inox ad alto rendimento
  - Pre-riscaldamento e post-ventilazione di raffreddamento della camera di combustione
- Automatic oil burner
  - Electronic flame control
  - Built-in electronic room thermostat (0°/+40° C)
  - Centrifugal fan
  - Automatic reset FAN-LIMIT bi-thermostat
  - Manual reset safety overheat thermostat
  - Power cord with plug
  - 16 hours runtime integrated fuel tank
  - Integrated fuel level indicator
  - Double skinned body for thermo-acoustic insulation and safe low surface temperature
  - High efficiency stainless steel combustion chamber with aerodynamic shape
  - Pre-heating and automatic post ventilation of the combustion chamber



ACCESSORI A RICHIESTA / ACCESSORIES ON DEMAND

TESTATA DIFFUSIONE ARIA ALETTE ORIENTABILI (PLENUM) AIR OUTLET WITH ADJUSTABLE LOUVRES (PLENUM)		TESTATA DIFFUSIONE ARIA GIREVOLE A 360° CON ALETTE ORIENTABILI AIR OUTLET HEAD WITH ADJUSTABLE LOUVRES, REVOLVING AT 360°		KIT PIEDI FEET KIT	
					
Mod. CONFORT 35 Cod. 04AC101	€199,90	Mod. CONFORT 35 Cod. 04AC104	€199,90	Mod. Tutti - All Cod. 04AC110	€95,70
Mod. CONFORT 70 Cod. 04AC102	€207,50	Mod. CONFORT 70 Cod. 04AC105	€207,50		
Mod. CONFORT 100 Cod. 04AC103	€233,90				
KIT RUOTE (PIVOTTANTI) WHEELS KIT (SWIVELLING)		RACCORDO ASPIRAZIONE AIR INLET ADAPTER		GUAINA RINFORZATA PER RIPRESA ARIA REINFORCED FLEXIBLE AIR INLET DUCT	
					
Mod. CONFORT 35 - 70 (Ø 100 mm) Cod. 04AC111	€161,00	Mod. CONFORT 35 (Ø 505 mm) Cod. 04AC112	€94,80	Mod. CONFORT 35 (Ø 510 mm, l=6m) Cod. 02AC795	€447,90
		Mod. CONFORT 70 (Ø 565 mm) Cod. 04AC113	€97,40	Mod. CONFORT 70 (Ø 570 mm, l=6m) Cod. 02AC796	€550,70
		Mod. CONFORT 100 (Ø 625 mm) Cod. 04AC114	€105,00	Mod. CONFORT 100 (Ø 650 mm, l=6m) Cod. 02AC797	€751,80
Mod. Tutti/All Fascetta fissaggio guaina- Clip for flexible duct (Ø 400-750 mm) Cod. 02AC663				€11,70	
KIT SERRANDA TAGLIAFUOCO INGRESSO ARIA (REI 120) AIR INLET FIRE SHUTTER KIT (REI 120)		ADATTATORE USCITA ARIA OUTLET ADAPTER			
					
Mod. CONFORT 35 (Ø 505 mm) Cod. 02AC908*	€889,80	Mod. CONFORT 35 Cod. 04AC107	€161,90	Mod. A CONFORT 35 (Ø 450 mm) Cod. 02AC821**	€182,20
				Mod. B CONFORT 35 (Ø 400 mm) Cod. 02AC822**	€203,10
				Mod. C CONFORT 35 Cod. 02AC828**	€767,50
Mod. CONFORT 70 (Ø 565 mm) Cod. 02AC909*	€900,70	Mod. CONFORT 70 Cod. 04AC108	€179,60	Mod. A CONFORT 70 (Ø 500 mm) Cod. 02AC831**	€195,80
				Mod. B CONFORT 70 (Ø 400 mm) Cod. 02AC832**	€224,70
				Mod. C CONFORT 70 Cod. 02AC838**	€806,30
Mod. CONFORT 100 (Ø 625 mm) Cod. 02AC910*	€1.041,10	Mod. CONFORT 100 Cod. 04AC109	€192,30	Mod. A CONFORT 100 (Ø 600 mm) Cod. 02AC871**	€216,30
				Mod. B CONFORT 100 (Ø 500 mm) Cod. 02AC872**	€249,90
				Mod. C CONFORT 100 Cod. 02AC878**	€851,00

\* Necessario abbinamento a "raccordo aspirazione aria" - Additionally it's necessary to buy "air inlet adapter"

\*\* Necessario abbinamento a "adattatore uscita aria" - Additionally it's necessary to buy "outlet adapter"

**CONFORT - GENERATORI D'ARIA CALDA FISSI INDUSTRIALI PLUG & PLAY A  
 COMBUSTIONE INDIRECTA  
 INDIRECT COMBUSTION INDUSTRIAL PLUG AND PLAY CABINET SPACE  
 HEATERS**

TUBO SCARICO FUMI INOX L = 1 m STAINLESS STEEL EXHAUST PIPE L = 1 m	CURVA A 90° SCARICO FUMI IN INOX STAINLESS STEEL EXHAUST ELBOW	TERMINALE PER CAMINO IN INOX STAINLESS STEEL CHIMNEY POT
		
Mod. Ø 150 mm Cod. 02AC285 <b>€69,10</b>	Mod. Ø 150 mm Cod. 02AC288 <b>€57,20</b>	Mod. Ø 150 mm Cod. 02AC657 <b>€54,60</b>

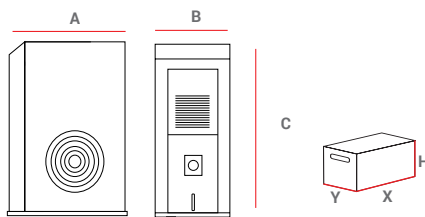

MOD	PESI E DIMENSIONI MACCHINA WEIGHTS AND DIMENSIONS MACHINE			IMBALLO PACKAGING				
	A [mm]	B [mm]	C [mm]	Netto/Net [kg]	X [mm]	Y [mm]	H [mm]	Lordo/Gross [kg]
CONFORT 35	1.010	530	1.360	141	1.055	580	1.510	161
CONFORT 70	1.045	600	1.530	184	1.120	650	1.680	204
CONFORT 100	1.400	640	1.650	259	1.465	690	1.800	279



		CONFORT 35	CONFORT 70	CONFORT 100
codice - code		04CB101	04CB102	04CB103
potenza term. nominale - rated heat power	Hs [kW] Hs [kcal/h - BTU/h]	35,89 30.869-123.477	70,15 60.325-241.302	100,10 86.086-344.344
potenza term. resa - output heat power	Hs [kW] Hs [kcal/h - BTU/h]	32,78 28.187-112.747	64,73 55.668-222.673	91,12 78.364-313.456
rendimento termico- heat efficiency	[ % ]	91,31	92,28	91,03
portata d'aria - air flow	[m³/h]	2.700	6.000	7.800
press. Statica disp. - available static press.	[Pa - mm H <sub>2</sub> O]	150-15	150-15	150-15
consumo - fuel consumption	[kg/h]	2,84	5,55	7,92
capacità serbatoio - tank capacity	[ l ]	80	110	110
autonomia - run time	[ h ]	25	17	12
potenza elettrica - power consumption 230V	[ W ]	690	1.360	1.800
alimentazione elettrica - electrical power	[ V - ph - Hz ]	230-1-50	230-1-50	230-1-50
salto termico - temperature rise	[ °C ]	40	49	41
Ø camino - Ø flue	[ mm ]	150	150	150
<b>PREZZO - PRICE</b>	<b>EURO</b>	<b>4.202,00</b>	<b>5.445,00</b>	<b>6.744,00</b>



		CONFORT 35	CONFORT 70	CONFORT 100
codice - code		04CB111	04CB112	04CB113
potenza term. nominale - rated heat power	Hs [kW] Hs [kcal/h - BTU/h]	27,55 23.695-94.782	59,53 51.195-204.780	79,88 68.695-274.780
potenza term. resa - output heat power	Hs [kW] Hs [kcal/h - BTU/h]	25,94 22.304-89.218	55,71 47.908-191.633	75,15 64.628-258.513
rendimento termico- heat efficiency	[ % ]	94,13	93,58	94,08
portata d'aria - air flow	[m³/h]	2.700	6.000	7.800
press. Statica disp. - available static press.	[Pa - mm H <sub>2</sub> O]	150-15	150-15	150-15
consumo - fuel consumption	[kg/h]	2,18	4,71	6,32
capacità serbatoio - tank capacity	[ l ]	80	110	110
autonomia - run time	[ h ]	31,5	20	15
potenza elettrica - power consumption 230V	[ W ]	690	1.360	1.800
alimentazione elettrica - electrical power	[ V - ph - Hz ]	230-1-50	230-1-50	230-1-50
salto termico - temperature rise	[ °C ]	31	37,5	31
Ø camino - Ø flue	[ mm ]	150	150	150
<b>PREZZO - PRICE</b>	<b>EURO</b>	<b>4.712,00</b>	<b>6.006,00</b>	<b>7.493,00</b>



SP

GENERATORI D'ARIA CALDA FISSI INDUSTRIALI A COMBUSTIONE INDIRECTA  
INDIRECT COMBUSTION INDUSTRIAL CABINET SPACE HEATERS

- Bruciatore dotato di presa snorkel per garantire aria di combustione pulita mediante collegamento con guaina di aspirazione aria all'esterno
  - Il nuovo scambiatore di calore abbinato ai nuovi ventilatori di maggiori prestazioni permettono di ottenere un rendimento termico del 92 ÷ 93%
  - Pre riscaldamento e Post ventilazione camera di combustione
  - Pannelli con pieghe di rinforzo a croce per garantire maggior rigidità e robustezza (SP 110-235)
  - Termostati: FAN per il controllo ventilatore; LIMIT per il controllo del bruciatore; OVERHEATING termostato di sicurezza in caso di surriscaldamento con riarmo manuale.
  - Struttura portante con pannelli rimovibili per il lavaggio interno
  - Utilizzo esclusivamente di viti e inserti metrici per il fissaggio, no viti autofilettanti
  - Ventilatore protezione (IP 55):
    - molto silenzioso ( rumore  $\leq 69$  db a 2 metri);
    - ad alta prevalenza e prestazioni che garantisce un elevata portata d'aria e pressione statica (500 Pa) per la diffusione omogenea ed a lunga distanza dell'aria calda mediante canalizzazioni o guaine;
    - ventilatore ancorato alla struttura portante mediante robusti longheroni e staffe di fissaggio (SP 110-235);
    - serranda regolabile di ripristino aria fresca (SP 110-235);
  - Quadro elettrico di comando (IP 65):
    - collegabile a termostato/umidostato/timer
    - incassato nella parte inferiore
- *Burner is supplied with snorkel outlet to ensure clean combustion air through connection with external air aspiration duct*
  - *The new heat exchanger combined with the new high-performance fans allow for heat output of 92 / 93%*
  - *Before heating and after cooling of combustion chamber*
  - *Panel with reinforcement cross pleats to ensure superior rigidity and strenght (SP 110-235)*
  - *Thermostat: FAN for fan control; LIMIT: for burner control; OVERHEATING: safety thermostat in case of overheating, with manual reset*
  - *Bearing structure with removable panels for internal washing*
  - *All installation inserts and screws are exclusively metric, not self-tapping*
  - *Ventilator (IP 55):*
    - *very low noise fan (noise level  $\leq 69$ db at 2 meters)*
    - *high output, high performance fan guarantees increased air flow and static pressure (500 Pa) for uniform and long distance diffusion of warm air through channels or ducts*
    - *fan anchorage on machine's bearing structure through sturdy rods (SP 110-235);*
    - *adjustable fresh air re-uptake shutter (SP 110-235);*
  - *Control rear electrical panel (IP 65):*
    - *can be connected to thermostat/humidistat/timer*
    - *Integrated in the bottom side*



ACCESSORI A RICHIESTA / ACCESSORIES ON DEMAND

TESTATA DIFFUSIONE ARIA ALETTE ORIENTABILI (PLENUM) AIR OUTLET WITH ADJUSTABLE LOUVRES (PLENUM)	TESTATA DIFFUSIONE ARIA GIREVOLE A 360° CON ALETTE ORIENTABILI AIR OUTLET HEAD WITH ADJUSTABLE LOUVRES, REVOLVING AT 360°	KIT PROTEZIONE BRUCIATORE BURNER PROTECTION KIT
		
Mod. SP 35 Cod. 04AC101 €199,90	Mod. SP 35 Cod. 04AC118 €199,90	Mod. SP 35 Cod. 04AC120 €265,70
Mod. SP 70 Cod. 04AC102 €207,50	Mod. SP 70 Cod. 04AC119 €207,50	Mod. SP 70 Cod. 04AC121 €303,50
Mod. SP 110 Cod. 04AC122 €280,80		Mod. SP 110 Cod. 04AC128 €331,40
Mod. SP 235 Cod. 04AC124 €474,30		Mod. SP 235 Cod. 04AC130 €368,10
TERMOSTATO AMBIENTE +5/+30°C CON CAVO L=10 m SENZA SPINA ROOM THERMOSTAT +5/+30°C CABLE 10 m WITHOUT PLUG	TERMOSTATO ELETTRONICO DI PRECISIONE IP55 CON DISPLAY -10/+70°C SENZA CAVO E SPINA ELECTRONIC THERMOSTAT IP55 WITH DISPLAY -10/+70°C WITHOUT POWER CORD AND PLUG	PASSAPARETE SNORKEL + GUAINA FLESSIBILE SNORKEL PASS PLATE + FLEXIBLE DUCT
		
Cod. 02AC581 €49,30	Cod. 02AC294 €186,40	Mod. SP 35-70-110 (Ø 100 mm) Cod. 02AC793 €87,90 Mod. Guaina /Duct (Ø 100 mm, l= 5m) SP 35-70-110 (RIELLO-ECOFLAM) SP 235 (ECOFLAM) Cod. 02AC577 €140,40 Mod. SP 235 (Ø 150 mm) Cod. 02AC794 €95,60 Mod. Guaina /Duct (Ø 150 mm, l=5m) SP 235 (RIELLO) Cod. 02AC792 €163,40
ADATTATORE USCITA ARIA OUTLET ADAPTER	RACCORDO 1 VIA ONE WAY ADAPTER	RACCORDO 2 VIE TWO WAYS ADAPTER
		
Mod. SP 35 Cod. 04AC107 €161,90	Mod. SP 35 (Ø 450 mm) Cod. 02AC821** €182,20	Mod. SP 35 (Ø 400 mm) Cod. 02AC822** €203,10
Mod. SP 70 Cod. 04AC108 €179,60	Mod. SP 70 (Ø 500 mm) Cod. 02AC831** €195,80	Mod. SP 70 (Ø 400 mm) Cod. 02AC832** €224,70
Mod. SP 110 Cod. 04AC125 €230,20	Mod. SP 110 (Ø 600 mm) Cod. 02AC871** €216,30	Mod. SP 110 (Ø 500 mm) Cod. 02AC872** €249,90
Mod. SP 235 Cod. 04AC127 €377,00	Mod. SP 235 (Ø 700 mm) Cod. 02AC891** €268,00	Mod. SP 235 (Ø 600 mm) Cod. 02AC892** €314,90

\*\* Necessario abbinamento a "adattatore uscita aria" - Additionally it's necessary to buy "outlet adapter"

# SP - GENERATORI D'ARIA CALDA FISSI INDUSTRIALI A COMBUSTIONE INDIRECTA

KIT SERRANDA TAGLIAFUOCO MANDATA ARIA (REI 120) AIR OUTLET SHUTTER KIT (REI 120)	RACCORDO ASPIRAZIONE AIR INLET ADAPTER	GUAINA RINFORZATA PER RIPRESA ARIA REINFORCED FLEXIBLE AIR INLET DUCT
		
<b>Mod. SP 35</b> <b>Cod. 02AC828**</b> €767,50	<b>Mod. SP 35 (Ø 505 mm)</b> <b>Cod. 04AC112</b> €94,80	<b>Mod. SP 35 (Ø 510 mm, l=6m)</b> <b>Cod. 02AC795</b> €447,90
<b>Mod. SP 70</b> <b>Cod. 02AC838**</b> €806,30	<b>Mod. SP 70 (Ø 565 mm)</b> <b>Cod. 04AC113</b> €97,40	<b>Mod. SP 70 (Ø 570 mm, l=6m)</b> <b>Cod. 02AC796</b> €550,70
<b>Mod. SP 110</b> <b>Cod. 02AC878**</b> €851,00	<b>Mod. SP 110 (Ø 645 mm)</b> <b>Cod. 02AC874</b> €227,70	<b>Mod. SP 110 (Ø 650 mm, l=6m)</b> <b>Cod. 02AC797</b> €751,80
<b>Mod. SP 235</b> <b>Cod. 02AC898**</b> €929,70	<b>Mod. SP 235 (Ø 745 mm)</b> <b>Cod. 02AC894</b> €299,80	<b>Mod. SP 235 (Ø 750 mm, l=6m)</b> <b>Cod. 02AC804</b> €1.273,50
<b>KIT SERRANDA TAGLIAFUOCO INGRESSO ARIA (REI 120) AIR INLET FIRE SHUTTER KIT (REI 120)</b>	<b>FILTRO GAS GAS FILTER (P.in MAX 2 bar)</b>	<b>FILTRO REGOLATORE GAS GAS FILTER REGULATOR (P.in MAX 2 bar)</b>
		
<b>Mod. SP 35 (Ø 505 mm)</b> <b>Cod. 02AC908*</b> €889,80	<b>Mod. SP 35-70-110 (DN 25 - 1")</b> <b>Cod. 03AC603</b> €53,40	<b>Mod. SP 35/70/110 GAS METANO - NATURAL GAS (DN 25 3/4" or 1") (P.out set. 20mbar)</b> <b>Cod. 03AC617</b> €158,60
<b>Mod. SP 70 (Ø 565 mm)</b> <b>Cod. 02AC909*</b> €900,70		<b>Mod. SP 35/70/110 GPL - LPG (DN 25 3/4" or 1") (P.out set. 30mbar)</b> <b>Cod. 03AC618</b> €158,60
<b>Mod. SP 110 (Ø 645 mm)</b> <b>Cod. 02AC910*</b> €1.041,10	<b>Mod. SP 235 (DN 32 - 1 1/4")</b> <b>Cod. 03AC604</b> €103,70	<b>Mod. SP235 (DN 32 - 1 1/4") (P.out non settato - to be set)</b> <b>Cod. 03AC602</b> €364,30
<b>Mod. SP 235 (Ø 745 mm)</b> <b>Cod. 02AC913*</b> €1.248,10		
<b>TUBO GAS MEDIA PRESSIONE (l = 3 m) + VALVO- LA CHIUSURA + RACCORDI COLLEGAMENTO MEDIUM PRESSURE GAS HOSE (l = 3 m) + GAS VALVE + CONNECTIONS (P. MAX 10 bar)</b>	<b>TUBO GAS BASSA PRESSIONE (l = 2 m) + VALVOLA CHIUSURA + RACCORDI COLLEGAMENTO LOW PRESSURE GAS HOSE (l = 2 m) + GAS VALVE + CONNECTIONS (P.in MAX 0,5 bar)</b>	<b>TUBO SCARICO FUMI INOX L = 1 m STAINLESS STEEL EXHAUST PIPE L = 1 m</b>
		
<b>Mod. SP 35 - 70 - 110 Tubo/Hose gas 1"</b> <b>Cod. 03AC615</b> €423,70	<b>Mod. SP 35 - 70 - 110 Tubo/Hose gas 1"</b> <b>Cod. 03AC612</b> €256,70	<b>Mod. SP 35/70/110 (Ø 150 mm)</b> <b>Cod. 02AC285</b> €69,10
<b>Mod. SP 235 Tubo/Hose gas 1 1/4"</b> <b>Cod. 03AC616</b> €583,50		<b>Mod. SP 235 (Ø 200 mm)</b> <b>Cod. 02AC287</b> €83,60

\* Necessario abbinamento a "raccordo aspirazione" - Additionally it's necessary to buy "air inlet adapter"

\*\* Necessario abbinamento a "adattatore uscita aria" - Additionally it's necessary to buy "outlet adapter"



CURVA A 90° SCARICO FUMI IN INOX STAINLESS STEEL EXHAUST ELBOW		TERMINALE PER CAMINO IN INOX STAINLESS STEEL CHIMNEY POT	
			
Mod. SP 35/70/110 (Ø 150 mm) Cod. 02AC288	€57,20	Mod. SP 35/70/110 (Ø 150 mm) Cod. 02AC657	€54,60
Mod. SP 235 (Ø 200 mm) Cod. 02AC290	€64,30	Mod. SP 235 (Ø 200 mm) Cod. 02AC658	€59,80

Quadro elettrico - electrical panel



Legenda

- 1 Spia bruciatore
- 2 Spia surriscaldamento motore
- 3 Spia surriscaldamento termostati (overheating limit)
- 4 Spia alimentazione elettrica
- 5 Interruttore 4 posizioni:  
**O**= STOP  
**V**= VENTILAZIONE (ARIA FRESCA)  
**H**= RISCALDAMENTO  
**H+V**= RISCALDAMENTO CON VENTILAZIONE CONTINUA
- 6 Presa termostato ambiente/umidostato/timer

Legend

- 1 Burner power indicator light
- 2 Motor overheating indicator light
- 3 Thermostat overheating indicator light (overheating)
- 4 Electric power indicator light
- 5 Switch 4 positions:  
**O**= STOP  
**V**= VENTILATION (FRESH AIR)  
**H**= HEATING  
**H+V**= HEATING WITH CONTINUOUS VENTILATION
- 6 Socket for thermostat ambient/humidistat/timer

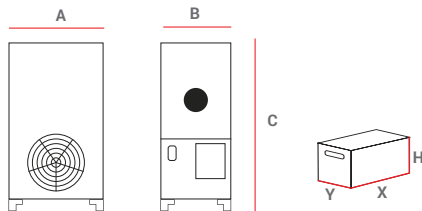

MOD	PESI E DIMENSIONI MACCHINA WEIGHTS AND DIMENSIONS MACHINE				IMBALLO PACKAGING			
	A	B	C	Netto/Net	X	Y	H	Lordo/Gross
	[mm]	[mm]	[mm]	[kg]	[mm]	[mm]	[mm]	[kg]
SP 35	724	511	1.308	102	1.270	785	660	122
SP 70	791	581	1.478	141	1.420	800	730	161
SP 110	1.092	646	1.678	225	1.150	700	1.750	255
SP 235	1.450	911	2.120	370	1.500	980	2.215	400





## SP - GENERATORI D'ARIA CALDA FISSI INDUSTRIALI A COMBUSTIONE INDIRECTA INDIRECT COMBUSTION INDUSTRIAL CABINET SPACE HEATERS



		SP 35 (OIL - GAS)	SP 70 (OIL - GAS)	SP 110 (OIL - GAS)	SP 235 (OIL - GAS)
codice - code		04SP101	04SP102	04SP103	04SP105
potenza term. nominale rated heat power	Hs [kW] Hs [kcal/h - BTU/h]	34,76 29.891-119.564	70,78 60.869-243.476	110,59 95.108-380.431	235,72 202.715-810.861
potenza term. resa output heat power	Hs [kW] Hs [kcal/h - BTU/h]	32,64 28.068-112.270	65,96 56.730-226.919	103,29 88.831-355.322	219,69 188.931-755.722
rendimento termico heat efficiency	[ % ]	93,90	93,20	93,40	93,40
portata d'aria air flow	[m <sup>3</sup> /h]	2.700	6.000	10.500	21.000
press. Statica disp available static press.	[Pa - mm H <sub>2</sub> O]	150-15	150-15	300-30	500-50
consumo gasolio fuel consumption	[kg/h]	2,75	5,60	8,75	18,65
consumo metano natural gas consumption G20	[m <sup>3</sup> /h]	3,25	6,45	10,275	21,854
pressione alimentazione inlet pressure G20	[mbar]	20	20	20	20
consumo GPL LPG consumption G31	[m <sup>3</sup> /h - kg/h]	1,298-2,53	2,58-5,03	4,006-7,97	8,527-16,77
pressione alimentazione inlet pressure G31	[mbar]	37	37	37	37
potenza elettrica power consumption 230V	[W]	680	1.350	2.590	5.100-5.160
alimentazione elettrica electrical power	[V - ph - Hz]	230-1-50	230-1-50	230-1-50	220/400-3-50
salto termico temperature rise	[°C]	43	49	35	35
<b>PREZZO - PRICE</b>	<b>EURO</b>	<b>2.828,00</b>	<b>3.761,00</b>	<b>5.084,00</b>	<b>7.071,00</b>

Valori ottenuti con bruciatori settati secondo le Normative ERP limiti 2018  
Technical data obtained with burners set according to the ERP regulations limit 2018

## BRUCIATORI A RICHIESTA / BURNERS ON DEMAND

BRUCIATORE GASOLIO ECOFLAM ECOFLAM DIESEL BURNER	BRUCIATORE GASOLIO RIELLO RIELLO DIESEL BURNER	BRUCIATORE RIELLO GPL + RAMPA GAS LPG RIELLO BURNER + GAS TRAIN
		
<b>Mod. SP 35 DIESEL/OIL</b> Cod. 072B116 <b>€781,00</b>	<b>Mod. SP 35 DIESEL/OIL</b> Cod. 076B106 <b>€781,00</b>	<b>Mod. SP 35 GPL/LPG</b> Cod. 074B111-14 <b>€1.837,00</b>
<b>Mod. SP 70 DIESEL/OIL</b> Cod. 072B117 <b>€879,00</b>	<b>Mod. SP 70 DIESEL/OIL</b> Cod. 076B107 <b>€879,00</b>	<b>Mod. SP 70 GPL/LPG</b> Cod. 074B101-14 <b>€1.837,00</b>
<b>Mod. SP 110 DIESEL/OIL</b> Cod. 072B112 <b>€968,00</b>	<b>Mod. SP 110 DIESEL/OIL</b> Cod. 076B102 <b>€968,00</b>	<b>Mod. SP 110 GPL/LPG</b> Cod. 074B103-04 <b>€2.276,00</b>
<b>Mod. SP 235 DIESEL/OIL</b> Cod. 072B115 <b>€1.274,00</b>	<b>Mod. SP 235 DIESEL/OIL</b> Cod. 076B105 <b>€1.274,00</b>	<b>Mod. SP 235 GPL/LPG</b> Cod. 074B105-08 <b>€2.893,00</b>
BRUCIATORE RIELLO METANO + RAMPA GAS NATURAL GAS RIELLO BURNER + GAS TRAIN		
		
<b>Mod. SP 35 METANO/NATURAL GAS</b> Cod. 074B112-14 <b>€1.837,00</b>		
<b>Mod. SP 70 METANO/NATURAL GAS</b> Cod. 074B102-14 <b>€1.837,00</b>		
<b>Mod. SP 110 METANO/NATURAL GAS</b> Cod. 074B104-04 <b>€2.276,00</b>		
<b>Mod. SP 235 METANO/NATURAL GAS</b> Cod. 074B106-08 <b>€2.893,00</b>		

# SP - GENERATORI D'ARIA CALDA FISSI INDUSTRIALI A COMBUSTIONE INDIRECTA INDIRECT COMBUSTION INDUSTRIAL CABINET SPACE HEATERS





VALORI COMUNI GAS-GASOLIO COMMON OIL-GAS DATA		SP 35 (OIL-GAS)	SP 70 (OIL-GAS)	SP 110 (OIL-GAS)	SP 235 (OIL-GAS)
codice - code		04SP101	04SP102	04SP103	04SP105
portata d'aria air flow	[m <sup>3</sup> /h]	2.700	6.000	10.500	21.000
press. Statica disp available static press.	[Pa - mm H <sub>2</sub> O]	150-15	150-15	300-30	500-50
potenza elettrica power consumption 230V	[W]	680	1.350	2.590	5.100-5.160
alimentazione elettrica electrical power	[V - ph - Hz]	230-1-50	230-1-50	230-1-50	220/400-3-50
salto termico temperature rise	[°C]	30	43	30	34
<b>PREZZO - PRICE</b>	<b>EURO</b>	<b>2.828,00</b>	<b>3.761,00</b>	<b>5.084,00</b>	<b>7.071,00</b>

VERSIONE GASOLIO OIL VERSION		SP 35 (OIL)	SP 70 (OIL)	SP 110 (OIL)	SP 235 (OIL)
potenza term. nominale rated heat power	Hs [kW] Hs [kcal/h - BTU/h]	25,91 22.282 - 89.129	59 50.760 - 203.041	95,40 82.042 - 326.529	198,35 170.585 - 678.928
potenza term. resa output heat power	Hs [kW] Hs [kcal/h - BTU/h]	24,31 20.906 - 83.623	55,21 47.481 - 189.925	89,66 77.109 - 306.895	185 159.177 - 633.527
rendimento termico heat efficiency	[%]	93,86	93,54	94	93,31
consumo gasolio fuel consumption	[kg/h]	2,05	4,67	7,55	15,70

VERSIONE GAS GAS VERSION		SP 35 (GAS)	SP 70 (GAS)	SP 110 (GAS)	SP 235 (GAS)
potenza term. nominale rated heat power	Hs [kW] Hs [kcal/h - BTU/h]	28,3 24.336 - 97.343	59,54 51.201 - 204.804	93,48 80.394 - 321.574	189,88 163.296 - 653.185
potenza term. resa output heat power	Hs [kW] Hs [kcal/h - BTU/h]	26,77 23.024 - 92.097	55,73 47.924 - 191.696	87,80 75.506 - 302.023	179,55 154.413 - 617.632
rendimento termico heat efficiency	[%]	94,6	93,6	93,92	94,56
consumo metano natural gas consumption G20	[m <sup>3</sup> /h]	2,6	5,487	8,597	17,364
pressione alimentazione inlet pressure G20	[mbar]	20	20	20	20
consumo GPL LPG consumption G31	[m <sup>3</sup> /h - kg/h]	0,993 - 2,04	2,111 - 4,21	3,398 - 6,79	6,869 - 13,89
pressione alimentazione inlet pressure G31	[mbar]	37	37	37	37

Valori ottenuti con bruciatori settati secondo le Normative ERP limiti 2021  
Technical data obtained with burners set according to the ERP regulations limit 2021

## BRUCIATORI A RICHIESTA / BURNERS ON DEMAND

BRUCIATORE GASOLIO ECOFLAM ECOFLAM DIESEL BURNER	BRUCIATORE RIELLO GPL + RAMPA GAS LPG RIELLO BURNER + GAS TRAIN	BRUCIATORE RIELLO METANO + RAMPA GAS NATURAL GAS RIELLO BURNER + GAS TRAIN
		
<b>Mod. SP 35 DIESEL/OIL</b> <b>Cod. 072B126</b> <b>€1.259,00</b>	<b>Mod. SP 35 GPL/LPG</b> <b>Cod. 074B111-14</b> <b>€1.837,00</b>	<b>Mod. SP 35 METANO/NATURAL GAS</b> <b>Cod. 074B112-14</b> <b>€1.837,00</b>
<b>Mod. SP 70 DIESEL/OIL</b> <b>Cod. 072B127</b> <b>€1.406,00</b>	<b>Mod. SP 70 GPL/LPG</b> <b>Cod. 074B101-14</b> <b>€1.837,00</b>	<b>Mod. SP 70 METANO/NATURAL GAS</b> <b>Cod. 074B102-14</b> <b>€1.837,00</b>
<b>Mod. SP 110 DIESEL/OIL</b> <b>Cod. 072B122</b> <b>€1.673,00</b>	<b>Mod. SP 110 GPL/LPG</b> <b>Cod. 074B103-04</b> <b>€2.276,00</b>	<b>Mod. SP 110 METANO/NATURAL GAS</b> <b>Cod. 074B104-04</b> <b>€2.276,00</b>
<b>Mod. SP 235 DIESEL/OIL</b> <b>Cod. 072B125</b> <b>€2.246,00</b>	<b>Mod. SP 235 GPL/LPG</b> <b>Cod. 074B105-08</b> <b>€2.893,00</b>	<b>Mod. SP 235 METANO/NATURAL GAS</b> <b>Cod. 074B106-08</b> <b>€2.893,00</b>

## ATTREZZATURE / EQUIPMENT



### SET PER PROVA BACHARACH

Permette di definire la quantità di ossido di carbonio presente nei fumi di combustione e di valutare l'eventuale necessità di taratura del bruciatore.

**Cod. 99AM001 €520,50**

### BACHARACH TEST SET

*Measures the quantity of black smoke residual present in exhaust fumes, suited for burner calibration.*



### ANALIZZATORE FUMI DI COMBUSTIONE

Preleva una piccola quantità di fumi dal camino al fine di misurarne la percentuale volumetrica di anidride carbonica.

**Cod. 99AM011 €6.564,70**

### COMBUSTION FUME ANALYSER

*Analyzes the gas exhaust fumes elements: CO, CO<sub>2</sub>, λ, smoke temperature, O<sub>2</sub>.*



### MANOMETRO

Consente la misurazione della pressione d'alimentazione del combustibile liquido.

**Cod. 99AM003 €42,00**

### MANOMETER

*Measures fuel pressure.*



### KIT MANOMETRO

Consente la misurazione della pressione di alimentazione del gas per generatori in media pressione (GA - GP)

**Cod. 99AM017.. €42,90**

### GAS PRESSURE GAUGE

*It allows the measurement of inlet gas pressure for medium pressure generators (GA, GP series)*



### MICROMANOMETRO GAS

Consente la misurazione della pressione d'alimentazione del gas.

**Cod. 99AM014 €547,20**

### GAS MICROMANOMETER

*It allows the measurement of the gas pressure.*



### CHIAVE PER UGELLO GASOLIO

Da utilizzarsi per la rimozione o la sostituzione dell'ugello gasolio sui bruciatori.

**Cod. 99AM004 €27,50**

### SPANNER WRENCH FOR OIL NOZZLE

*To remove or substitute the oil nozzle in the burners.*



### TERMOMETRO DIGITALE

Permette di rilevare la temperatura dei fumi e dell'aria.

**Cod. 99AM005 €547,20**

### DIGITAL THERMOMETER

*To measure the exhaust and air temperature.*



### IMBUTO DECANTATORE

Permette di separare l'acqua presente nel gasolio.

**Cod. 99AM018 €191,20**

### DECANTER

*Separates water present in the fuel.*

# PESI E DIMENSIONI / WEIGHTS AND DIMENSIONS

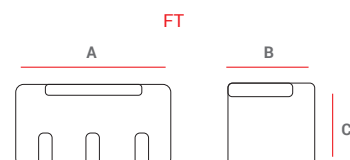
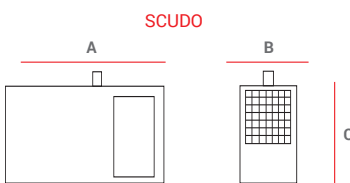
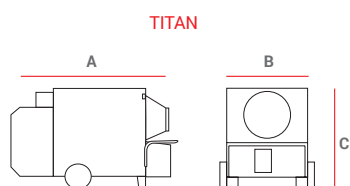
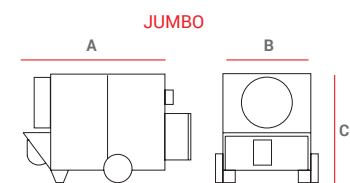
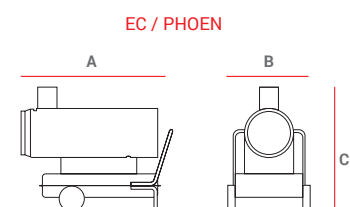
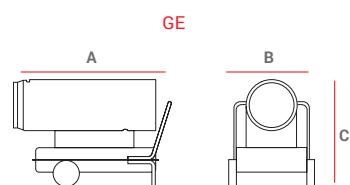
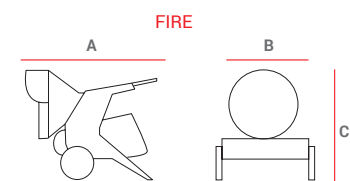
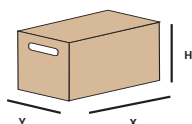

EDILIZIA ED EVENTI / CONSTRUCTION AND EVENTS													
MACCHINA - MACHINE				IMBALLO - PACKAGING				PALLET - PALLET					
MOD	A	B	C	Netto Net	X	Y	H	Lordo Gross	n°	X	Y	H	Lordo Gross
	[mm]	[mm]	[mm]	[kg]	[mm]	[mm]	[mm]	[kg]		[mm]	[mm]	[mm]	[kg]
FIRE 25	895	532	808	42	740	570	705	47	-	-	-	-	-
FIRE 45 1S	1.410	712	1.053	73	1.027	705	1.036	91	-	-	-	-	-
GE 20	720	300	450	20	760	320	425	23	20	1.300	800	2.320	472
GE 36	1.075	440	615	25	1.050	400	520	29	12	1.210	1.070	2.190	360
GE 46	1.075	440	630	38	1.050	400	580	45	9	1.210	1.070	1.870	417
GE 65	1.200	555	860	58	1.200	480	900	68	-	-	-	-	-
GE 105	1.492	670	1.005	86	1.690	620	1.050	111	-	-	-	-	-
EC 22	1.075	440	615	40	1.050	400	520	45	12	1.210	1.070	2.190	552
EC 32	1.215	440	670	48	1.175	400	605	55	6	1.200	800	1.960	342
EC 55	1.435	555	940	81	1.310	510	965	95	-	-	-	-	-
EC 85	1.740	690	1.025	110	1.690	620	1.050	135	-	-	-	-	-
PHOEN 110	1.918	731	1.220	149	1.870	660	1.210	174	-	-	-	-	-
JUMBO 85	1.648	770	1.133	172	1.600	680	1.135	192	-	-	-	-	-
JUMBO 110	1.765	800	1.214	200	1.775	710	1.240	220	-	-	-	-	-
JUMBO 145	1.905	890	1.354	254	1.870	780	1.330	274	-	-	-	-	-
JUMBO 185	2.013	912	1.414	270	1.980	800	1.390	290	-	-	-	-	-
JUMBO 235	2.245	982	1.584	351	2.220	880	1.560	371	-	-	-	-	-
TITAN 145	2.191	900	1.515	361	-	-	-	-	-	-	-	-	-
1/2	-	-	-	-	1.910	780	1.490	375	-	-	-	-	-
2/2	-	-	-	-	730	400	500	15	-	-	-	-	-
TITAN 185	2.413	920	1.620	430	-	-	-	-	-	-	-	-	-
1/2	-	-	-	-	2.140	800	1.595	435	-	-	-	-	-
2/2	-	-	-	-	760	400	500	15	-	-	-	-	-
TITAN 235	2.630	1.042	1.840	535	-	-	-	-	-	-	-	-	-
1/2	-	-	-	-	2.328	861	1.764	524	-	-	-	-	-
2/2	-	-	-	-	820	450	560	22	-	-	-	-	-
SCUDO 235	2.790	900	1.766	856	2.790	900	1.766	856	-	-	-	-	-
FT 230	600	800	600	27	600	800	600	27	-	-	-	-	-
FT 440	1.200	700	800	55,5	1.200	700	800	55,5	-	-	-	-	-
GP 10 M	367	180	280	5	392	277	217	6	72	1.200	800	2.110	444
GP 18 M	425	180	280	5,5	447	277	217	6,5	72	1.200	900	2.110	480

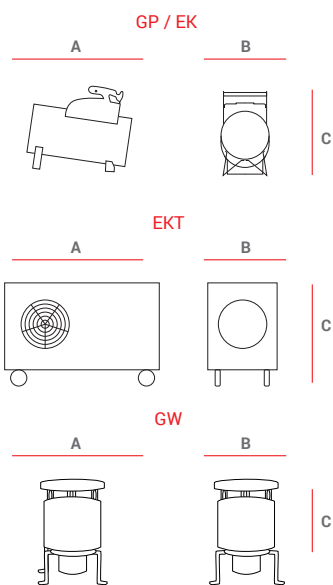

MACCHINA - MACHINE				IMBALLO - PACKAGING				PALLET - PALLET					
MOD	A	B	C	Netto Net	X	Y	H	Lordo Gross	n°	X	Y	H	Lordo Gross
	[mm]	[mm]	[mm]	[kg]	[mm]	[mm]	[mm]	[kg]		[mm]	[mm]	[mm]	[kg]
GP 30 M - A	505	277	511	10	542	387	315	11	36	1.200	1.080	2.030	408
GP 45 M - A	575	277	511	12	610	387	315	13	24	1.200	800	2.050	324
GP 65 M - A	580	317	538	14	632	432	350	15	24	1.260	1.000	2.230	372
GP 85 M - A	700	317	538	16	732	432	350	17	18	1.200	860	2.260	318
GP 105 M - A	835	438	606	26	845	460	470	29	12	1.300	1000	2.000	360
GW 32	528	528	676	17	450	450	700	18	12	1.000	1.000	2.220	225
EK 3 C	367	180	280	5	392	277	217	6	72	1.200	800	2.111	447
EK 10 C	505	277	511	13	542	387	315	14	36	1.200	1.084	2.056	533
EK 15 C	575	277	511	15	610	387	315	16	24	1.220	800	2.056	404,3
EK 22 C	700	317	538	21	732	432	350	22	18	1.200	864	2.200	411
EK 30 C	899	558	706	41	940	600	680	48	6	1.200	1.000	2.180	298
EK T	1.270	660	967	132	1.400	720	905	144	-	-	-	-	-

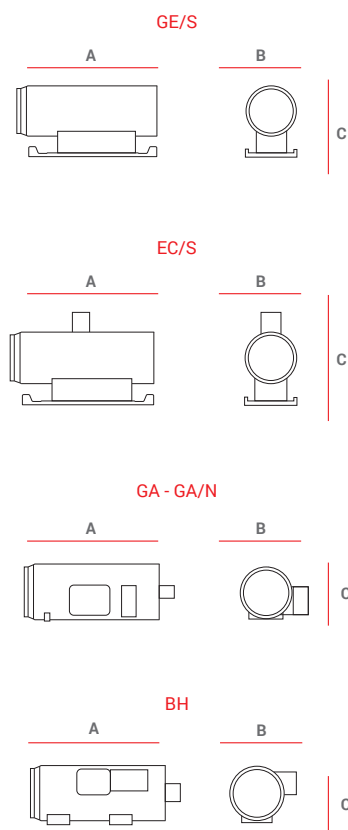
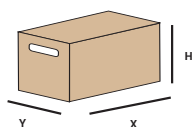

AGRICOLTURA E ALLEVAMENTO / AGRICULTURE AND BREEDING													
MACCHINA - MACHINE				IMBALLO - PACKAGING				PALLET - PALLET					
MOD	A	B	C	Netto Net	X	Y	H	Lordo Gross	n°	X	Y	H	Lordo Gross
	[mm]	[mm]	[mm]	[kg]	[mm]	[mm]	[mm]	[kg]		[mm]	[mm]	[mm]	[kg]
GE/S 65	1.200	480	550	44	1.310	510	790	64	-	-	-	-	-
GE/S 105	1.418	567	694	72	1.690	620	875	97	-	-	-	-	-
EC/S 55	1.400	480	605	67	1.310	510	800	80	-	-	-	-	-
EC/S 85	1.650	590	720	96	1.690	620	880	121	-	-	-	-	-
GE 125 AGRI	1.515	740	644	72	1.590	800	800	97	-	-	-	-	-
GA 100 C	1.146	589	441	36	1.190	605	490	41	8	1.200	1.200	2.060	360
GA/N 45 C	850	475	351	21	815	495	385	24	10	1.000	810	2.000	248
GA/N 70 C	1.146	596	441	46	1.190	660	624	61	-	-	-	-	-
GA/N 95 C	1.146	596	441	46	1.190	660	624	61	-	-	-	-	-
GA/N 115 C	1.200	689	530	56	1.240	750	718	74					
BH 50	1.379	670	630	75	1.430	750	718	100	-	-	-	-	-
BH 100	1.781	804	776	135	1.830	895	900	153	-	-	-	-	-
CH 100/135	1.718	851	963	190	1.890	880	1.110	210	-	-	-	-	-
1/2	-	-	-	-	1.870	1.890	1.110	210	-	-	-	-	-
2/2	-	-	-	-	1.030	930	370	15	-	-	-	-	-
FARM 85	980	910	738	99	-	-	-	-	-	-	-	-	-
1/3	-	-	-	-	1.020	920	740	104	-	-	-	-	-
2/3	-	-	-	-	500	500	320	17	-	-	-	-	-

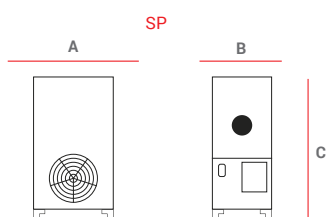
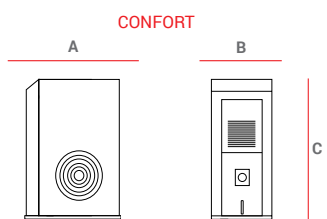
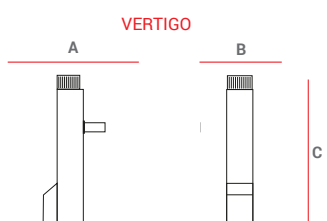
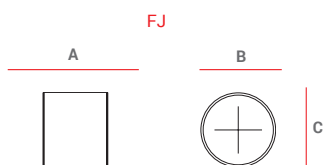
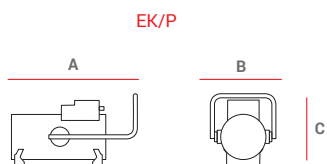
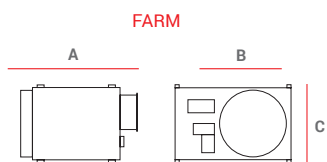
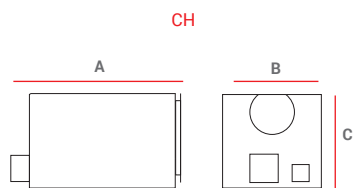

MACCHINA - MACHINE				IMBALLO - PACKAGING				PALLET - PALLET					
MOD	A	B	C	Netto Net	X	Y	H	Lordo Gross	n°	X	Y	H	Lordo Gross
	[mm]	[mm]	[mm]	[kg]	[mm]	[mm]	[mm]	[kg]		[mm]	[mm]	[mm]	[kg]
3/3	-	-	-	-	360	325	190	4,5	-	-	-	-	-
FARM 110	1.110	950	768	122	-	-	-	-	-	-	-	-	-
1/3	-	-	-	-	1.150	950	768	127	-	-	-	-	-
2/3	-	-	-	-	560	560	320	20	-	-	-	-	-
3/3	-	-	-	-	360	325	190	4,5	-	-	-	-	-
FARM 145	1.220	1.080	838	158	-	-	-	-	-	-	-	-	-
1/3	-	-	-	-	1.238	1.085	838	163	-	-	-	-	-
2/3	-	-	-	-	620	620	320	22	-	-	-	-	-
3/3	-	-	-	-	360	325	190	4,5	-	-	-	-	-
FARM 185	1.324	1.140	858	163	-	-	-	-	-	-	-	-	-
1/3	-	-	-	-	1.335	1.150	860	168	-	-	-	-	-
2/3	-	-	-	-	620	620	320	22	-	-	-	-	-
3/3	-	-	-	-	360	325	190	4,5	-	-	-	-	-
FARM 235	1.514	1.310	938	233	-	-	-	-	-	-	-	-	-
1/3	-	-	-	-	1.550	1.320	940	238	-	-	-	-	-
2/3	-	-	-	-	700	700	350	25	-	-	-	-	-
3/3	-	-	-	-	360	325	190	4,5	-	-	-	-	-
EK 15 P	768	450	445	20	632	432	350	21	24	1.264	1.000	2.200	519
FJ 18 M/T	430	489	486	14	500	500	460	15,5	16	1.000	1.000	2.000	255
FJ 22 M/T	439	570	567	18	590	590	460	19	14	1.200	1.000	2.000	275
FJ 25 T	480	652	650	20,5	670	670	530	22	4	670	670	2.270	95

INDUSTRIA / INDUSTRY													
MACCHINA - MACHINE				IMBALLO - PACKAGING				PALLET - PALLET					
MOD	A	B	C	Netto Net	X	Y	H	Lordo Gross	n°	X	Y	H	Lordo Gross
	[mm]	[mm]	[mm]	[kg]	[mm]	[mm]	[mm]	[kg]		[mm]	[mm]	[mm]	[kg]
VERTIGO 18	553	370	1996	67	2050	420	780	82	-	-	-	-	-
CONFORT 35	1.010	530	1.360	141	1.055	580	1.510	161	-	-	-	-	-
CONFORT 70	1.045	600	1.530	184	1.120	650	1.680	204	-	-	-	-	-
CONFORT 100	1.400	640	1.650	259	1.465	690	1.800	279	-	-	-	-	-
SP 35	724	511	1.308	102	1.270	785	660	122	-	-	-	-	-
SP 70	791	581	1.478	141	1.420	800	730	161	-	-	-	-	-
SP 110	1.092	646	1.678	225	1.150	700	1.750	255	-	-	-	-	-
SP 235	1.450	911	2.120	370	1.500	980	2.215	400	-	-	-	-	-

# FORMULE ED EQUIVALENZE / FORMULAS AND EQUIVALENCES

## CALCOLO DELLA POTENZA TERMICA / HEATING POWER CALCULATION

$$V \times \Delta T \times K = [\text{kcal/h}]$$

**V** = Volume ambiente: Lunghezza x Larghezza x Altezza (m<sup>3</sup>)  
*Volume: Length x Width x Height (m<sup>3</sup>).*

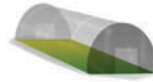

**ΔT** = Definisce in °C il divario tra la temperatura esterna e la temperatura interna che si vuole ottenere.  
*Is the difference between external temperature and required internal temperature.*



**K** = Coefficiente di dispersione del calore in base ai materiali impiegati nella costruzione.  
*Coefficient of loss heat according to the standard of insulation in your building.*



K = 0,6 - 0,9 Costruzione ben isolata: doppi muri, materiale isolante a soffitto, a parete e pavimenti, doppi vetri alle finestre e porte coibentate.  
*Good insulation: double wall, insulating ceiling material, insulating wall and floor material, double-glazed windows and insulated doors.*

K = 1,0 - 1,9 Costruzione discretamente isolata: doppi muri, materiale isolante a soffitto, poche finestre con vetri singoli.  
*Reasonable insulation: double wall, insulating ceiling material and few windows with single glasses.*

K = 2,0 - 2,9 Costruzione poco isolata: muri semplici con parti vetrate e tetto non coibentato.  
*Fair insulation: simple walls with glazed parts and non insulated roof.*

K = 3,0 - 4,0 Costruzione non isolata: coperture in legno, lamiera o materiale plastico.  
*Little or no insulation: wood covers, plate or plastic materials.*

Es. calcolo potenza termica - *Ex. of heating power calculation*

V = 20 m x 6 m x 4 m V = 480 m<sup>3</sup>    ΔT = -10°C T est., +24°C T int. ΔT = + 34°C    K = 4,0

480 m<sup>3</sup> x 34°C x 4,0 K = 65.280 [kcal/h]

## EQUIVALENZE - EQUIVALENCES

### Potenza Termica / Heating Power

1 kW = 860,61 kcal/h  
1 kW = 3415,18 BTU/h  
1 kcal/h = 3,97 BTU/h

### Pressione / Pressure

1 bar = 14,504 PSI  
1 bar = 10<sup>5</sup> Pa  
1 mm H<sub>2</sub>O = 9,806 Pa

### Consumo / Consumption

1 l/h = 0,2641 Gallon/h  
1 l/h = 0,22 Gallon (UK)/h  
1 m<sup>3</sup>/h = 35,31 CFh

### Temperatura / Temperature

°F = 9/5 x °C + 32  
°K = °C + 273,15

### Dimensioni / Dimensions

1 mm = 0,03937 Inches  
1 mm = 0,00328 Feet

### Superficie / Surface

1 m<sup>2</sup> = 1550,03 Inches<sup>2</sup>  
1 m<sup>2</sup> = 10,764 Feet<sup>2</sup>

### Capacità / Capacity

1 l = 0,2641 Gallon  
1 l = 0,22 Gallon (UK)

### Peso / Weight

1 kg = 35,274 Ounces  
1 kg = 2,205 Pounds

### Portata / Flow

1 m<sup>3</sup>/h = 0,5885 cfm



# CONDIZIONI GENERALI DI VENDITA

## TERMS OF SALE

Le presenti condizioni generali di vendita si applicano a tutti i contratti conclusi tra Biemmedue e i Clienti.

1. L'ordine sottoscritto dal Cliente vincola il medesimo; mentre Biemmedue si riserva la facoltà di non accettarlo, dandone comunicazione scritta al Cliente entro 3 giorni dal ricevimento. Il contratto di vendita si intende concluso con l'accettazione da parte di Biemmedue attraverso l'invio della c.d. conferma d'ordine.
2. Salvo diversa pattuizione scritta la vendita si intende effettuata ex-works Incoterms ICC 2010, cioè con consegna franco fabbrica, bordo camion.
3. Il termine di consegna indicato sull'ordine ha natura indicativa. Qualora Biemmedue non sia in grado di rispettarlo ne darà comunicazione scritta al Cliente con la conferma d'ordine ed in ogni caso tale termine non potrà mai essere per nessuna ragione considerato essenziale secondo quanto previsto dalla legge italiana.
4. Biemmedue ha facoltà di effettuare consegne parziali. Le condizioni di pagamento indicate sulla conferma d'ordine valgono anche per le consegne parziali.
5. La forma ed i termini di pagamento riportati sulla Conferma d'ordine emessa da Biemmedue sono vincolanti per il cliente.
6. I pagamenti devono essere effettuati secondo le condizioni indicate nella conferma d'ordine. I prezzi indicati nella conferma d'ordine sono al netto dell'IVA di legge e di eventuali spese per tasse o imposte che sono a carico del Cliente. In caso di ritardato pagamento decorreranno gli interessi di mora in misura pari all'Euribor a tre mesi in vigore al momento delle scadenze previste maggiorato di 5 punti. In caso di ritardato pagamento il contraente dovrà altresì rifondere a Biemmedue tutte le spese ed i danni originati dall'inadempienza.
7. Biemmedue si riserva la proprietà dei prodotti venduti sino all'integrale pagamento del prezzo da parte del Cliente. Ove la riserva di proprietà dovesse decadere attraverso la rivendita, l'unione con altri oggetti, ovvero la lavorazione, essa sarà rimpiazzata da una quota di proprietà del nuovo prodotto in ragione del valore del prodotto ovvero da una quota del medesimo valore, del credito derivante dalla rivendita, che il Cliente dichiara sin da ora di cedere a Biemmedue.
8. Qualora la conferma d'ordine preveda il pagamento in più rate del prezzo, ferma la riserva di proprietà della merce che rimarrà in capo a Biemmedue, il mancato pagamento da parte del Cliente anche di una sola rata non inferiore all'ottava parte del prezzo, provocherà l'immediata risoluzione del contratto e le rate pagate resteranno acquisite da Biemmedue a titolo di indennità, salvo il risarcimento del maggior danno. Resta inoltre espressamente inteso che, salvo autorizzazione scritta della Biemmedue, la merce sino all'integrale pagamento del prezzo dovrà rimanere presso il luogo di consegna.
9. Biemmedue garantisce la conformità dei prodotti forniti a quanto concordato. La garanzia per vizi è limitata ai difetti dei prodotti conseguenti a difetti di progettazione, di materiale o di costruzione, riconducibili a Biemmedue e non si applica nel caso in cui il compratore non provi di avere effettuato un corretto uso, manutenzione e conservazione del prodotto. La garanzia, salvo diversa pattuizione scritta, ha durata limitata a 12 mesi decorrenti dalla data di consegna. I reclami relativi a vizi e difetti di qualità ovvero non conformità che il compratore potrebbe rilevare non appena in possesso della merce, debbono essere effettuati dal Cliente, a pena di decadenza, non oltre 8 giorni dalla consegna. I vizi e difetti o non conformità occulti devono essere denunciati, a pena di decadenza, entro 8 giorni dalla scoperta e non oltre tre mesi dalla data di consegna della merce. I reclami devono essere effettuati mediante lettera raccomandata indirizzata a Biemmedue e devono indicare dettagliatamente i vizi e le difformità contestate. L'eventuale responsabilità di Biemmedue si intende limitata alla sola merce che si trova nello stato originale. In ogni caso Biemmedue non risponde per danni a cose e/o persone derivanti da uso improprio, installazione o da uso non conforme alle istruzioni e/o alle regole dell'arte, da cattiva manutenzione, da cause naturali ad essa non imputabili, da danneggiamento dovuto ad atti vandalici, a calamità naturali, ad atti di guerra, da uso di carburanti non idonei, uso di energia elettrica non conforme agli standard, manomissione, sabotaggio o comunque da difetti non imputabili a difetti di progettazione o fabbricazione del prodotto.
10. Eventuali resi saranno respinti se non preventivamente autorizzati per iscritto da Biemmedue. In ogni caso Biemmedue accetterà definitivamente il reso solo dopo verifica della merce restituita. Il reso deve essere accompagnato da packing list.
11. Il cliente non potrà proporre alcuna azione o eccezione se non avrà prima corrisposto integralmente il prezzo della merce acquistata e degli eventuali oneri accessori.
12. Salvo dolo o colpa grave di Biemmedue l'eventuale risarcimento del danno al compratore non potrà comunque superare il prezzo indicato nella fattura relativa ai prodotti contestati.
13. Tutti i rapporti tra le parti sono regolati secondo la legislazione italiana. Per eventuali controversie sarà esclusivamente competente il Foro di Torino.

*These Terms of Sale apply to all contracts of sale stipulated between Biemmedue and its Customers.*

1. *An order signed by the Customer is binding on same, but Biemmedue reserves the right to refuse an order by means of written notice to the Customer within 3 days after its receipt. The contract of sale is deemed stipulated when Biemmedue accepts it by means of its confirmation of order.*
2. *Unless expressly indicated otherwise in the order, goods are delivered ex works Incoterms ICC 2010, loaded on truck.*
3. *The delivery date specified on the order is approximate. If Biemmedue is unable to deliver by such date, it will inform the Customer in writing with the confirmation of order. Under no circumstances may such date be considered essential under Italian law.*
4. *Biemmedue has the right to make partial deliveries. The terms of payment specified on the confirmation of order also apply to partial deliveries.*
5. *The form and terms of payment specified on the Biemmedue's confirmation of order are binding on the Customer.*
6. *Payments must be made in conformity to the terms specified on the confirmation of order. The prices specified on the confirmation of order are net of VAT under law and of any taxes or duties to be paid by the Customer. In case of late payment, overdue interest will be charged at the 3-month EURIBOR rate in effect at the due dates plus 5 percentage points. In case of late payment, the Customer must also reimburse Biemmedue for all costs and damages deriving from the Customer's default.*
7. *Biemmedue reserves right of ownership of the sold equipment until the Customer has paid the price in full. If right of ownership should lapse due to resale, combination with other products, or reworking, it will be replaced by a share of ownership in the new product based on the value of such product or by a share of equal value of the credit deriving from the sale, which the Customer hereby declares that it will transfer to Biemmedue.*
8. *If the confirmation of order calls for payment of the price in multiple instalments, without prejudice to reservation of Biemmedue's ownership of the product, the Customer's failure to pay even a single instalment of not less than 1/8 (one eighth) of the price will immediately cancel the contract of sale and Biemmedue will retain any instalments paid as indemnity, without prejudice to compensation for greater damages. It is understood and agreed that the product will remain at the delivery site until full payment is made, unless otherwise authorised in writing by Biemmedue S.p.A.*
9. *Biemmedue guarantees that the supplied products conform to specifications. The warranty is limited to product defects due to design, material, or construction defects attributable to Biemmedue, and is not applicable if the Customer does not prove that it has used, serviced, and stored the product properly. Unless otherwise agreed in writing, the warranty has a term of 12 (twelve) months commencing on the delivery date. Complaints regarding any flaws, defects, or non-conformity that the Customer may detect when taking possession of the product must be made, under penalty of expiration, not later than 8 (eight) days after delivery. Latent flaws, defects, or non-conformities must be reported, under penalty of expiration, within 8 (eight) days of their discovery and not later than 3 (three) months after the delivery date. Complaints must be made by means of registered letter addressed to Biemmedue and must clearly specify the flaws and defects being contested. Any liability attributed to Biemmedue is limited to products in their original condition. Biemmedue will not be liable for personal injury or property damage deriving from improper use, installation or use not conforming to instructions and/or to best working standards, poor maintenance, natural causes not attributable to it, damage due to acts of vandalism, natural disasters, acts of war, use of inappropriate fuels, use of electrical energy not conforming to standards, tampering or sabotage, or from any other cause not attributable to design or manufacture defects.*
10. *Any returns will be refused unless previously authorised in writing by Biemmedue. Under all circumstances, Biemmedue will accept the return definitively only after inspecting the returned product. The return must be accompanied by the packing list.*
11. *The Customer may not bring any action or make any objection unless it has already paid in full the price of the product purchased and any ancillary costs.*
12. *Except in case of fraud or gross negligence by Biemmedue, any damages paid to the Customer may not exceed the price of the disputed product as specified on the invoice.*
13. *All relations between the parties are subject to Italian law. Any disputes will be subject to the exclusive jurisdiction of the Court of Turin, Italy.*

### Listino 397 GX 01/03/2022

I dati riportati nel presente catalogo non privano la ditta costruttrice del diritto di modificare, a proprio insindacabile giudizio, taluni particolari dei prodotti, in base alle proprie esigenze tecniche e di produzione. Il presente catalogo annulla e sostituisce le precedenti edizioni.

*The data given in this catalogue do not deprive the manufacturers of the right to modify some details of the products at their own unquestionable discretion, according to their technical and production needs. This catalogue annuls and replaces the previous ones.*

# BIEMMEDUE È ANCHE... *BIEMMEDUE IS ALSO...*

una gamma completa di  
**deumidificatori, idropultrici, spazzatrici, aspirapolvere,  
aspiraliquidi e monospazzole**  
per allevamento, agricoltura, industria, edilizia, casa.

*a complete range of  
dehumidifiers, high pressure cleaners, sweepers, wet and dry vacuum  
cleaners and single brush floor machines  
for livestock sheds, agriculture, industry, construction, leisure.*



## DOVE SIAMO - LOCATION

**Biemmedue S.p.A.**

**1. Sede legale - Headquarter:**

Via Industria, 12 - 12062 Cherasco CN  
T. +39 0172 486111 - F. +39 0172 488270

**2. Divisione pulizia - Cleaning division**

Via Fondovalle, 2 - 12062 Cherasco CN  
T. +39 0172 486111 - F. +39 0172 488270





Follow us on



[www.biemmedue.com](http://www.biemmedue.com)



BIEMMEDUE S.p.A. Via Industria, 12 - 12062 Cherasco (CN) - Italy - T. +39 0172 486111 - F. +39 0172 488270  
[bm2@biemmedue.com](mailto:bm2@biemmedue.com) - [www.biemmedue.com](http://www.biemmedue.com)